

O5K500

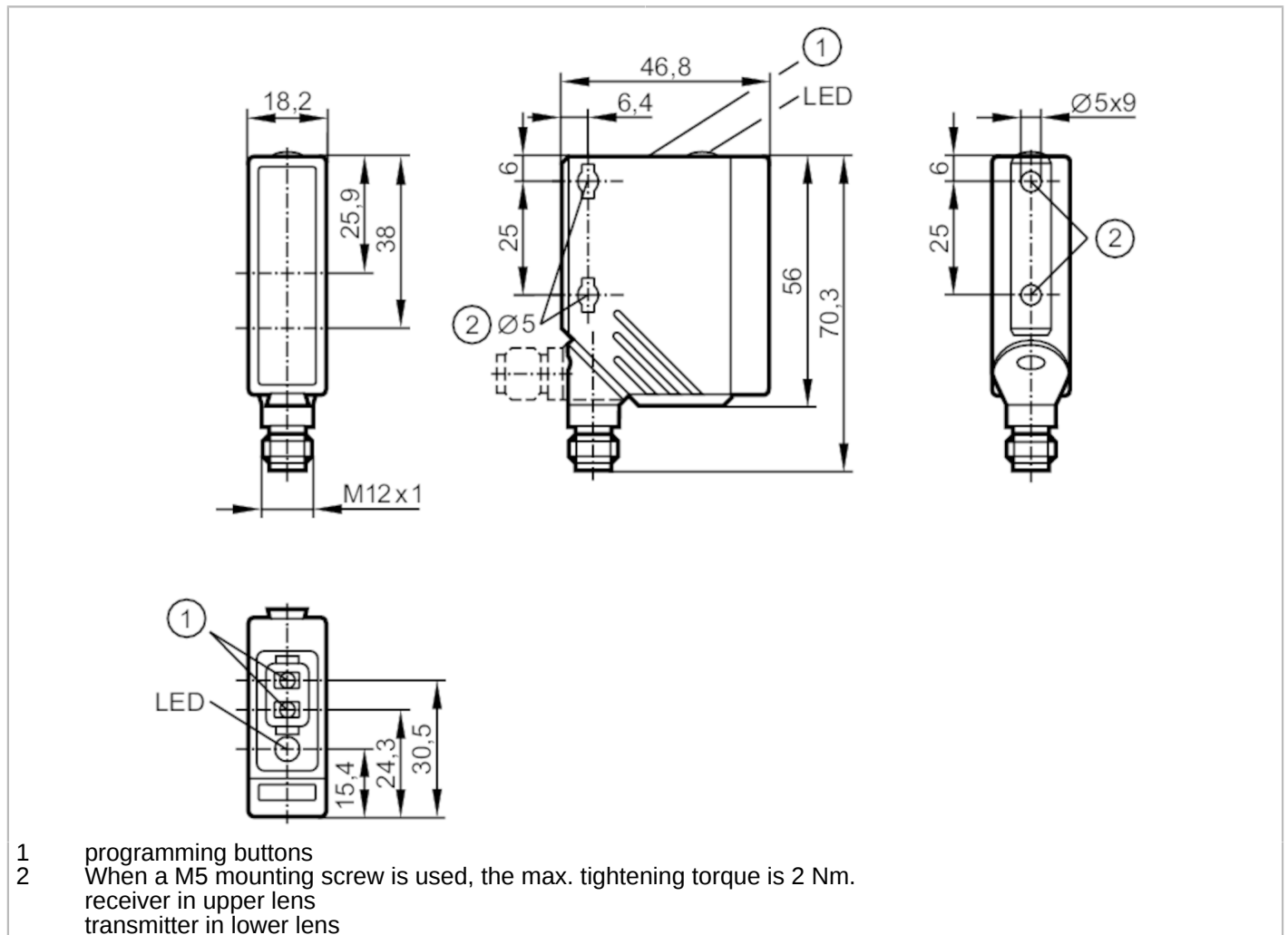

Contrast sensor

O5K-FAKG/US100



Product characteristics	
Type of light	red light; green light; blue light
Housing	rectangular
Dimensions [mm]	56 x 18.2 x 46.8
Electrical data	
Operating voltage [V]	10...36 DC
Current consumption [mA]	50; ((24 V))
Protection class	II
Reverse polarity protection	yes
Type of light	red light; green light; blue light
Wave length [nm]	625; 525; 465

O5K500



Contrast sensor

O5K-FAKG/US100

Outputs		
Electrical design	PNP/NPN; (automatic load detection PNP/NPN)	
Output function	light-on/dark-on mode; (programmable)	
Max. voltage drop switching output DC [V]	2.5	
Permanent current rating of switching output DC [mA]	200	
Switching frequency DC [Hz]	10000	
Short-circuit protection	yes	
Type of short-circuit protection	pulsed	
Overload protection	yes	
Detection zone		
Range [mm]	18...22	
Max. light spot width [mm]	1.5	
Max. light spot height [mm]	5	
Response times		
Response time [ms]	< 0.05	
Operating conditions		
Ambient temperature [°C]	-25...60	
Protection	IP 67	
Tests / approvals		
EMC	EN 60947-5-2	
MTTF [years]	568	
Mechanical data		
Weight [g]	79	
Housing	rectangular	
Dimensions [mm]	56 x 18.2 x 46.8	
Materials	housing: PA; bezel: stainless steel; operator interface: TPU / PC	
Lens material	front lens:PMMA	
Lens alignment	side lens	
Displays / operating elements		
Display	switching status	1 x LED, yellow
Teach function	yes	
Electronic lock	yes	
Remarks		
Remarks	operating voltage "supply class 2" according to cULus	
Pack quantity	1 pcs.	
Electrical connection		
Connector: 1 x M12		

O5K500



Contrast sensor

O5K-FAKG/US100

