

## Data Sheet

---

### DC 2.5mm panel jack solder screw

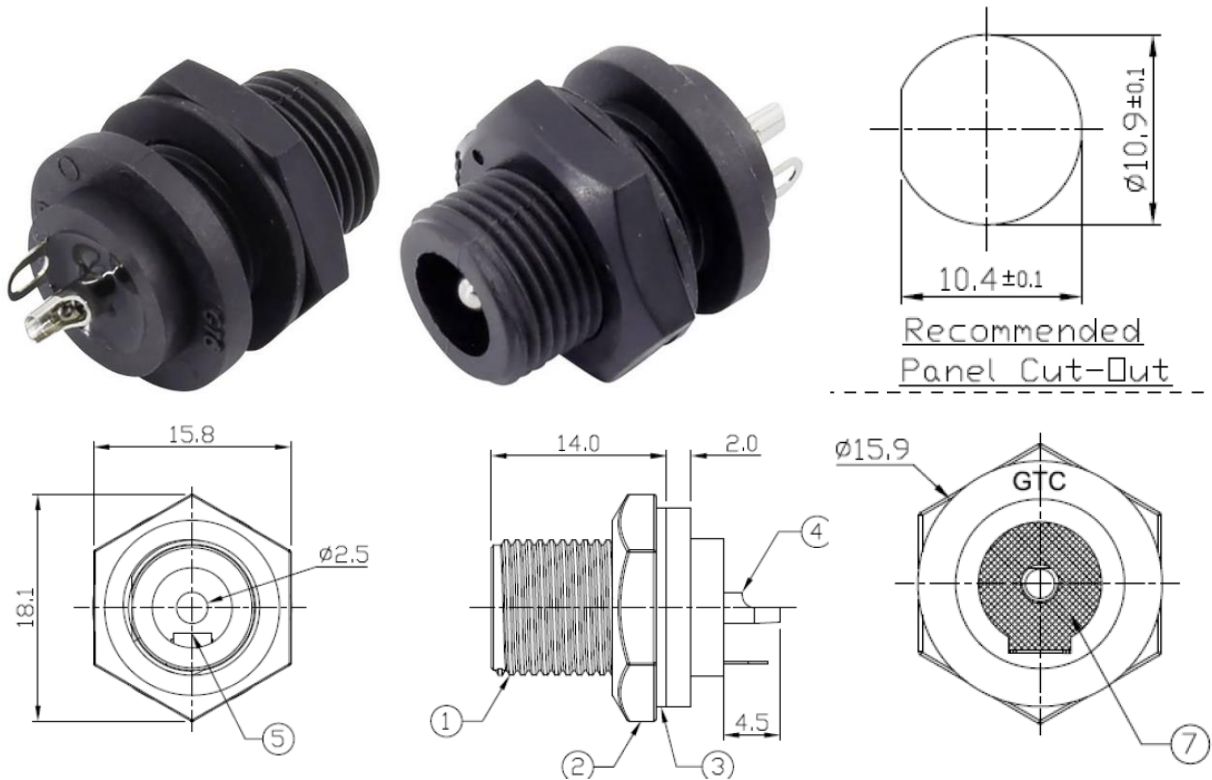

Outer-diameter of the suitable plug: 5.5mm

## Data Sheet

---

<b><u>PRODUCT SPECIFICATIONS</u></b>	
<b>Product Series</b>	<b>DC Jack/Plug Connector Size 1 Engineering Specifications</b>
Max Current Rating	7.0A
AWG Gauge	17 AWG –20 AWG
Environment Temperature	-40°C / +85°C
Max Power	65W
Input voltage	10V–32V
IP Rating	IPX7
<b>Material</b>	
DC Jack Housing/Hex Nut	PA66
DC Jack Contacts	Copper Alloy · Ni Plating
DC Jack Gasket	Silicone
Glue	Epoxy
DC Plug Housing/Screw Nut/Cover/Gland Nut	PA66
DC Plug O-Ring	Silicone
DC Plug	Insulation: PBT/ Contacts: Copper Alloy, Ni Plating

## Data Sheet

Technical Data	
Characteristics	Description
Visual and Dimensional Inspection	Must meet or exceed the requirements specified by the most current version of the DC Jack/Plug Specification.
Insulation Resistance	DC500V $\pm$ 10% , test for 1 minute and the insulation resistance should be more than100M $\Omega$
Dielectric Withstanding Voltage	500 V AC contact-to-contact, for 1min.
Contact Resistance	50m $\Omega$ at 10mA Max.
Pin Pull Test	1. Initial: 24 N minimum. 2. After Test: 16 N minimum.
Durability	2000 cycles insertion/extraction cycles at a maximum rate of 200 cycles per hour.
Insertion and withdrawal forces	Speed: 10 mm/s maximum. Insertion : 2500kgf maximum at a maximum rate of 6.9 mm per minute. Withdrawal : 1000kgf minimum at a maximum rate of 6.9 mm per minute.
Physical Shock	No discontinuities of 1 $\mu$ s or longer duration when mated DC Jack/Plug connectors are subjected to 11 ms duration 30 Gs half-sine shock pulses. Three shocks in each direction applied along three mutually perpendicular planes for a total of 18 shocks.
Random Vibration	The electrical load conditions shall be 100mA maximum for all contacts. Frequency: 50 to 2000 Hz PDS: 0.04 g <sup>2</sup> /Hz. Duration: 1 Hour/Axis, 3 Axes Total. g's: 7.56 g rms
Thermal Shock	5 cycles at -40°C / +105°C , after the test, the function and appearance can't be impacted.
Salt Spray	The test liquid (NaCl) thickness is 5%, Compressing the air pressure is 0.083Mpa, Spraying amount is 1~2 ml/80cm/h , Temperature of the pressure barrel is 43°C , LAB temperature is 35°C , relative humidity of LAB is 95%~98% , test time is 24hr , after the test, check if there is rusty and oxidized phenomenon
Waterproof Test	Under 1 M water for 30 min.
Temperature Life W/O Electrical Load	85°C for 96 Hours .
Low Temperature	-40°C for 96 Hours
Temperature Humidity Cycling	4 cycles at 25°C / +65°C 95%RH (1 cycles/day)
UV Exposure	24 H equal 1 year : 8 h UV at 70 ( $\pm$ 3) °C Black Panel Temperature 4 h Condensation at 50 ( $\pm$ 3) °C Black Panel Temperature