

- Rectangular, height 60 mm
- Active face in front
- Plastic, ABS
- Powered and operated only via BL ident interface module
- Male M12 x 1, only for use with BL ident extension cable

**Connectors .../S2503**

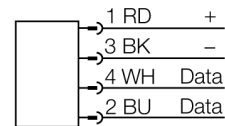

**.../S2500 Connectors**

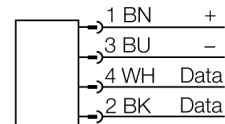

**.../S2501 Connectors**

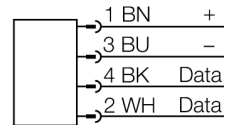

**Functional principle**

The UHF read/write heads form an air interface the size of which may vary, depending on the combination of read/write head and data carrier used.

The read/write distances mentioned here only represent standard values measured under laboratory conditions, free from any influences caused by surrounding materials.

Attainable distances may vary due to component tolerances, mounting conditions, ambient conditions and material qualities, especially when mounted in metal.

Testing of the application under real operating conditions is therefore essential, especially with read/write on-the-fly!

Because of the higher energy needs of the transponder on a write, the distance is reduced to approximately 40-60% of the reading range.

<b>Type designation</b>	TN902/915-Q120L130-H1147
Ident no.	7030670
<b>Mounting conditions</b>	non-flush
Ambient temperature	-20...+50 °C
<b>Operating voltage</b>	12... 24VDC
DC rated operational current	≤ 1000 mA
Data transfer	alternating electromagnetic field
Operating frequency	902...907.5 + 915...928 MHz
Radio communication and protocol standards	ISO 18000-6C EPCglobal Gen 2
Output power	≤ 0.5 W (ERP), adjustable
Antenna polarization	RHCP
Antenna HPBW	110°
Read/write distance max.	1500 mm
Output function	4-wire, read/write
<b>Construction</b>	rectangular
Dimensions	130x 120x 60mm
Housing material	Aluminium, AL, silver
Active area material	Plastic, ABS, black
<b>Electrical connection</b>	Flange connector, M12 x 1
Vibration resistance	55 Hz (1 mm)
Shock resistance	30 g (11 ms)
Protection class	IP67
Power-on indication	LED green
Diagnostic display	differently adjustable
<b>Packaged quantity</b>	1

Data carrier

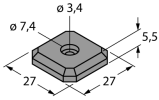
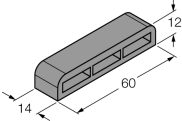
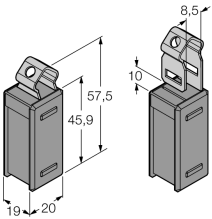
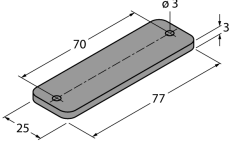
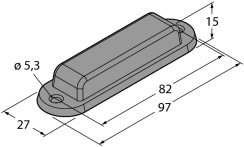
Dimensions	Type designation	Max. read distance [m]	
		air	On metal
	<b>TW902-928-Q27-M-B112</b> 7030406		
	<b>TW902-928-Q14L60-M-B110</b> 7030408		
	<b>TW865-928-Q20L58-B110</b> 7030375		
	<b>TW860-960-Q25L77-B-B112</b> 7030458		
	<b>TW860-960-Q27L97-M-B112</b> 7030464		

Data carrier

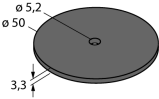
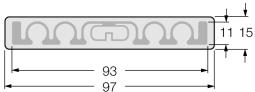
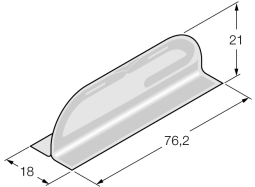
Dimensions	Type designation  Ident - no.	Max. read distance [m]	
		air	On metal
	<b>TW902-928-R50-B110</b> 7030404		
	<b>TW860-960-L97-15-F-B44</b> 7030524		
	<b>TW865-928-L76-18-21-F-M-B110</b> 7030380		