

MC21605G12W-VNMLY	2 x 16	5mm Character Height	VA Module
Specification			
Version: 1		Date: 29/09/2016	
Revision			

Display Features		
Character Count	2 x 16	
Appearance	Yellow on Black	
Logic Voltage	5V	
Interface	Parallel	
Font Set	English / Japanese	
Display Mode	Transmissive	
Character Height	5.55mm	
LC Type	VATN	
Module Size	80.00 x 36.00 x 13.20 mm	
Operating Temperature	-20°C ~ +70°C	
Construction	COB	
LED Backlight	Yellow	Weight / Display

* - For full design functionality, please use this specification in conjunction with the RW1063 specification. (Provided Separately)

Display Accessories	
Part Number	Description
MCCMDB-16SIL	LCD Interconnect board, can be driven from either a PC or a single Board computer with a USB output.
MCCBL1A16SLIP -16DILS-150	16 Way, Single in-line to Dual In-line connector Cable.
MCCBL1A16SLIP -16SILS-150	16 Way, Single in-line to Single In-line connector Cable.

Optional Variants		
Fonts	Appearances	Voltage
	Blue on Black Red on Black White on Black Green on Black	



Mechanical Specifications

Module Size	80.00 x 36.00 x 13.20 (With Backlight)				W x H x D mm
Viewing Area	66.00 x 16.00	W x H mm	Hole-to-Hole	71.20 x 31.00	W x H mm
Character Size	2.95 x 5.55	W x H mm	Character Pitch	3.55 x 5.95	W mm
Dot Size	0.55 x 0.65	W x H mm	Dot Pitch	0.60 x 0.70	W x H mm

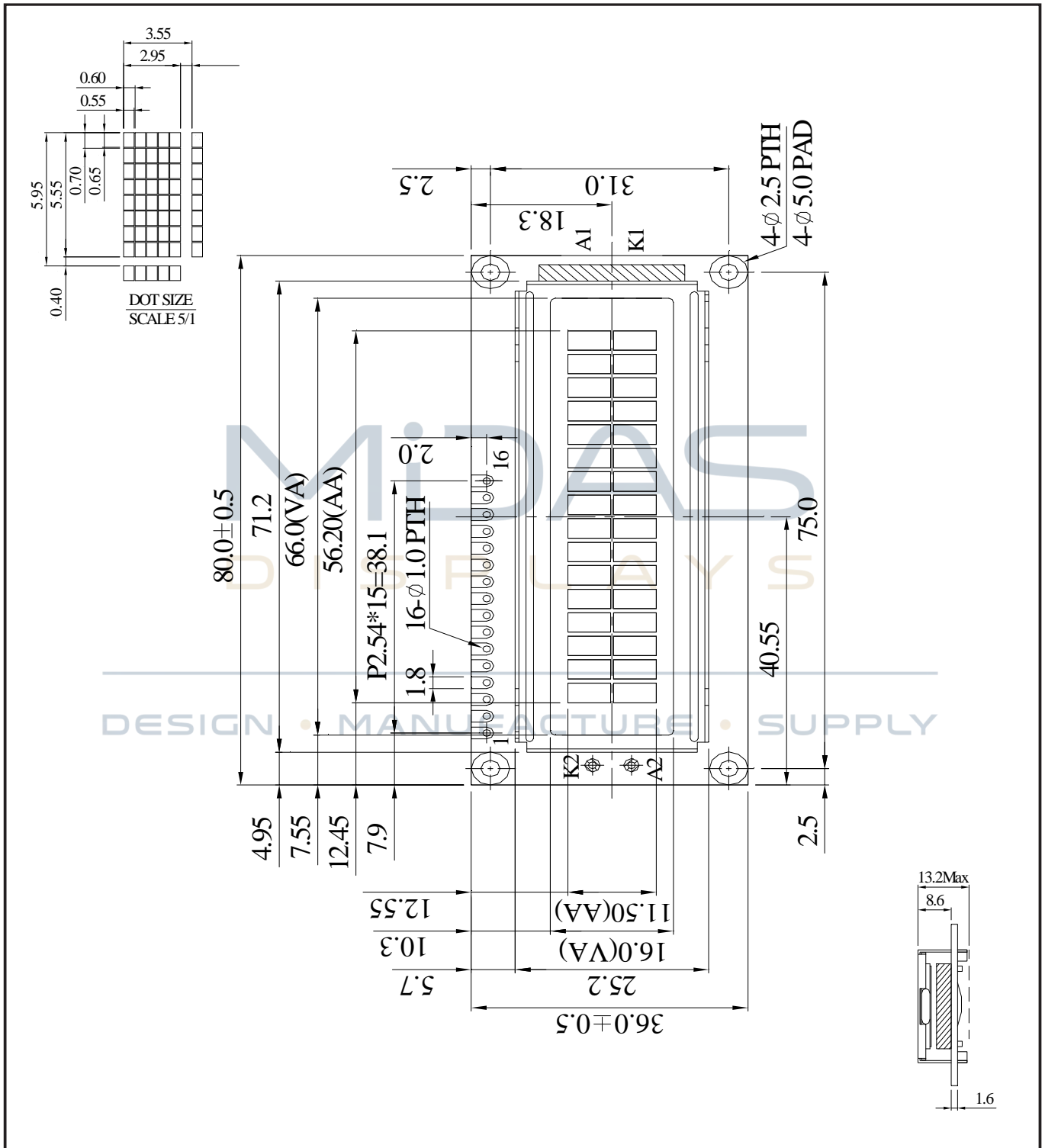

MC21605G12W-VNMLY	2 x 16	5mm Character Height	VA Module
Specification			
Version: 1		Date: 29/09/2016	
Revision			

Pin Layout

PI	SYMBOL	DESCRIPTION	REMARKS
1	Vss	GND	
2	Vdd	Power supply for LCM	5.0V
3	VO	Contrast Adjustment	
4	RS	Instruction Code	
5	R/W	Data Read / Write	
6	E	Chip Enable Signal	
7	DB0	Data bus line	
8	DB1	Data bus line	
9	DB2	Data bus line	
10	DB3	Data bus line	
11	DB4	Data bus line	
12	DB5	Data bus line	
13	DB6	Data bus line	
14	DB7	Data bus line	
15	Vee	Negative Voltage Output	
16	K	LED-	

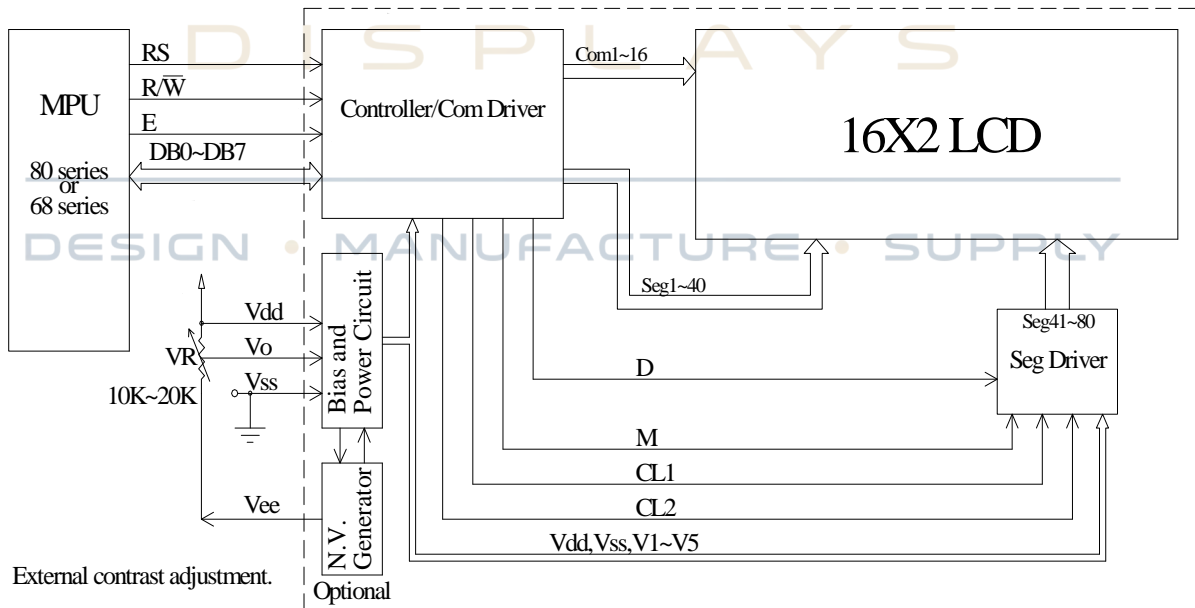

Character located	1	2	3	4	5	6	7	8	9	10	11	12	13	14	15	16
DDRAM address	00	01	02	03	04	05	06	07	08	09	0A	0B	0C	0D	0E	0F
DDRAM address	40	41	42	43	44	45	46	47	48	49	4A	4B	4C	4D	4E	4F

MC21605G12W-VNMLY	2 x 16	5mm Character Height	VA Module
Specification			
Version: 1		Date: 29/09/2016	
Revision			



Font Map

Upper 4bit Lower 4bit	LLLL	LLLH	LLHL	LLHH	LHLL	LHLH	LHHL	LHHH	HLLL	HLLH	HLHL	HLHH	HHLL	HHLH	HHHL	HHHH
LLLL	CG RAM (1)															
LLLH	(2)															
LLHL	(3)															
LLHH	(4)															
LHLL	(5)															
LHLH	(6)															
LHHL	(7)															
LHHH	(8)															
HLLL	(1)															
HLLH	(2)															
HLHL	(3)															
HLHH	(4)															
HHLL	(5)															
HHLH	(6)															
HHHL	(7)															
HHHH	(8)															

MC21605G12W-VNMLY	2 x 16	5mm Character Height	VA Module
Specification			
Version: 1		Date: 29/09/2016	
Revision			
Page 4 of 5			



Absolute Maximum Ratings

Item	Symbol	Condition	Min	Typ	Max	Unit
Power Supply (LOGIC)	Vdd	25 °C	-0.3	---	5.5	V
Power Supply (LCD)	V0	25 °C	Vss-0.3	---	Vss +7.0	V
Input Voltage	Vin	25 °C	-0.3	---	Vdd+0.3	V
Operating Temperature	Vopr	---	-20	---	70	°C
Storage Temperature	Vstg	---	-30	---	80	°C

Electronic Characteristics

Item	Symbol	Condition	Minimum	Typical	Maximum	Unit
Input Voltage High	V _{IH}	---	2.50	---	V _{DD}	V
Input Voltage Low	V _{IL}	---	-0.3	---	0.60	V
Output Voltage High	V _{OH}	---	3.90	---	Vdd	V
Output Voltage Low	V _{OL}	---	---	---	0.40	V
Supply Voltage Logic	V _{DD} ~ V _{SS}	---	4.50	5.00	5.50	V
Supply Voltage LCD	V _{DD} ~ V ₀	Ta=25°C	6.20	6.50	6.80	V
Supply Current	I _{DD}	V _{DD} =5.0V	---	2.00	---	mA

LCD Characteristics

For STN/FSTN LCD Panel Types						
Item	Symbol	Condition	Minimum	Typical	Maximum	Unit
Viewing Angle	Φ ₂ – Φ ₁	CR ≥ 10	---	60	---	ψ=180°
	Θ	---	---			
Contrast Ratio	CR	---	10	---	---	---
Response Time (Rise)	TR	---	---	300	350	ms
Response Time (Fall)	TF	---	---	300	350	ms

LED Characteristics

Item	Symbol	Condition	Minimum	Typical	Maximum	Unit
Supply Current	I _{LED}	V=5.0V	---	48	60	mA
Supply Voltage	V	---	4.90	5.00	5.10	V
Reverse Voltage	VR	---	---	---	5	V
Luminance (Without LCD)	IV	I _{LED} =48mA	1000	1250	---	Cd/m ²
Wave Length	λ _p	I _{LED} =48mA	565	570	575	---
LED Life Time	---	I _{LED} =48mA	---	50K	---	Hour

MC21605G12W-VNMLY	2 x 16	5mm Character Height	VA Module
Specification			
Version: 1		Date: 29/09/2016	
Revision			

