

Belt Tensioners SPANN-BOY® TS

Material: Housing made of steel, powder-coated black. Tensioning pulley made of ultra-high-molecular polyethylene based on PE-UHMW, electrostatically dissipative.

These very low, ready-to-install belt tensioners enable noise reduction and wear reduction at belts.

- With two springs of different strengths that can be activated individually or together. This allows three clamping forces to be set.
 - Usable tensioning way 40mm.
 - Max. permissible belt speed 6m/s.
- Temperature range: -20°C to +60°C.

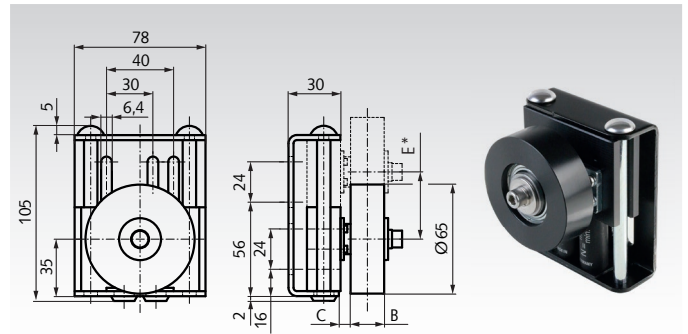

Ordering Details: e.g.: Product No. 140 418 01, Spann-Boy TS, B = 20mm

SPANN-BOY® TS

Product No.	B mm	C mm	E* mm	b** mm	Tension force N	Weight kg
140 418 01	20	13	40	15	33 - 190	0,62
140 418 02	30	8	40	25	33 - 190	0,64
140 418 03	40	8	40	35	33 - 190	0,67

* Tensioning way. ** Max. recommended belt width.

Adjustable Tensioning Forces:

The SPANN-BOY® TS has two different springs: one with low force and one with high force. These springs can get activated separately or together. So it is possible to adjust three different tensioning forces:

Only the low-force spring activated: 65 - 33 N.
 Only the high-force spring activated: 125 - 63 N.
 Both springs together activated: 190 - 96 N.

Belt Tensioners SPANN-BOX® Size 0

Material: Housing from thermoplast. Tensioning pulley made of ultra-high-molecular polyethylene based on PE-UHMW, electrostatically dissipative. Screws and spring from stainless steel.

These small, ready-to-install tensioners enable noise reduction and wear reduction at belts.

- With spiral, linear spring. On choice two tensioning forces.
 - With colored wear-off indicator: Green: o.k. Yellow: still o.k. Red: Tensioning force too low (below 32N or 60N).
 - Usable travel up to the end of the yellow range: About 32mm. Total travel about 40mm.
 - Max. permissible belt speed 3m/s
- Temperature range: -20°C to +60°C.

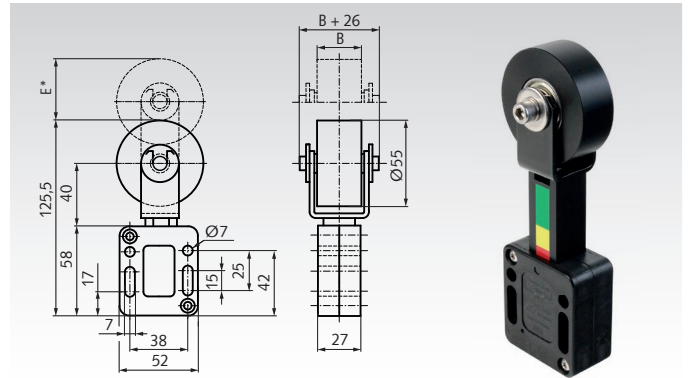

Ordering Details: e.g.: Product No. 140 411 01, Size 0, Low Tension Force, B = 20mm

SPANN-BOX® Size 0, Low Tensioning Force

Product No.	B mm	E* mm	b** mm	Tension force N	Weight kg
140 411 01	20	40	15	58 - 32	0,28
140 411 02	30	40	25	58 - 32	0,30
140 411 03	40	40	35	58 - 32	0,32

* Tensioning way. ** Max. recommended belt width.

SPANN-BOX® Size 0, High Tensioning Force

Product No.	B mm	E* mm	b** mm	Tension force N	Weight kg
140 412 01	20	40	15	132 - 60	0,28
140 412 02	30	40	25	132 - 60	0,30
140 412 03	40	40	35	132 - 60	0,32

Technical Note to Belt Tensioners SPANN-BOY® and SPANN-BOX®

Function: These tensioners are powered by linear spiral springs. The elastic tensioners are used to tension a belt with automatic compensation of the belt stretch. An application-related and optimally adjusted belt pre-tensioning force increases the service life as well as the functionality of the entire belt drive.

Determination of tensioning force: The tensioners SPANN-BOX® size 0 can be ordered with two different tensioning forces. At SPANN-BOX® size 1 and SPANN-BOY® TS, the tensioning force can get adjusted at different amounts.

Mounting: Mounting in the idle run is recommended. To enable a sufficient wrap angle, a belt wheel near the tensioner can be useful. All tensioners can be locked at maximum pretension for easy mounting. The locking device must then be released. In the case of the size 0 tensioning box, there is a small hole at the front and rear for a locking pin (supplied in the base of the housing).

Maintenance: The coloured wear indicator on all tensioners must be checked at regular intervals. The time interval depends on the conditions of use. If the red mark is visible, the clamping force is insufficient. Then the tensioner can be loosened, locked with maximum clamping force and readjusted. Slotted holes allow readjustment over a wide range. A check of the toothed belt and the tensioning pulley must be carried out before readjustment.

Operation manual at www.maedler.de