

DO NOT SCALE DRAWING

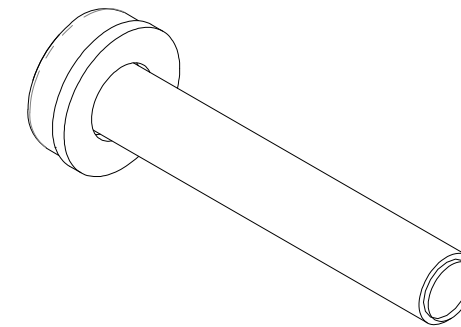
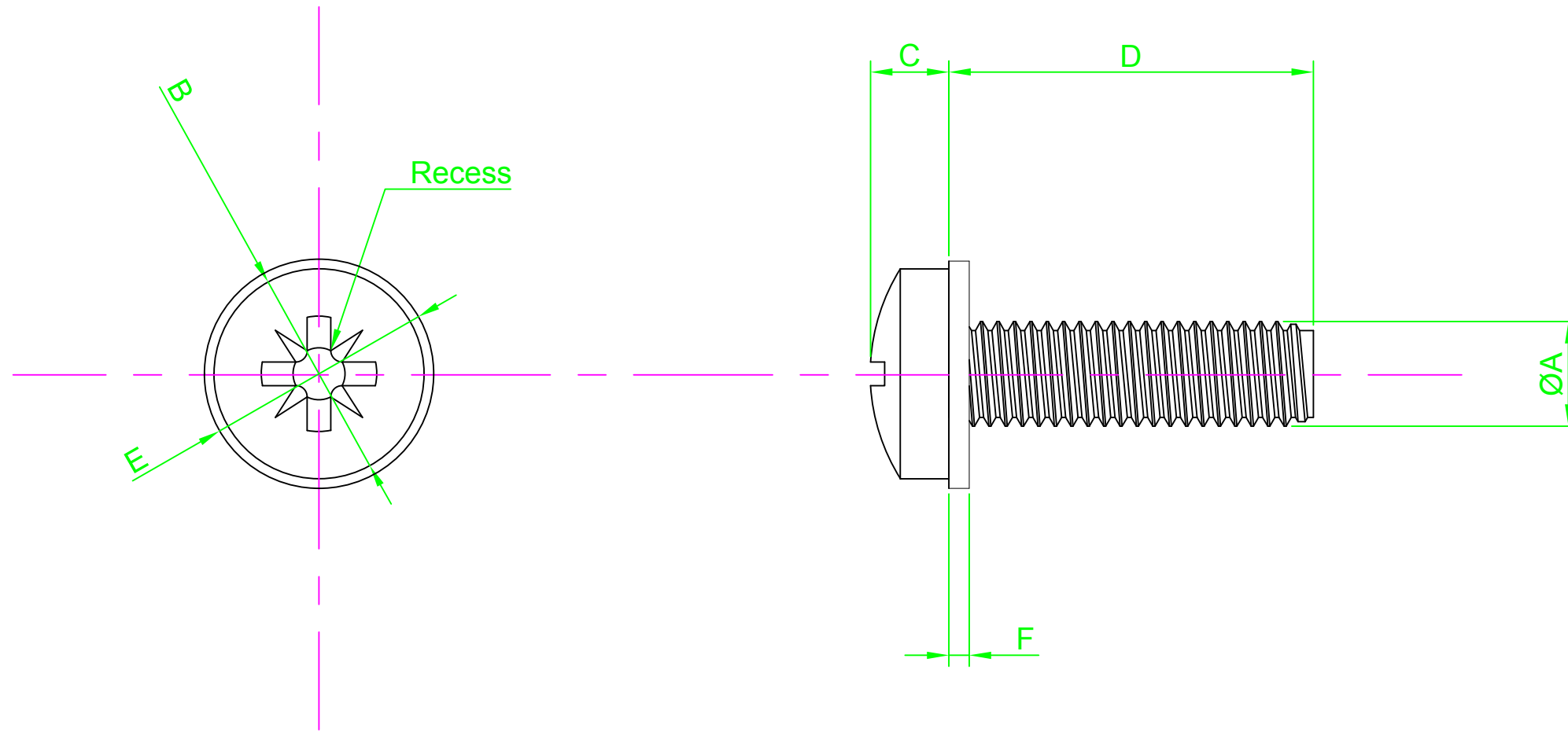

REVISION

A INITIAL DRAWING 23.9.15

PART NUMBER	ØA	ØB	C	D	E	F	RECESS
M3 6 PRSTPS Z100	M3-0.5	6.00 Max	2.1 Max	6mm	7.0 Max	0.5	POZI #1
M4 6 PRSTPS Z100	M4-0.7	8.00 Max	2.8 Max	6mm	9.0 Max	0.8	POZI #2
M4 12 PRSTPS Z100				12mm			

NOTES:
WASHER TO BE RETAINED BUT FREE TO ROTATE.



DESIGN RIGHT. TR FASTENINGS LTD. 2003
UNDER NO CIRCUMSTANCES MUST THIS
DRAWING BE COPIED OR DISCLOSED
WITHOUT FIRST OBTAINING WRITTEN
AUTHORITY.

UNLESS OTHERWISE SPECIFIED:
DIMENSIONS ARE IN MM (MILLIMETERS).
SURFACE FINISH:
TOLERANCES: DIN 7985 / 125

	NAME	DATE
DRAWN	Darryl Wilson	23.09.15
CHK'D		
APPVD		

CUSTOMER PART NUMBER:
N/A

MATERIAL:
STEEL

HEAT TREATMENT:

FINISH:
TC1 - Commercial Zinc/Clear Trivalent

TITLE:
Pozi Pan Head Machine Screw c/w Plain
SEMS Washer

DRAWING NUMBER:
TR32PRSTPS-Z100

A4

PROJECTION

