

COMMENT: ALL RIGHTS ARE RESERVED BY US FOR THIS DRAWING. WITHOUT OUR PRIOR CONSENT, IT MAY NEITHER BE DUPLICATED NOR MADE AVAILABLE TO A THIRD PARTY, AND IT ALSO MAY NOT BE IMPROPERLY USED BY THE RECEIVER, OR A THIRD PARTY.

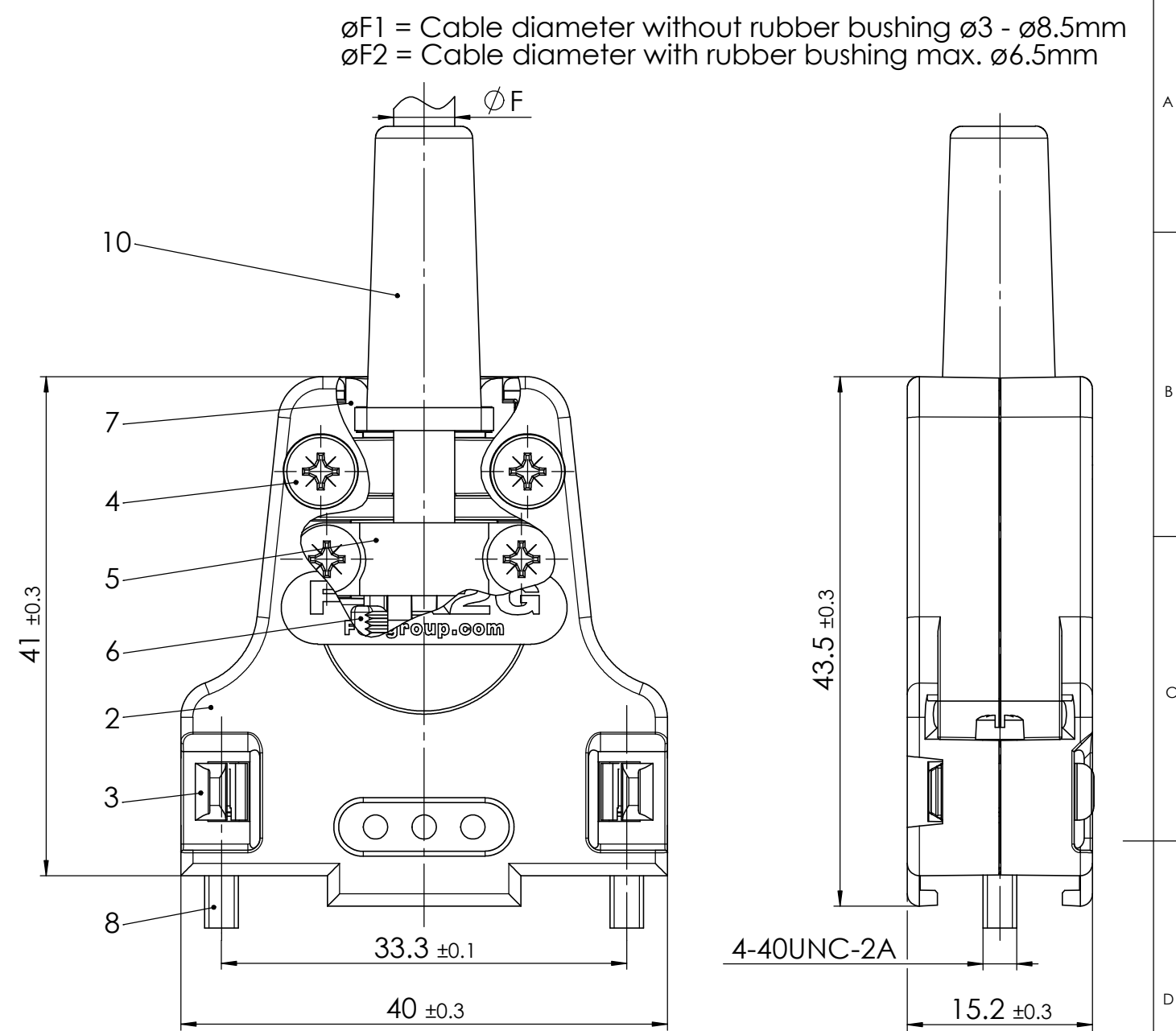

ØF1 = Cable diameter without rubber bushing ø3 - ø8.5mm  
 ØF2 = Cable diameter with rubber bushing max. ø6.5mm

11	3	High power contact	FMP003S103	20A / AWG 12-14
10	1	Rubber bushing	TPE	black
9	2	Locking screw	FVS1/5-K1163 M3 / Steel	nickel plated
8	2	Locking screw	FVS1/5-K1163 4-40 / Steel	nickel plated
7	2	Cable reduction plate	Zinc die-cast	nickel plated
6	1	Strain relief	ABS	nickel plated
5	1	Cable clamp	Steel	tin plated
4	4	Screw	Case hardened steel	zinc plated
3	2	Catch spring	PEI	black
2	1	Hood	FMK2G / Zinc die-cast	nickel plated
1	1	Mixed-Layout Connector	FM3W3S-K121	
No.	St.	Part	Type Description / Material	Surface plating / Colour / Class

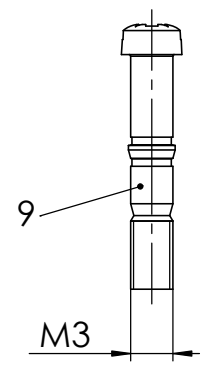
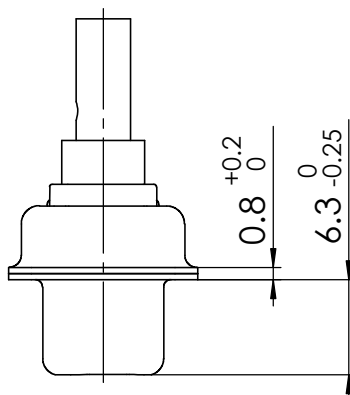
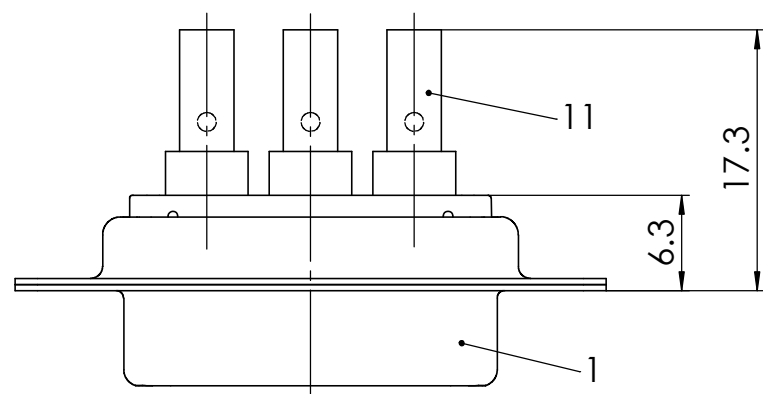
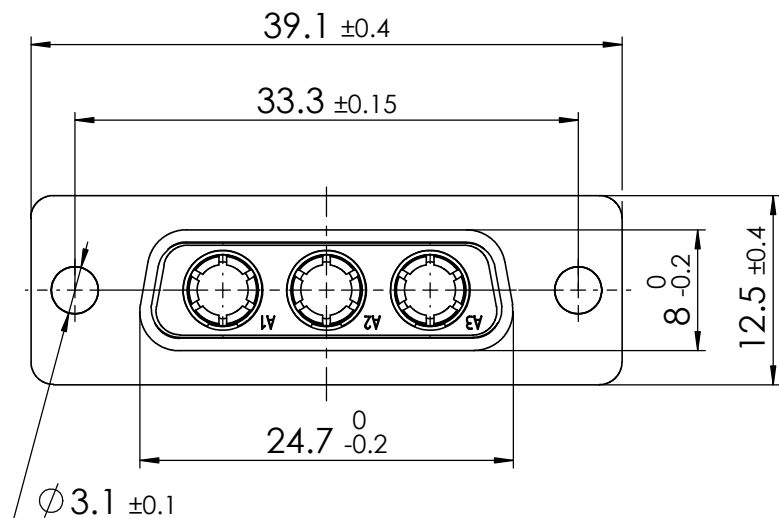
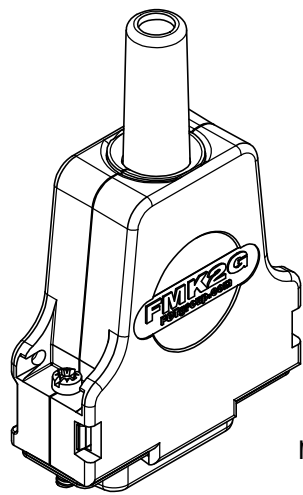

reverse side  
1:1

RoHS compliant  
by exemption

Packing unit on supplement AM0665

max. torque are 40 Ncm  
Part-No. 4, 5, 10 and 11 not mounted

SYMBOLS		THIS DRAWING CONTAINS INFORMATION THAT IS PROPRIETARY TO MOLEX ELECTRONIC TECHNOLOGIES, LLC AND SHOULD NOT BE USED WITHOUT WRITTEN PERMISSION			<b>molex</b>	
▽ = 0	▽ = 0	DIMENSION UNITS	SCALE	MEASUREMENTS WITHOUT TOLERANCE ACC. TO ISO 2768-m		
▽ = 0	▽ = 0	mm	2:1	CURRENT REVISION	FCT Hood Connector Set	
▽ = 0	▽ = 0			DRWN: DRAWN BY ameyerrichte 10-08-2021		
▽ = 0	▽ = 0			APPR: APPR BY BWittek 12-08-2021	PRODUCT CUSTOMER DRAWING	
▽ = 0	▽ = 0			INITIAL REVISION		
▽ = 0	▽ = 0			DRWN: DRAWN BY ameyerrichte 10-08-2021	MATERIAL NUMBER	REVISION
▽ = 0	▽ = 0	1		APPR: APPR BY BWittek 12-08-2021	1731140984	1
▽ = 0	▽ = 0	REV.	CH.-NO.		DOCUMENT NUMBER	CUSTOMER
▽ = 0	▽ = 0				FMK2G-3W3S-6195	GENERAL MARKET
▽ = 0	▽ = 0	REPLACEMENT FOR:	THIRD ANGLE PROJECTION	DRAWING		SHEET NUMBER
▽ = 0	▽ = 0			A3-SIZE		1 OF 1