

Crimp Terminal, Socket



FEATURES:

Vinyl fully-insulated
Double crimp
Funnel entry

SPECIFICATION:

Material	Brass
Insulation material	Vinyl
Surface material	Tin-plated
Temperature range	max. +105 °C

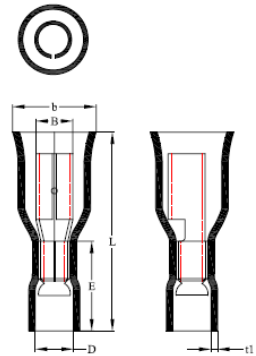

Article Nr.	AWG	Contact	Colour	D	B	L	t	b	E	t1
RND 465-00591	12-10 AWG	4 ... 6 mm ²	Yellow	6.5 mm	5.65 mm	25 mm	0.4 mm	7.8 mm	10.5 mm	0.8 mm
RND 465-00597	22-16 AWG	0.5...1.5 mm ²	Red	4.3 mm	4.65 mm	25 mm	0.4 mm	8.5 mm	13 mm	0.8 mm

Crimping Usage Instruction

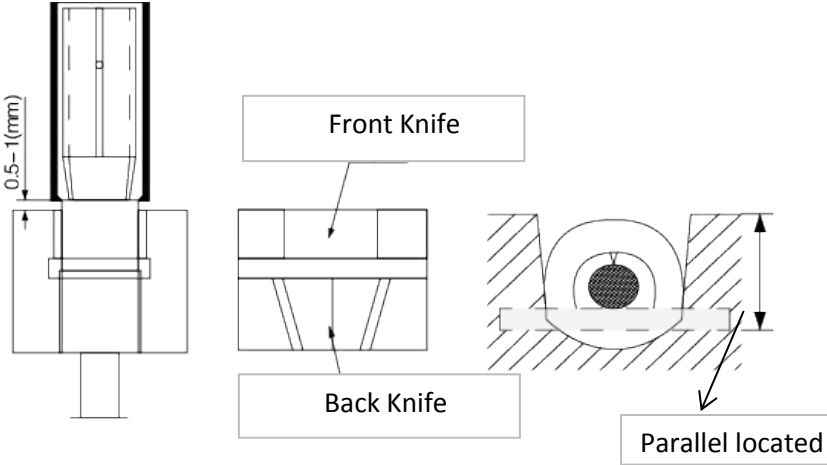
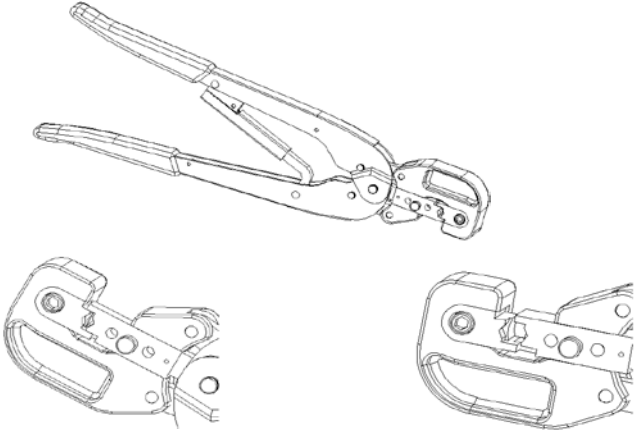
Product Category	5mm ²	<p style="text-align: center;">Crimping Position and Direction</p> 	
Wire Range	12-10(AWG)		
Stripping Wire Length	9.5mm		
Crimping Tool	#5		
<p style="text-align: center;">Crimping Tool</p> 		<p style="text-align: center;">Shape After Crimping</p> 