

- 1
- 2
- 3
- 4
- 5
- 6
- 7
- 8
- 9
- 10
- 11
- 12
- 13
- 14
- 15
- 16
- 17
- 18

MATERIAL

Transparent polyamide based (PA-T) technopolymer. High resistance to shocks, solvents, oils with additives, aliphatic and aromatic hydrocarbons, petrol, naphtha, phosphoric esters. Avoid contact with alcohol or detergents containing alcohol.

PROTECTION FRAME

Zinc-alloy, sandblasted and treated finish.

SCREWS, NUTS AND WASHERS

Zinc-plated steel.

PACKING RINGS

Step-shaped for the seal on the reservoir walls and NBR synthetic rubber O-ring screw underhead.

Suggested roughness of the packing ring application surface Ra = 3 µm.

CONTRAST SCREEN

White lacquered aluminium. The housing, in the appropriate external rear slot, guarantees the best protection from direct contact with fluid. It can be taken out from the inclined side, before assembly to allow the insertion of level lines or words.

STANDARD EXECUTIONS

- HCX-P: without thermometer.
- HCX/T-P: with incorporated thermometer.

MOUNTING

When fitting is not possible from the inside of the reservoir and the walls are not thick enough, the screws can be used together with Fast Mounting Kit (see page 1597)

MAXIMUM CONTINUOUS WORKING TEMPERATURE

90°C (with oil).

FEATURES AND PERFORMANCES

Ultrasound welding to guarantee a perfect seal. Lens effect for a better visibility of the fluid level and temperature. Special openings in the protection frame provide maximum fluid level visibility even from side positions. All shocks are absorbed by the frame that transmits them directly onto the wall of the reservoir.

TECHNICAL DATA

In laboratory tests carried out with mineral oil type CB68 (according to ISO 3498) at 23°C for a limited period of time, the weld stood up to 18 bar.

For use with other fluids and under different pressure and temperature conditions, please contact ELESA Technical Department.

In any case we suggest to verify the suitability of the product under the actual working conditions.

SPECIAL EXECUTIONS ON REQUEST

- Level indicators for use with fluids containing alcohol or with hot water.
- UV resistant transparent technopolymer indicators.
- Protection frame with indicators type HCX-SST (see page 1589), HCX-BW-SST (see page 1591), HCX-AR (see page 1590).
- Indicators with two red ball-shaped floats (only for the execution without thermometer).
- Indicators with cylindrical or step-shaped (NBR or FKM) packing rings (instead of OR) for mounting on reservoirs having rough surfaces or in any case not perfectly flat.



ELESA Original design

Drilling template
Holes without burrs and chamfer

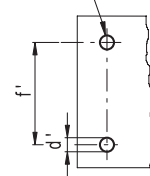

HCX-P

HCX/T-P

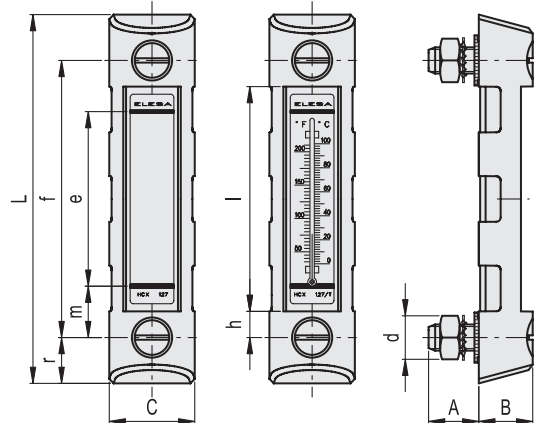

Code	Description	f	d	A	B	C	L	e	h	l	m	r	d ^{-0.2}	f ^{±0.2}	C# [Nm]	⚠
11371	HCX.127-P-M12	127	M12	22	25	39	169	80	12	103	23	21	12.5	127	12	279
11376	HCX.127/T-P-M12	127	M12	22	25	39	169	80	12	103	23	21	12.5	127	12	281