

**MATERIAL**

Glass-fibre reinforced polyamide based (PA) technopolymer, RAL 5001 blue colour, matte finish.

Produced from FDA compliant raw material (FDA CFR.21 and EU 10/2011). The special technopolymer contains additives detectable by means of metal detectors.

**STANDARD EXECUTION**

AISI 303 stainless steel bosses, threaded holes.

**FEATURES AND APPLICATIONS**

The RAL 5001 blue colour is easily visible in case of accidental food contamination. Furthermore the material additives are metal detectable at a cubic particle size of 5mm per side.

In order to improve the detection, the metal detector calibration must take into account the food/substance type at risk of contamination considering the moisture contained in it.

Particularly suitable for applications in the food and pharmaceutical industries.

**TECHNICAL DATA**

Tensile stress and impact strength: F1, F2, L1 and L2 values reported in the table are the result of breaking tests carried out with the appropriate dynamometric equipment under the test conditions shown in the figure with ambient temperature.



ELESA Original design

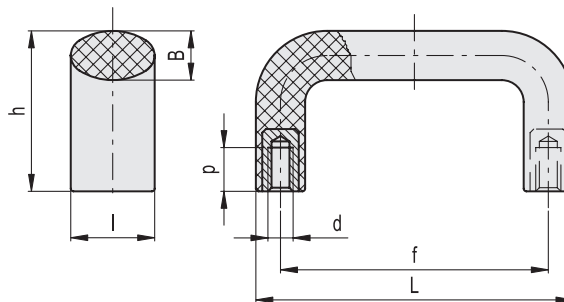
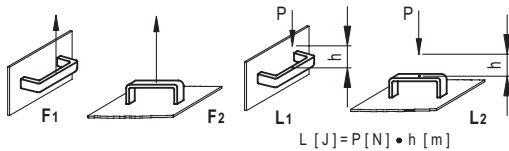

Code	Description	L	f	d6H	h	B	l	p	F1 [N]	F2 [N]	L1 [J]	L2 [J]	⚖️
199113	M.643/140-117-SST-M8-MD	134	117±0.5	M8	49	15	25	13	2500	4500	8	12	67
199153	M.643/200-SST-M8-MD	196	179±1	M8	57	16	27	13	2000	3000	11	15	130

- 1
- 2
- 3
- 4
- 5
- 6
- 7
- 8
- 9
- 10
- 11
- 12
- 13
- 14
- 15
- 16
- 17
- 18