

4G LTE-NA click (North America)

MIKROE-2535

Weight: 36 g



4G LTE-NA click carries the [LARA-R204](#) multi-mode cellular module from u-blox.

The board is designed to use 5V power supply. I/O voltage levels could be 3.3V or 5V. It communicates with the target microcontroller over UART interface, with additional functionality provided by the following pins on the mikroBUS™ line: AN, RST, CS, PWM, INT.

4G LTE-NA click carries the [LARA-R204](#) multi-mode cellular module from u-blox. The board is designed to use 5V power supply. I/O voltage levels could be 3.3V or 5V. It communicates with the target microcontroller over UART interface, with additional functionality provided by the following pins on the mikroBUS™ line: AN, RST, CS, PWM, INT.

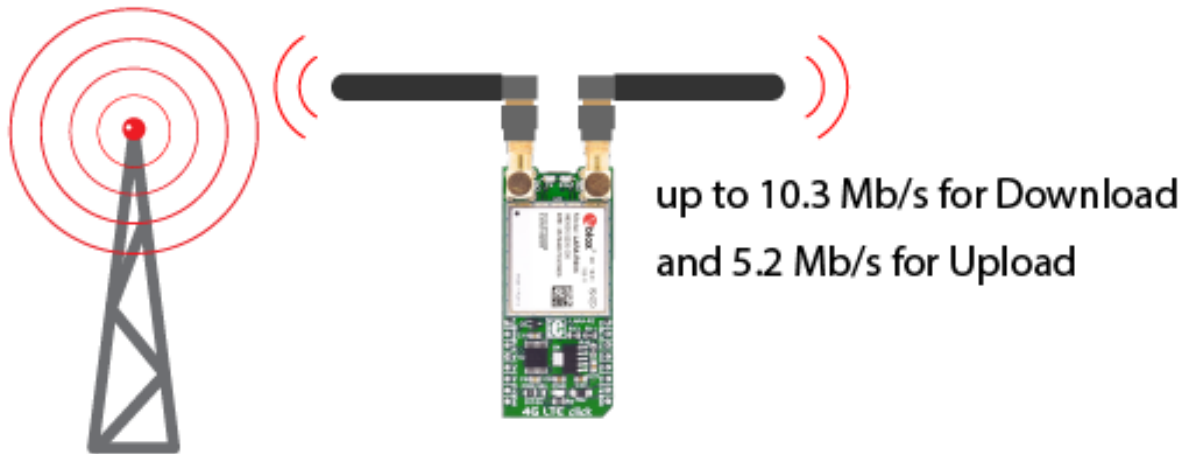

LARA-R204 overview

With a range of interface options and an integrated IP stack, the modules are designed to support a wide range of data-centric applications. The unique combination of performance and flexibility make these modules ideally suited for medium speed M2M applications, such as smart energy gateways, remote access video cameras, digital signage, telehealth, and telematics.

4G LTE-NA click overview

The board has a rich set of components to simplify development: two SMA connectors, a MicroUSB port, as well as a SIM card slot.

The LARA-R204 module specifies data rates of up to 10.3 Mb/s for Download, and 5.2 Mb/s for Upload. The network protocol stack includes support for TCP, UDP, PPP, MMS, FTP, SMTP, SMTPS, HTTP, HTTPS, PING, and SSL. It covers following LTE bands: 4, 13.

Antenna interfaces - The module has two RF pins with a characteristic impedance of 50 Ω . The primary antenna pin (ANT1) supports both Tx and Rx, providing the main antenna interface, while the secondary antenna pin (ANT2) supports Rx only for the LTE Rx **diversity configuration**.

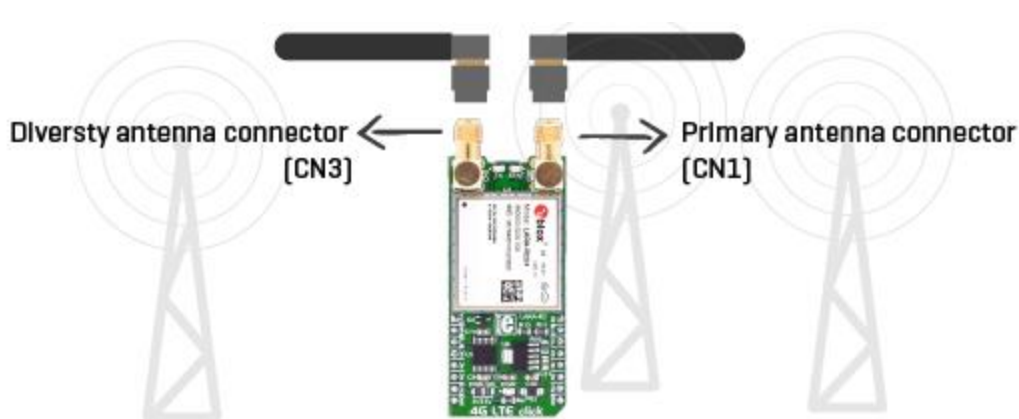

A diversity antenna only covers the Rx frequencies, and its job is to acquire an independent sample of data. The application in which you are using the click board can then choose the receive signal it wants to use.

Free u-blox software

u-blox offers **m-centre**, a [free evaluation software](#) for all their cellular modules. It is an easy to use graphical interface where you can configure the module and save the changes on EPROM. You can also view and edit SIM phonebook entries, send text messages, and communicate with the wireless module using AT commands.

4G LTE explained

Simply put 4G is the fourth generation of the cellular network standard. This fourth generation does not support traditional circuit-switched telephony service, but all IP based communication such as IP telephony.

If you are not familiar with cellular network standards and protocols and are not sure whether you need GSM or 3G or 4G, read our learn.mikroe.com [article about 2G/3G/4G](#) to get a better understanding.

LTE or Long Term Evolution, or 4G LTE as it is most commonly called has different categories defined. There are nine different ones so far. LARA-R204 module supports the **LTE Cat 1**.

Specifications

Type	GSM
Applications	medium speed M2M applications, such as smart energy gateways, remote access video cameras, digital signage, telehealth, and telematics, and more
MCU	LARA-R204 cellular module from u-blox
Key Features	Data rates of up to 10.3 Mb/s for Download, Data rates of up to 5.2 Mb/s for Upload, Covering the following LTE bands: 4,13; Micro SIM card socket, SMA antenna connectors, micro USB connector
Interface	UART,GPIO
Input Voltage	3.3V or 5V
Compatibility	mikroBUS
Click board size	L (57.15 x 25.4 mm)

Pinout diagram

This table shows how the pinout on **4G LTE-NA click** corresponds to the pinout on the mikroBUS™ socket (the latter shown in the two middle columns).

Notes	Pin					Pin	Notes
Module status	STA	1	AN	PWM	16	RI	Ring indicator
Power up module	PWK	2	RST	INT	15	CTS	UART Clear to send
UART Ready to send	RTS	3	CS	TX	14	TXD	UART Transmit data
	NC	4	SCK	RX	13	RXD	UART Receive data
	NC	5	MISO	SCL	12	NC	
	NC	6	MOSI	SDA	11	NC	
Power supply	+3.3V	7	3.3V	5V	10	+5V	Power supply
Ground	GND	8	GND	GND	9	GND	Ground

Jumpers and settings

Designator	Name	Default Position	Default Option	Description
JP1	I/O SEL.	Left	3V3	Power Supply Voltage Selection 3V3/5V, left position 3v3, right position 5v

Buttons and LEDs

Designator	Name	Type (LED, BUTTON...)	Description
LD1	NET	LED	Network status LED.
LD2	STAT.	LED	Module Power On status.