

**SANYO**

No. 4740

**STK730-080****Self-Excitation Type Semi-Regulated  
Switching Regulator (210 W Output)****Overview**

The STK730-080 provides on-chip the power switching, error detection, amplifier, and overcurrent protection circuits required in a self-excitation type semi-regulated switching regulator. As a result, it can be used to construct a switching power supply with a minimal number of external components. Furthermore, due to the adoption of MOSFETs as the power switching elements, an oscillator frequency higher than that possible with bipolar transistors can be used. This allows miniaturized power supply systems to be constructed by reducing the size of the pulse transformer and capacitors.

**Applications**

- Power supplies in CRT and CTV products
- Power supplies in office automation products
- Switching power supplies in general

**Features**

- Power MOSFETs adopted
- Built-in error detection circuit
- Built-in overcurrent protection circuit
- Product series differentiated by output capacity (110 to 280 W)
- Few external components required
- Since the STK730-080 supports higher oscillator frequencies, smaller pulse transformers can be used.
- Takes all major national stability standards and EMF hazard standards into consideration.
- The IMST (insulated metal substrate technology) substrate functions as an EMF shield plate and supports low noise design.

**Package Dimensions**

unit: mm

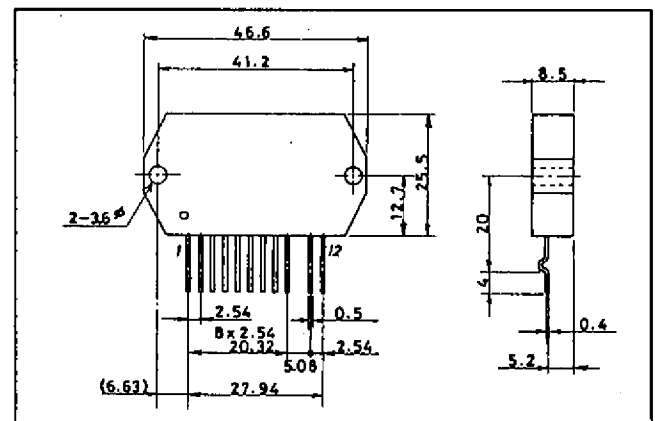
**4121**

## Specifications

### Maximum Ratings at $T_a = 25^\circ\text{C}$ ( $T_c = 25^\circ\text{C}$ unless specified otherwise)

Parameter	Symbol	Condition	Rating	Unit
Operating substrate temperature	$T_c$ max	*1	115	$^\circ\text{C}$
AC input voltage	$V_{AC}$	*2	280	Vrms
Operating temperature	$T_{opr}$		-10 to +85	$^\circ\text{C}$
Storage temperature	$T_{stg}$		-30 to +115	$^\circ\text{C}$
Maximum output power	$W_o$ max	*2 When $V_O = 135\text{ V}$	210	W
[TR1]				
Drain current	$I_D$	*3	6	A
Pulse drain current	$I_D$ (puls)	*3	15	A
Drain reverse current	$I_{DR}$		6	A
Gate-source voltage	$V_{GSS}$		$\pm 30$	V
Allowable power dissipation	$P_d$		100	W
Chip junction temperature	$T_J$ max		150	$^\circ\text{C}$
Thermal resistance	$\theta_{j-c}$		1.25	$^\circ\text{C/W}$
[ZD1]				
Allowable power dissipation	$P_{ZD1}$		500	mW
Chip junction temperature	$T_J$ (ZD1) max		125	$^\circ\text{C}$
Thermal resistance	$\theta_{j-c}$ (ZD1)		0.2	$^\circ\text{C/mW}$

Note: 1. The recommended substrate temperature is  $105^\circ\text{C}$  (maximum).  
 2. In the specified test circuit  
 3. See the ASO characteristics for these values in overcurrent states.

### Recommended Operating Conditions at $T_a = 25^\circ\text{C}$

Parameter	Symbol	Condition	Rating	Unit
Pin 4 input voltage	$V_4$		$\pm 8$ to $\pm 24$	V
Oscillator frequency	$f_{osc}$		20 to 120	kHz

### Operating Characteristics at $T_a = 25^\circ\text{C}$ ( $T_c = 25^\circ\text{C}$ unless specified otherwise)

Parameter	Symbol	Condition	Rating			Unit
			min	typ	max	
Output voltage setting		* $I_{in} = 8\text{ mA}$	40.0	40.5	41.0	V
Output voltage temperature coefficient		* $T_c = 0$ to $+105^\circ\text{C}$ , $I_{in} = 8\text{ mA}$		7		mV/ $^\circ\text{C}$
[TR1]						
Drain-source breakdown voltage	$V_{(BR)DSS}$	$I_D = 10\text{ mA}$ , $V_{GS} = 0\text{ V}$	900			V
Gate-source cutoff voltage	$V_{GS}$ (off)	$I_D = 1\text{ mA}$ , $V_{DS} = 10\text{ V}$	2.0		3.0	V
On resistance	$R_{DS}$ (on)	$I_D = 3\text{ A}$ , $V_{GS} = 10\text{ V}$		2.0	3.0	$\Omega$
Input capacitance	$C_{iss}$	$V_{DS} = 10\text{ V}$ , $V_{GS} = 0\text{ V}$ , $f = 1\text{ MHz}$		1200		pF
[ZD1]						
Zener voltage	$V_Z$	$I_Z = 5\text{ mA}$	23.7		26.3	V

Note: \* In the specified test circuit

Equivalent Circuit Block Diagram

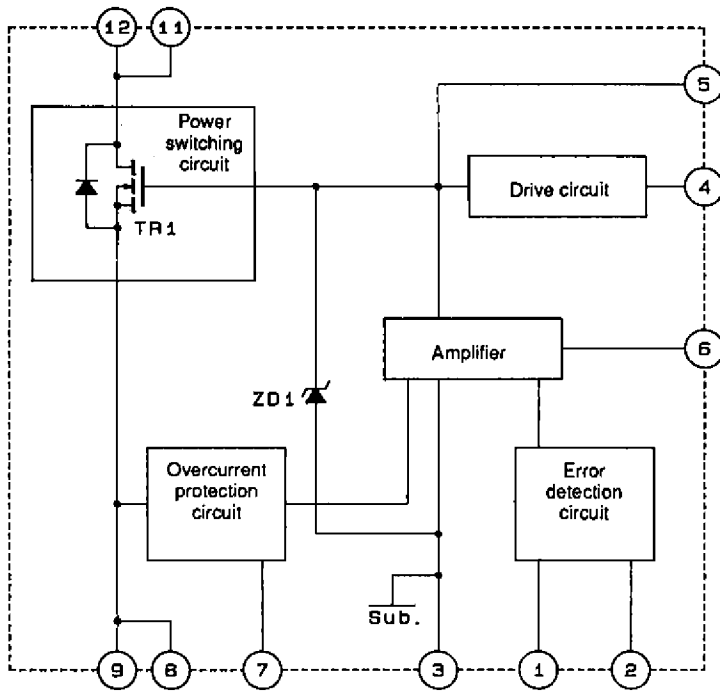

Pin No.	Description
1	Vref (40.5 V typical) input
2	Error detection level
3	Ground
4	Drive voltage input
5	TR1 gate
6	Amplifier circuit control
7	OCF setting level input
8	TR1 source
9	TR1 source
11	TR1 drain
12	TR1 drain

A01842

Note: The back surface of the IC is not an insulator, and may be shorted to pin 3.

Application Circuit Example

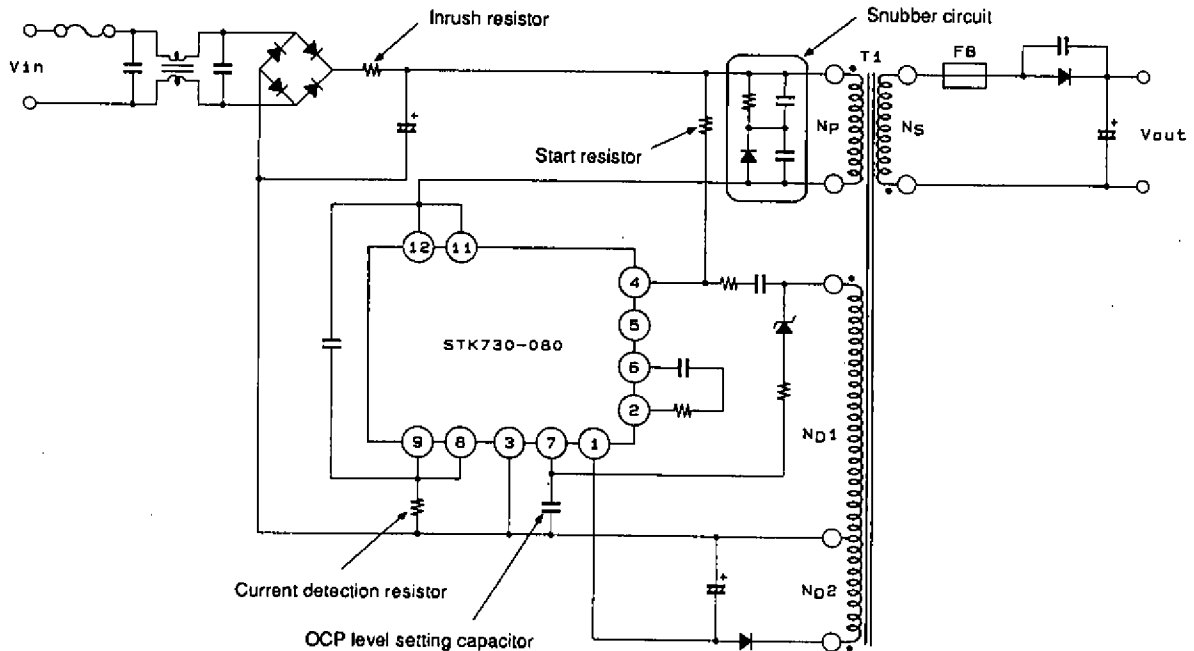

A01843

**Characteristics Data**

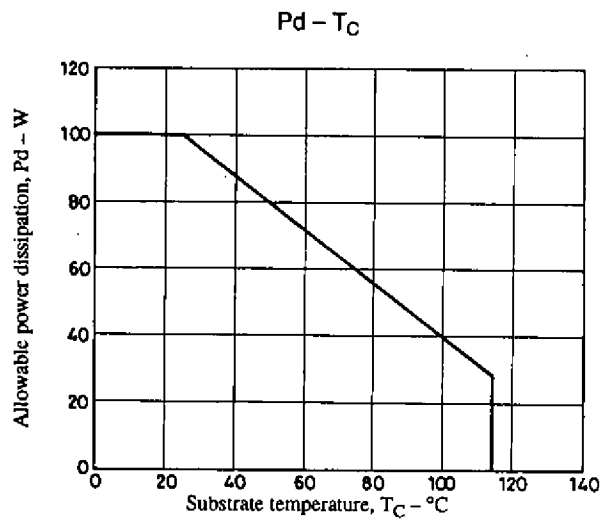
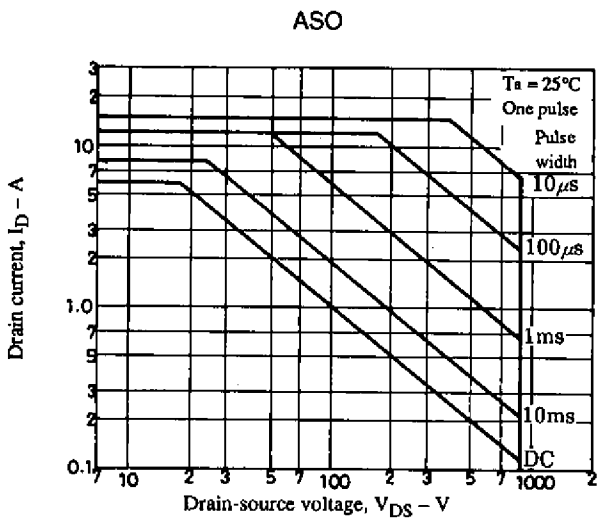

**Series Organization**

These products are provided as a product series whose members differ mainly in their power capacity. Note that the following table includes products that are under development. Contact your Sanyo sales representative for information on product availability.

Product No.	Maximum Rating					Operating Characteristic		
	V <sub>DSS</sub>	T <sub>stg</sub> *	T <sub>c</sub> max	T <sub>j</sub> max	I <sub>D</sub>	AC Input range	W <sub>o</sub> max	R <sub>on</sub> typ.
	V	°C	°C	°C	A	V	W	Ω
STK730-010	500	-30 to +115	+115	+150	6.0	85 to 132	110	1.4
STK730-020					8.0		145	0.8
STK730-030					10.0		180	0.7
STK730-040					12.0		210	0.55
STK730-050					15.0		280	0.3
STK730-060	900	-30 to +115	+115	+150	3.0	170 to 264	110	5.0
STK730-070					5.0		180	3.0
STK730-080					6.0		210	2.0
STK730-090					8.0		280	1.2

Note: \* The recommended substrate temperature is 105°C (maximum).

- No products described or contained herein are intended for use in surgical implants, life-support systems, aerospace equipment, nuclear power control systems, vehicles, disaster/crime-prevention equipment and the like, the failure of which may directly or indirectly cause injury, death or property loss.
- Anyone purchasing any products described or contained herein for an above-mentioned use shall:
  - ① Accept full responsibility and indemnify and defend SANYO ELECTRIC CO., LTD., its affiliates, subsidiaries and distributors and all their officers and employees, jointly and severally, against any and all claims and litigation and all damages, cost and expenses associated with such use;
  - ② Not impose any responsibility for any fault or negligence which may be cited in any such claim or litigation on SANYO ELECTRIC CO., LTD., its affiliates, subsidiaries and distributors or any of their officers and employees jointly or severally.
- Information (including circuit diagrams and circuit parameters) herein is for example only; it is not guaranteed for volume production. SANYO believes information herein is accurate and reliable, but no guarantees are made or implied regarding its use or any infringements of intellectual property rights or other rights of third parties.