



## LEISTUNGSERKLÄRUNG



Nr. 0019 – DE

1. Eindeutiger Kenncode des Produkttyps: **fischer Highbond-Anker FHB II**

2. Verwendungszweck(e):

Produkt	Verwendungszweck (e)
Verbundanker für die Verwendung in Beton	Nachträgliche Befestigung im gerissenen und ungerissenen Beton, siehe Anhang, insbesondere Anhänge B 1 bis B 9

3. Hersteller: **fischerwerke GmbH & Co. KG, Klaus-Fischer-Straße 1, 72178 Waldachtal, Deutschland**

4. Bevollmächtigter: --

5. System(e) zur Bewertung und Überprüfung der Leistungsbeständigkeit: **1**

6a. Harmonisierte Norm: ---

Notifizierte Stelle(n): ---

6b. Europäisches Bewertungsdokument: **ETAG 001; 2013-04**

Europäische Technische Bewertung: **ETA-05/0164; 2017-01-24**

Technische Bewertungsstelle: **DIBt**

Notifizierte Stelle(n): **1343 – MPA Darmstadt**

7. Erklärte Leistung(en):

### Mechanische Festigkeit und Standsicherheit (BWR 1)

Wesentliches Merkmal	Leistung
Charakteristische Werte für Zug- und Querbeanspruchung	Siehe Anhang, insbesondere Anhänge C 1 bis C 4
Verschiebungen unter Zug- und Querbeanspruchung	Siehe Anhang, insbesondere Anhang C 5 bis C 6

### Brandschutz (BWR 2)

Wesentliches Merkmal	Leistung
Brandverhalten	Der Dübel erfüllt die Anforderungen der Klasse A 1
Feuerwiderstand	KLF

8. Angemessene Technische Dokumentation und/oder Spezifische Technische Dokumentation: ---

Die Leistung des vorstehenden Produkts entspricht der erklärten Leistung/den erklärten Leistungen. Für die Erstellung der Leistungserklärung im Einklang mit der Verordnung (EU) Nr. 305/2011 ist allein der obengenannte Hersteller verantwortlich.

Unterzeichnet für den Hersteller und im Namen des Herstellers von:

Andreas Bucher, Dipl.-Ing.

Wolfgang Hengesbach, Dipl.-Ing., Dipl.-Wirtsch.-Ing.

*i.V. A. Bucher*

*i.V. W. Hengesbach*

Tumlingen, 2017-01-31

- Diese Leistungserklärung wurde in verschiedenen Sprachversionen erstellt. Für den Fall unterschiedlicher Auslegung hat immer die englische Version Vorrang.

- Der Anhang enthält freiwillige und ergänzende Informationen in englischer Sprache. Diese gehen über die (sprachneutral angegebenen) gesetzlichen Anforderungen hinaus.

## Specific Part

### 1 Technical description of the product

The fischer Highbond-Anchor FHB II is a torque controlled bonded anchor consisting of a mortar cartridge with mortar fischer FIS HB or fischer mortar capsule FHB II–P(F) and an anchor rod FHB II - A L or FHB II - A S with hexagon nut and washer.

The glass capsule is set into a drilled hole in the concrete. The special formed anchor rod is driven into the glass capsule by machine with simultaneous hammering and turning. For the injection system the anchor rod is placed into a drilled hole filled with injection mortar. The load transfer is realised by mechanical interlock of several cones in the bonding mortar and then via a combination of bonding and friction forces in the anchorage ground (concrete).

The product description is given in Annex A.

### 2 Specification of the intended use in accordance with the applicable European Assessment Document

The performances given in Section 3 are only valid if the anchor is used in compliance with the specifications and conditions given in Annex B.

The verifications and assessment methods on which this European Technical Assessment is based lead to the assumption of a working life of the anchor of at least 50 years. The indications given on the working life cannot be interpreted as a guarantee given by the producer, but are to be regarded only as a means for choosing the right products in relation to the expected economically reasonable working life of the works.

### 3 Performance of the product and references to the methods used for its assessment

#### 3.1 Mechanical resistance and stability (BWR 1)

Essential characteristic	Performance
Characteristic values under tension and shear load	See Annex C 1 to C 4
Displacements under tension and shear loads	See Annex C 5 and C 6

#### 3.2 Safety in case of fire (BWR 2)

Essential characteristic	Performance
Reaction to fire	Anchorage satisfy requirements for Class A1
Resistance to fire	No performance assessed

#### 3.3 Hygiene, health and the environment (BWR 3)

Regarding dangerous substances there may be requirements (e.g. transposed European legislation and national laws, regulations and administrative provisions) applicable to the products falling within the scope of this European Technical Assessment. In order to meet the provisions of Regulation (EU) No 305/2011, these requirements need also to be complied with, when and where they apply.

#### 3.4 Safety in use (BWR 4)

The essential characteristics regarding Safety in use are included under the Basic Works Requirement Mechanical resistance and stability.

**4 Assessment and verification of constancy of performance (AVCP) system applied, with reference to its legal base**

In accordance with guideline for European technical approval ETAG 001, April 2013, used as European Assessment Document (EAD) according to Article 66 Paragraph 3 of Regulation (EU) No 305/2011, the applicable European legal act is: [96/582/EC].

The system to be applied is: 1

**Installation conditions**

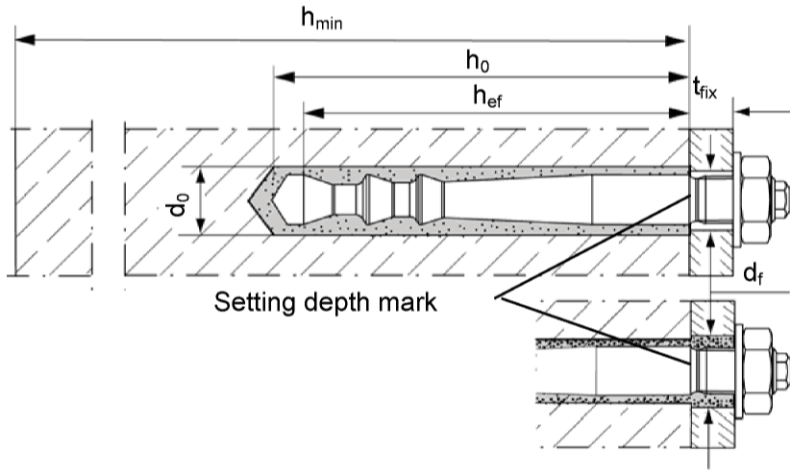

**Highbond-Anchor  
FHB II - A L**  
Pre-positioned anchor

**Highbond-Anchor  
FHB II - A L**  
Push through anchor  
(not with mortar capsule)  
annular gap filled with mortar

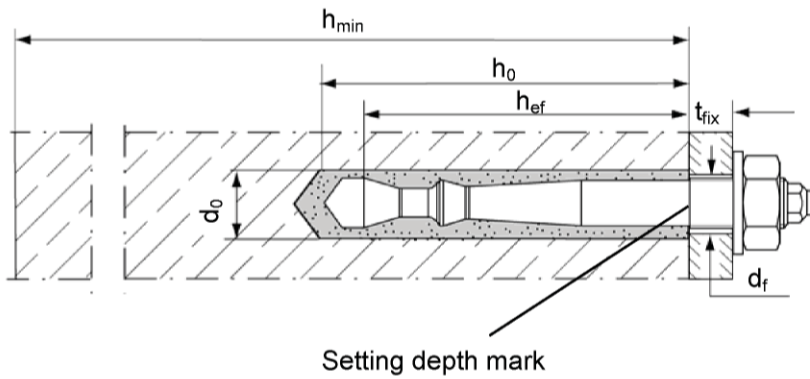



**Highbond-Anchor  
FHB II - A S**  
Pre-positioned anchor  
and push through anchor

fischer Highbond-Anchor FHB II

**Product description**  
Installation condition

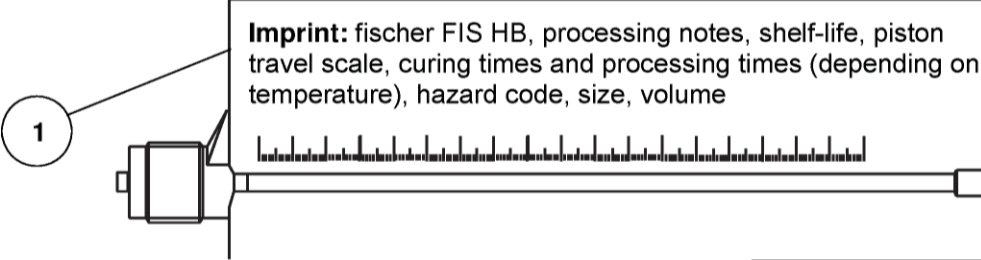
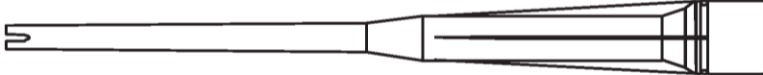
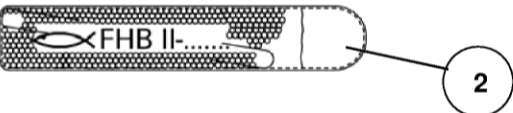
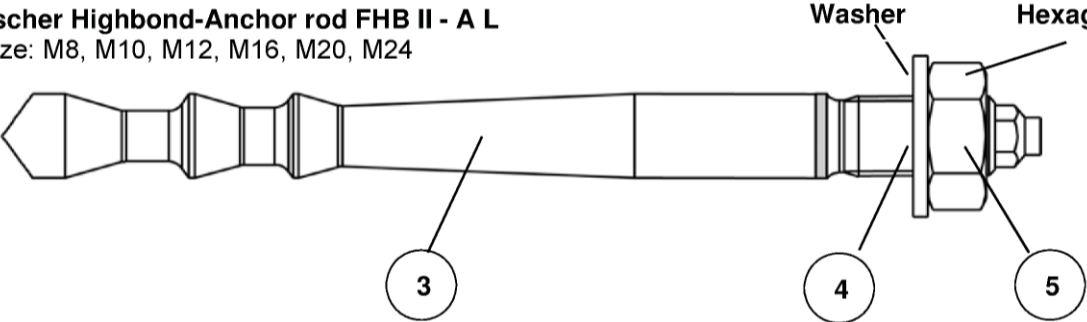
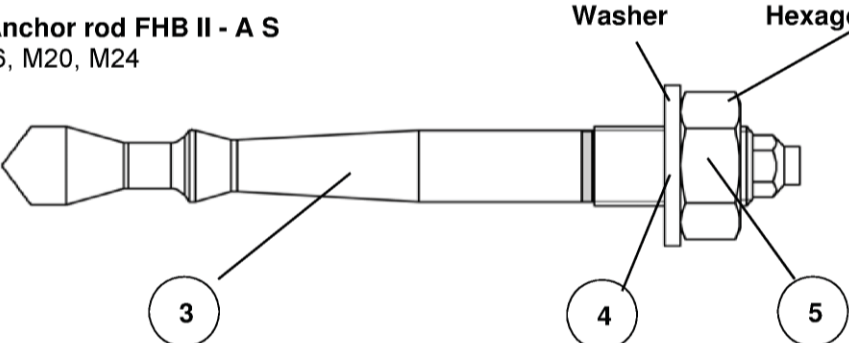

**Annex A 1**

<p style="text-align: center;"><b>Cartridge sizes 150 ml, 300 ml (Coaxial cartridge) 360 ml, 950 ml (Shuttle cartridge)</b></p> <div style="display: flex; justify-content: space-between;"> <div style="width: 15%;"> <p><b>Sealing cap</b></p>  </div> <div style="width: 80%;">  <p><b>Static mixer FIS MR or FIS UMR</b></p>  <p><b>Extension tube</b></p> </div> </div> <p><b>fischer mortar capsule FHB II-P or FHB II-PF</b></p>  <p><b>fischer Highbond-Anchor rod FHB II - A L</b> Size: M8, M10, M12, M16, M20, M24</p>  <p><b>fischer Highbond-Anchor rod FHB II - A S</b> Size: M10, M12, M16, M20, M24</p> 	<p><b>Imprint: fischer FIS HB, processing notes, shelf-life, piston travel scale, curing times and processing times (depending on temperature), hazard code, size, volume</b></p> 
<p>fischer Highbond-Anchor FHB II</p> <hr/> <p><b>Product description</b> Cartridges / Static mixer / Mortar capsule / Steel elements</p>	<p><b>Annex A 2</b></p>

<b>Table A1: Materials</b>				
<b>Part</b>	<b>Designation</b>	<b>Material</b>		
1	Mortar cartridge	Mortar, hardener, filler		
2	Mortar capsule	Mortar, hardener, filler		
	Steel grade	Steel, zinc plated	Stainless steel A4	High corrosion resistant steel C
3	fischer Highbond- Anchor rod FHB II - A L or FHB II - A S	Property class 8.8; EN ISO 898-1:2013 zinc plated $\geq 5 \mu\text{m}$ , EN ISO 4042:1999 A2K $f_{uk} \leq 1000 \text{ N/mm}^2$ $A_5 > 12 \%$ fracture elongation	Property class 80 EN ISO 3506-1:2009 1.4401; 1.4404; 1.4578; 1.4571; 1.4439; 1.4362; 1.4062, 1.4662, 1.4462 EN 10088-1:2014 $f_{uk} \leq 1000 \text{ N/mm}^2$ $A_5 > 12 \%$ fracture elongation	Property class 80 EN ISO 3506-1:2009 1.4565; 1.4529 EN 10088-1:2014 $f_{uk} \leq 1000 \text{ N/mm}^2$ $A_5 > 12 \%$ fracture elongation
4	Washer ISO 7089:2000	zinc plated $\geq 5 \mu\text{m}$ , EN ISO 4042:1999 A2K	1.4401; 1.4404; 1.4578;1.4571; 1.4439; 1.4362 EN 10088-1:2014	1.4565;1.4529 EN 10088-1:2014
5	Hexagon nut	Property class 8; EN ISO 898-2:2012 zinc plated $\geq 5 \mu\text{m}$ , ISO 4042:1999 A2K	Property class 70 EN ISO 3506-1:2009 1.4401; 1.4404; 1.4578; 1.4571; 1.4439; 1.4362 EN 10088-1:2014	Property class 70 EN ISO 3506-1:2009 1.4565; 1.4529 EN 10088-1:2014
fischer Highbond-Anchor FHB II				<b>Annex A 3</b>
Product description Materials				

**Specifications of intended use (part 1)**

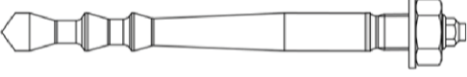
**Table B1:** Overview use and performance categories

Anchorages subject to		<b>fischer Injection mortar FIS HB or fischer mortar capsule FHB II-P or FHB II-PF with ...</b>	
		<b>FHB II – A L</b> 	<b>FHB II – A S</b> 
Hammer drilling with standard drill bit		All sizes	
Static or quasi static load, in	uncracked concrete	all sizes Tables: C1, C3, C5	all sizes Tables: C2, C4, C6
	cracked concrete		
Use category	dry or wet concrete	all sizes	
	flooded hole	all sizes (only with mortar capsule allowed)	
Kind of installation	Pre-positioned anchor	all sizes	
	Push through anchor	all sizes (only with injection mortar FIS HB allowed)	all sizes
Installation temperature		-5 C to +40 C	
In-service temperature		-40°C to +80°C (max. long term temperature +50°C and max. short term temperature +80°C)	

fischer Highbond-Anchor FHB II

**Intended Use**  
Specifications (part 1)

**Annex B 1**

**Specifications of intended use (part 2)**

**Base materials:**

- Reinforced or unreinforced normal weight concrete Strength classes C20/25 to C50/60 according to EN 206-1:2000

**Use conditions (Environmental conditions):**

- Structures subject to dry internal conditions (zinc coated steel, stainless steel or high corrosion resistant steel)
- Structures subject to external atmospheric exposure (including industrial and marine environment) and to permanently damp internal condition, if no particular aggressive conditions exist (stainless steel or high corrosion resistant steel)
- Structures subject to external atmospheric exposure, to permanently damp internal conditions or in other particular aggressive conditions (high corrosion resistant steel)

Note: Particular aggressive conditions are e.g. permanent, alternating immersion in seawater or the splash zone of seawater, chloride atmosphere of indoor swimming pools or atmosphere with extreme chemical pollution (e.g. in desulphurization plants or road tunnels where de-icing materials are used)

**Design:**

- Anchorages have to be designed by a responsible engineer with experience of concrete anchor design
- Verifiable calculation notes and drawings are to be prepared taking account of the loads to be anchored. The position of the anchor is indicated on the design drawings (e.g. position of the anchor relative to reinforcement or to supports, etc.)
- Anchorages under static or quasi-static actions are designed in accordance with
- EOTA ETAG 001 Annex C, 08/2010 or CEN/TS 1992-4:2009

**Installation:**

- Anchor installation is to be carried out by appropriately qualified personnel and under the supervision of the person responsible for technical matters of the site
- In case of aborted hole: The hole shall be filled with mortar
- Observe the effective anchorage depth
- Overhead installation is allowed

fischer Highbond-Anchor FHB II

**Intended Use**  
Specifications (part 2)

**Annex B 2**



**Table B2:** Installation parameters for fischer Highbond-Anchor rods FHB II – A L

Size FHB II – A L		M8x 60	M10x 95	M12x 100   120		M16x 125   145   160			M20x 210	M24x 210
Corresponding mortar capsules <b>FHB II-P or FHB II-PF</b>	[-]	8x60	10x95	12x 100	12x 120	16x 125	16x 145	16x 160	20x 210	24x 210
Cone diameter	$d_k$	9,4	10,7	12,5		16,8			23,0	
Width across flats	SW	13	17	19		24			30	36
Nominal drill bit diameter	$d_0$	10	12	14		18			25	
Drill hole depth	$h_0$	75	110	115	135	140	160	175	235	
Effective anchorage depth	$h_{ef}$	60	95	100	120	125	145	160	210	
Minimum spacing and minimum edge distance	$s_{min} = c_{min}$	40		50		55	60	70	90	
Diameter of clearance hole in the fixture <sup>1)</sup>	pre-positioned anchorage $d_f \leq$	9	12	14		18			22	
	push through anchorage <sup>2)</sup> $d_f \leq$	11	14	16		20			26	
Minimum thickness of concrete member	$h_{min}$	100	140		170		190	220	280	
Installation torque	$T_{inst}$ [Nm]	15	20	40		60			100	
Thickness of fixture	$t_{fix} \leq$ [mm]	1500								

<sup>1)</sup> For larger clearance holes in the fixture see EOTA ETAG 001 Annex C, 08/2010 or CEN/TS 1992-4-:2009

<sup>2)</sup> Only with mortar capsule system

**FHB II – A L:**

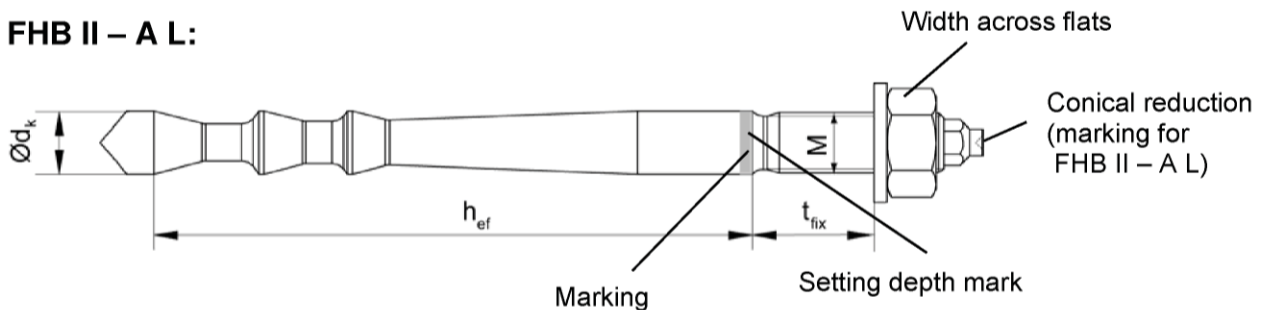

Alternative point version  
(only with injection mortar FIS HB)

Alternative head version

**Marking:**

Work symbol, size of anchor, setting depth. e. g.: M10x95

For stainless steel additional **A4**. For high corrosion resistant steel additional **C**.

For high corrosion resistant steel additional marking **C** also on the face.

fischer Highbond-Anchor FHB II

**Intended Use**

Installation parameters fischer Highbond-Anchor rod FHB II – A L

**Annex B 3**

**Table B3:** Installation parameters for fischer Highbond-Anchor rods FHB II – A S

Size FHB II – A S	M10x		M12x	M16x	M20x	M24x	
	60	75	75	95	170	170	
Corresponding mortar capsules <b>FHB II-P</b> or <b>FHB II-PF</b>	[-]		10x60	10x75	12x75	16x95	20x170 24x170
Cone diameter $d_k$	9,4		11,3	16,8	23,0		
Width across flats SW	17		19	24	30	36	
Nominal drill bit diameter $d_0$	10		12	16	25		
Drill hole depth $h_0$	75	90	90	110	190		
Effective anchorage depth $h_{ef}$	60	75	75	95	170		
Minimum spacing and minimum edge distance $s_{min} = c_{min}$	40			50	80		
Diameter of clearance hole in the fixture <sup>1)</sup>	pre-positioned anchorage $d_f \leq$	12		14	18	22	26
	push through anchorage $d_f \leq$	12		14	18	26	
Minimum thickness of concrete member $h_{min}$	100	120		150	240		
Installation torque $T_{inst}$	[Nm]		15	30	50	100	
Thickness of fixture $t_{fix} \leq$	[mm]		1500				

<sup>1)</sup> For larger clearance holes in the fixture see EOTA ETAG 001 Annex C, 08/2010 or CEN/TS 1992-4-:2009

**FHB II – A S:**

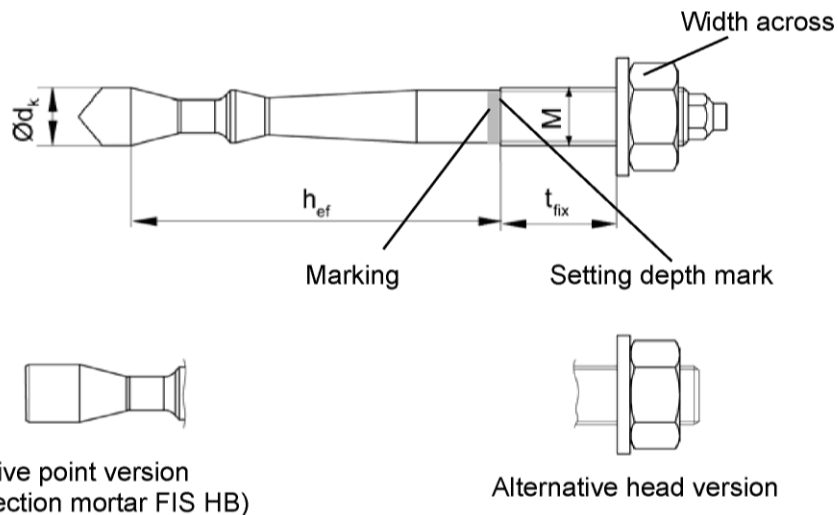

**Marking:**

Work symbol, size of anchor, setting depth. e. g.: M10x75

For stainless steel additional **A4**. For high corrosion resistant steel additional **C**.  
For high corrosion resistant steel additional marking **C** also on the face.

fischer Highbond-Anchor FHB II

**Intended Use**

Installation parameters fischer Highbond-Anchor rod FHB II – A S

**Annex B 4**

**Table B4:** Dimensions of mortar capsules FHB II-P and FHB II-PF

Capsule		8x		10x		12x			16x				20x		24x	
		60	60	75	95	75	100	120	95	125	145	160	170	210	170	210
Length of capsule	$L_p$	85		90	115	95	120			150	155	185	210	185	210	
Diameter of capsule	$\varnothing d_p$	9			11		12,5	14,5	17				21,5			

**FHB II-P (standard)**

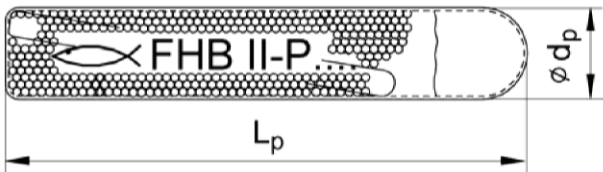

**FHB II-PF (fast curing)**

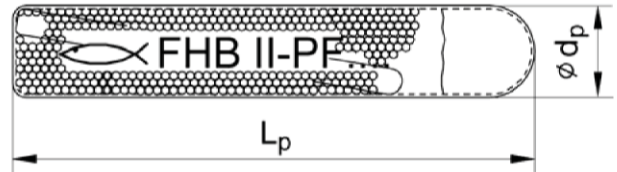

**Imprint:** work symbol, marking, anchor size and effective anchorage depth.

e.g :  FHB II-P 12x100 or.

 FHB II-PF 12x100

**Table B5:** Parameters of steel brush FIS BS  $\varnothing$   
(only when using injection mortar)

Drill bit diameter	$d_0$	[mm]	10	12	14	16	18	25
Steel brush diameter	$d_b$		11	14	16	20		27



fischer Highbond-Anchor FHB II

**Intended Use**  
Dimensions of mortar capsules  
Parameters of steel brush

**Annex B 5**

**Table B6: Maximum processing time of the mortar FIS HB and minimum curing time**  
(During the curing time of the mortar the concrete temperature may not fall below the listed minimum temperature)

System temperature [°C]	Maximum processing time $t_{work}$ [minutes]	Minimum curing time <sup>1)</sup> $t_{cure}$ [minutes]
-5 to ±0	----	6 hours
> +1 to +5	----	3 hours
> +6 to +10	15	90
> +11 to +20	6	35
> +21 to +30	4	20
> +31 to +40	2	12

<sup>1)</sup> In wet concrete the curing times must be doubled

**Table B7: Minimum curing time for mortar capsules FHB II-P and FHB II-PF**  
(During the curing time of the mortar the concrete temperature may not fall below the listed minimum temperature)

Mortar capsule FHB II-P (standard)		Mortar capsule FHB II-PF (fast curing)	
System temperature [°C]	Minimum curing time <sup>1)</sup> $t_{cure}$ [minutes]	System temperature [°C]	Minimum curing time <sup>1)</sup> $t_{cure}$ [minutes]
-5 to ±0	4 Stunden	-5 to ±0	8
> +1 to +10	45	> +1 to +10	6
> +11 to +20	20	> +11 to +20	4
> +20	10	> +20	2

<sup>1)</sup> In wet concrete or flooded holes the curing times must be doubled

fischer Highbond-Anchor FHB II

**Intended Use**  
Processing times and curing times

**Annex B 6**

**Installation instruction part 1**

**Installation with mortar capsule FHB II-P or FHB II-PF**

**Drilling the hole**

<b>1</b>		<p>Drill the hole with hammer drill.                  Drill hole diameter <math>d_0</math> and drill hole depth <math>h_0</math> see  <b>Tables B2, B3</b></p> <p>Cleaning of the bore hole is not necessary</p>
----------	---	--

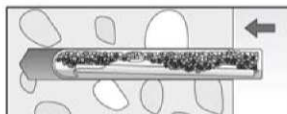

**Installation Highbond-Anchor rod FHB II – A L and FHB II – A S**

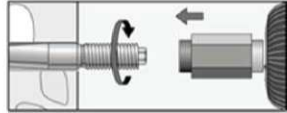
<b>2</b>		<p>Put the mortar capsule FHB II-P or FHB II-PF into the bore hole</p>
----------	---	--

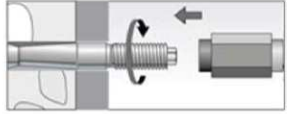
<b>3</b>		<p><b>Pre-positioned anchor:</b> Only use Highbond-Anchor rods FHB II - A L or FHB II – A S with <b>roof-shaped point</b>. Drive in the Anchor rod using a hammer drill or impact drill. When reaching the setting depth mark stop the drill immediately.</p>
----------	---	---

<b>3</b>		<p><b>Push through anchor:</b> Only use Highbond-Anchor rods <b>FHB II – A S</b> with <b>roof-shaped point</b>. Drive in the anchor rod using a hammer drill or impact drill. When reaching the setting depth mark stop the drill immediately.</p>
----------	--	--

<b>4</b>		<p>After inserting the anchor, excess mortar must be emerged around the anchor.</p>
----------	---	---

<b>4</b>		<p>For overhead installations support the anchor rod with wedges.                  (e.g. fischer centering wedges)</p>	
----------	---	--	---

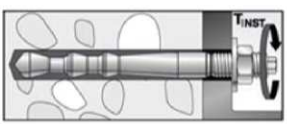
<b>5</b>		<p>Wait for the specified curing time  <math>t_{cure}</math> see <b>Table B7</b></p>	<b>6</b>		<p>Mounting the fixture  <math>T_{inst}</math> see  <b>Tables B2 and B3</b></p>
----------	---	--	----------	--	---







fischer Highbond-Anchor FHB II		<b>Annex B 7</b>
<p><b>Intended use</b>                  Installation instruction part 1</p>		



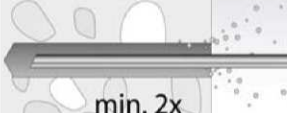

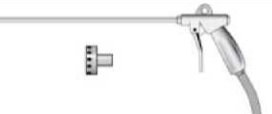
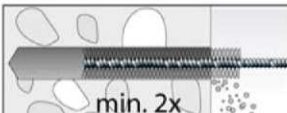



## Installation instruction part 2

### Installation with injection mortar FIS HB

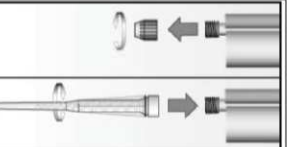
#### Drilling and cleaning the hole

1		<p>Drill the hole with hammer drill. Drill hole diameter <math>d_0</math> and drill hole depth <math>h_0</math> see <b>Tables B2, B3</b></p>
2		<p>Blow out the drill hole twice. If necessary, remove standing water out of the bore hole.</p>
		<p>For drill hole diameter <math>d_0 &lt; 25</math> mm with hand-blowout or oil-free compressed air</p>  <p>For drill hole diameter <math>d_0 = 25</math> mm with oil-free compressed air (<math>p \geq 6</math> bar) Use a cleaning nozzle.</p>
3		<p>Brush the bore hole twice. Corresponding brushes see <b>Table B5</b></p> 
4		<p>Blow out the drill hole twice.</p>
		<p>For drill hole diameter <math>d_0 &lt; 25</math> mm with hand-blowout or oil-free compressed air</p>  <p>For drill hole diameter <math>d_0 = 25</math> mm with oil-free compressed air (<math>p \geq 6</math> bar) Use a cleaning nozzle.</p>

#### Preparing the cartridge

5		<p>Remove the sealing cap Screw on the static mixer (the spiral in the static mixer must be clearly visible)</p>
6		<p>Place the cartridge into the dispenser</p> 
7		<p>Extrude approximately 10 cm of material until the resin is evenly grey in colour. Do not use mortar that is not uniformly grey</p> 
		<p>Observe the processing time, <math>t_{work}</math> see <b>Table B6</b></p> <p>If the processing time is exceeded, use a new static mixer and if necessary remove encrusted material in the cartridge mouth.</p>

fischer Highbond-Anchor FHB II

**Intended use**  
Installation instruction part 2



**Annex B 8**

### Installation instruction part 3

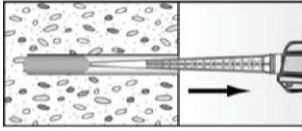
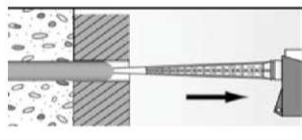
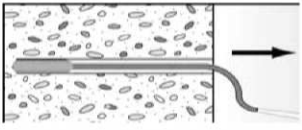
#### Injection of the mortar

		<p>Fill approximately 2/3 of the drill hole with mortar. Exact quantity of mortar (travel scale on the cartridge) see instruction sheet.</p> <p>Fill the drill hole with mortar, always begin from the bottom of the hole to avoid bubbles</p>
8		<p><b>Push-through installation:</b> By using Highbond-Anchor rods <b>FHB II-A L</b> the drill hole in the fixture must be also filled with mortar. <b>FHB II-A S</b> is this not necessary.</p>
		<p>For drill hole depth <math>\geq 170</math> mm use an extension tube</p>

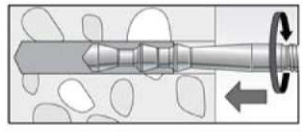
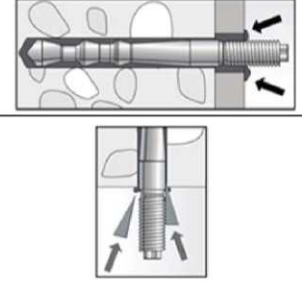
#### Installation Highbond-Anchor rod FHB II – A L and FHB II – A S

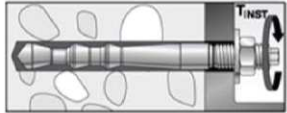
9		<p>Only use clean and oil-free anchor rods. Push the anchor rod down to the bottom of the hole, turning it slightly while doing so.</p>
10		<p>After inserting the anchor rod, excess mortar must be emerged around the anchor rod</p> <p>For overhead installations support the anchor rod with wedges. (e.g. fischer centering wedges)</p> 
11	 <p>Wait for the specified curing time <math>t_{cure}</math> see <b>Table B6</b></p>	<p>12</p>  <p>Mounting the fixture <math>T_{inst}</math> see <b>Tables B2 and B3</b></p>

fischer Highbond-Anchor FHB II

**Intended use**  
Installation instruction part 3

**Annex B 9**

<b>Table C1: Characteristic values under static or quasi-static tension load for fischer Highbond-Anchor FHB II – A L</b>											
Size FHB II – A L			M8x 60	M10x 95	M12x 100   120		M16x 125   145   160			M20x 210	M24x 210
<b>Bearing capacity under tensile load, steel failure</b>											
Characteristic resistance $N_{Rk,s}$	Steel, zinc plated	[kN]	25,1	34,4	49,8		96,6			137,6	
	Stainless steel A4		25,1	34,4	49,8		96,6			137,6	
	High corrosion resistant steel C										
<b>Partial safety factors<sup>1)</sup></b>											
Partial safety factor $\gamma_{Ms,N}$	Steel, zinc plated	[-]					1,5 <sup>1)</sup>				
	Stainless steel A4						1,5 <sup>1)</sup>				
	High corrosion resistant steel C						1,5 <sup>1)</sup>				
<b>Pullout failure in cracked concrete C20/25</b>											
Characteristic resistance	$N_{Rk,p}$	[kN]	--- <sup>3)</sup>								
<b>Pullout and splitting failure in uncracked concrete C20/25</b>											
Characteristic resistance	$N_{Rk,p}$	[kN]	--- <sup>3)</sup>								
Edge distance	$c_{cr,sp}$	[mm]	300	476	380	600	375	500	580	630	
Spacing	$s_{cr,sp}$		150	238	190	300	188	250	290	315	
<b>Pullout and splitting failure in uncracked concrete C20/25</b>											
Characteristic resistance	$N_{Rk,p}$ <sup>2)</sup>	[kN]	20	35	40	50	--- <sup>3)</sup>	75	95	--- <sup>3)</sup>	
Edge distance	$c_{cr,sp}$	[mm]	1,5 $h_{ef}$								
Spacing	$s_{cr,sp}$		3,0 $h_{ef}$								
<b>Factors for the compressive strength of concrete &gt; C20/25</b>											
Increasing factor for $N_{Rk,p}$	C25/30	$\Psi_c$	[-]	1,10							
	C30/37			1,22							
	C35/45			1,34							
	C40/50			1,41							
	C45/55			1,48							
	C50/60			1,55							
<b>Factors acc. to CEN/TS 1992-4:2009 Section 6.2.2.3</b>											
Uncracked concrete	$k_{ucr}$	[-]	10,1								
Cracked concrete	$k_{cr}$		7,2								
<b>Concrete cone failure</b>											
Effective anchorage depth	$h_{ef}$	[mm]	60	95	100	120	125	145	160	210	
Partial safety factor <sup>1) 5)</sup>	$\gamma_{Mc}$	[-]	1,5 <sup>4)</sup>	1,5							
<sup>1)</sup> In absence of other national regulations <sup>2)</sup> Proof of splitting failure acc. ETAG 001, Annex C, (Section 5.3). Instead of $N_{Rk,c}^0$ use $N_{Rk,p}$ . <sup>3)</sup> Not decisive (proof of splitting failure acc. ETAG 001, Annex C) <sup>4)</sup> With mortar capsule: $\gamma_{Mc} = 1,8$ <sup>5)</sup> $\gamma_2 = 1,0$ is included											
fischer Highbond-Anchor FHB II										<b>Annex C 1</b>	
<b>Performances</b> Characteristic values under static or quasi-static tension load for fischer Highbond-Anchor FHB II – A L (uncracked or cracked concrete)											



<b>Table C2: Characteristic values under static or quasi-static tension load for fischer Highbond-Anchor FHB II – A S</b>							
<b>Size FHB II – A S</b>		<b>M10x</b>		<b>M12x</b>	<b>M16x</b>	<b>M20x</b>	<b>M24x</b>
		<b>60</b>	<b>75</b>	<b>75</b>	<b>95</b>	<b>170</b>	<b>170</b>
<b>Bearing capacity under tensile load, steel failure</b>							
Characteristic resistance $N_{Rk,s}$	Steel, zinc plated	[kN]	25,1		34,4	61,6	128,5
	Stainless steel A4		25,1		34,4	61,6	128,5
	High corrosion resistant steel C		25,1		34,4	61,6	128,5
<b>Partial safety factors<sup>1)</sup></b>							
Partial safety factor $\gamma_{Ms,N}$	Steel, zinc plated	[-]			1,5 <sup>1)</sup>		
	Stainless steel A4				1,5 <sup>1)</sup>		
	High corrosion resistant steel C				1,5 <sup>1)</sup>		
<b>Pullout failure in cracked concrete C20/25</b>							
Characteristic resistance	$N_{Rk,p}$	[kN]	--- <sup>3)</sup>				
<b>Pullout and splitting failure in uncracked concrete C20/25</b>							
Characteristic resistance	$N_{Rk,p}$	[kN]	--- <sup>3)</sup>				
Edge distance	$c_{cr,sp}$	[mm]	300		340	510	
Spacing	$s_{cr,sp}$		150		170	255	
<b>Pullout and splitting failure in uncracked concrete C20/25</b>							
Characteristic resistance	$N_{Rk,p}$ <sup>2)</sup>	[kN]	20	25	40	--- <sup>3)</sup>	
Edge distance	$c_{cr,sp}$	[mm]	1,5 $h_{ef}$				
Spacing	$s_{cr,sp}$		3,0 $h_{ef}$				
<b>Factors for the compressive strength of concrete &gt; C20/25</b>							
Increasing factor for $N_{Rk,p}$	C25/30	$\Psi_c$	[-]	1,10			
	C30/37			1,22			
	C35/45			1,34			
	C40/50			1,41			
	C45/55			1,48			
	C50/60			1,55			
<b>Factors acc. to CEN/TS 1992-4:2009 Section 6.2.2.3</b>							
Uncracked concrete	$k_{ucr}$	[-]	10,1				
Cracked concrete	$k_{cr}$		7,2				
<b>Concrete cone failure</b>							
Effective anchorage depth	$h_{ef}$	[mm]	60	75	95	170	
Partial safety factor <sup>1)</sup>	$\gamma_{Mc}$	[-]	1,5 <sup>4)</sup>	1,5			
<sup>1)</sup> In absence of other national regulations <sup>2)</sup> Proof of splitting failure acc. ETAG 001, Annex C, (Section 5.3). Instead of $N_{Rk,c}^0$ use $N_{Rk,p}$ . <sup>3)</sup> Not decisive (proof of splitting failure acc. ETAG 001, Annex C) <sup>4)</sup> With mortar capsule: $\gamma_{Mc} = 1,8$ <sup>5)</sup> $\gamma_2 = 1,0$ is included							
fischer Highbond-Anchor FHB II							<b>Annex C 2</b>
<b>Performances</b> Characteristic values under static or quasi-static tension load for fischer Highbond-Anchor FHB II – A S (uncracked or cracked concrete)							

<b>Table C3: Characteristic values under static or quasi-static shear load for fischer Highbond-Anchor FHB II – A L (uncracked and cracked concrete)</b>									
Size FHB II – A L		M8x 60	M10x 95	M12x 100   120		M16x 125   145   160		M20x 210	M24x 210
<b>Bearing capacity under tensile load, steel failure</b>									
<b>without lever arm</b>									
Characteristic resistance	Steel, zinc plated	13,7	20,8	30,3		56,3		87,9	126,9
	Stainless steel A4 and High corrosion resistant steel C	15,2	23,2	33,7		62,7		97,9	141
		$V_{Rk,s}$	[kN]						
<b>with lever arm</b>									
Characteristic bending moment	Steel, zinc plated	31	62	105		266		519	896
	Stainless steel A4 and High corrosion resistant steel C	31	62	105		266		519	896
		$M^0_{Rk,s}$	[Nm]						
<b>Partial safety factors<sup>1)</sup></b>									
Partial safety factor	$\gamma_{Ms,V}$	[-]	1,25						
Ductility factor acc. to CEN/TS 1992-4-5:2009 Section 6.3.2.1	$k_2$	[-]	1,0						
<b>Concrete pry-out failure</b>									
Factor k acc. TR029 Section 5.2.3.3 or $k_3$ acc. CEN/TS 1992-4-5:2009 Section 6.3.3	$k_{(3)}$	[-]	2,0						
Partial safety factors <sup>1)</sup>	$\gamma_{Mcp}$	[-]	1,5						
<b>Concrete edge failure</b>									
Effective length of anchor	$l_f$	[mm]	60	95	100	112	125	144	200
Calculation diameter	d		10	12	14		18		25
Partial safety factor <sup>1)</sup>	$\gamma_{Mc}$	[-]	1,5						
<sup>1)</sup> In absence of other national regulations									
fischer Highbond-Anchor FHB II								<b>Annex C 3</b>	
<b>Leistungen</b> Charakteristische Werte für statische oder quasi-statische Querkzugbelastung von fischer Highbond- Ankern FHB II – A L (ungerissener oder gerissener Beton)									

<b>Table C4: Characteristic values under static or quasi-static shear load for fischer Highbond-Anchor FHB II – A S (uncracked and cracked concrete)</b>								
Size FHB II – A S		M10x		M12x	M16x	M20x	M24x	
		60	75	75	95	170	170	
<b>Bearing capacity under tensile load, steel failure</b>								
<b>Without lever arm</b>								
Characteristic resistance	Steel, zinc plated	$V_{Rk,s}$	[kN]	19,7	27,3	50,8	80,3	114,2
	Stainless steel A4			24,1	33,7	62,7	97,9	124,5
	High corrosion resistant steel C			24,1	33,7	62,7	97,9	141
<b>With lever arm</b>								
Characteristic bending moment	Steel, zinc plated	$M^0_{Rk,s}$	[Nm]	62	105	266	519	896
	Stainless steel A4 and			62	105	266	519	896
	High corrosion resistant steel C							
<b>Partial safety factors<sup>1)</sup></b>								
Partial safety factor		$\gamma_{Ms,V}$	[-]	1,25				
Ductility factor acc. to CEN/TS 1992-4-5:2009 Section 6.3.2.1		$k_2$	[-]	1,0				
<b>Concrete pryout failure</b>								
Factor k acc. TR029 Section 5.2.3.3 or $k_3$ acc. CEN/TS 1992-4-5:2009 Section 6.3.3		$k_{(3)}$	[-]	2,0				
Partial safety factor <sup>1)</sup>		$\gamma_{Mcp}$	[-]	1,5				
<b>Concrete edge failure</b>								
Effective length of anchor		$l_f$	[mm]	60	75	95	170	
Calculation diameter		d		10	12	16	25	
Partial safety factor <sup>1)</sup>		$\gamma_{Mc}$	[-]	1,5				
<sup>1)</sup> In absence of other national regulations								
fischer Highbond-Anchor FHB II						<b>Annex C 4</b>		
<b>Performances</b> Characteristic values under static or quasi-static shear load for fischer Highbond-Anchor FHB II – A S (uncracked and cracked concrete)								

<b>Table C5: Displacement for fischer Highbond-Anchor FHB II – A L</b>									
<b>Size FHB II – A L</b>	<b>M8x 60</b>	<b>M10x 95</b>	<b>M12x</b>		<b>M16x</b>			<b>M20x 210</b>	<b>M24x 210</b>
			<b>100</b>	<b>120</b>	<b>125</b>	<b>145</b>	<b>160</b>		
<b>Displacement under tension load</b>									
<b>Cracked concrete</b>									
Tension load [kN]	6,6	15,9	17,1	22,5	24,0	30,0	34,7	52,2	52,2
$\delta_{N0}$ [mm]	0,8				0,6				
$\delta_{N\infty}$	1,7								
<b>Uncracked concrete</b>									
Tension load [kN]	9,3	22,3	24,0	31,6	33,6	42,0	48,7	73,2	73,2
$\delta_{N0}$ [mm]	0,2	0,4					0,6		
$\delta_{N\infty}$	1,7								
<b>Displacement under shear load</b>									
<b>Uncracked or cracked concrete</b>									
<b>Steel zinc plated</b>									
Shear load [kN]	7,8	11,9	17,3		32,2			50,2	72,5
$\delta_{V0}$ [mm]	1,2		1,3			3,5			
$\delta_{V\infty}$	1,8		2,0			5,3			
<b>Stainless steel A4</b>									
Shear load [kN]	8,7	13,3	19,3		35,8			55,9	80,6
$\delta_{V0}$ [mm]	1,0		1,1		2,2			3,5	
$\delta_{V\infty}$	1,5		1,7		3,3			5,3	
<b>High corrosion resistant steel C</b>									
Shear load [kN]	8,7	13,3	19,3		35,8			55,9	80,6
$\delta_{V0}$ [mm]	1,2		1,3		2,4			3,7	5,0
$\delta_{V\infty}$	1,8		2,0		3,6			5,6	7,5
fischer Highbond-Anchor FHB II								<b>Annex C 5</b>	
<b>Performances</b> Displacement for fischer Highbond-Anchor FHB II – A L									

<b>Table C6: Displacement for fischer Highbond-Anchor FHB II – A S</b>						
Size FHB II – A S	M10x		M12x	M16x	M20x	M24x
	60	75	75	95	170	170
<b>Displacement under tension load</b>						
<b>Cracked concrete</b>						
Tension load [kN]	6,6	11,1	15,9	38,0		
$\delta_{N0}$ [mm]	0,8	0,3	0,4	0,6		
$\delta_{N\infty}$	1,7					
<b>Uncracked concrete</b>						
Tension load [kN]	9,3	15,6	22,3	53,3		
$\delta_{N0}$ [mm]	0,2				0,5	
$\delta_{N\infty}$	1,7					
<b>Displacement under shear load</b>						
<b>Cracked or uncracked concrete</b>						
<b>Steel zinc plated</b>						
Shear load [kN]	11,3	12,7	29,0	45,9	65,3	
$\delta_{V0}$ [mm]	1,2	1,5	2,8			
$\delta_{V\infty}$	1,8	2,3	4,2			
<b>Stainless steel A4</b>						
Shear load [kN]	13,8	19,3	35,8	55,9	71,1	
$\delta_{V0}$ [mm]	1,0	1,1	2,2	3,5		
$\delta_{V\infty}$	1,5	1,7	3,3	5,3		
<b>High corrosion resistant steel C</b>						
Shear load [kN]	13,8	19,3	35,8	55,9	80,6	
$\delta_{V0}$ [mm]	1,2	1,3	2,4	3,7	5,0	
$\delta_{V\infty}$	1,8	2,0	3,6	5,6	7,5	
fischer Highbond-Anchor FHB II					<b>Annex C 6</b>	
<b>Performances</b> Displacement for fischer Highbond-Anchor FHB II – A S						