

RoHS compliant

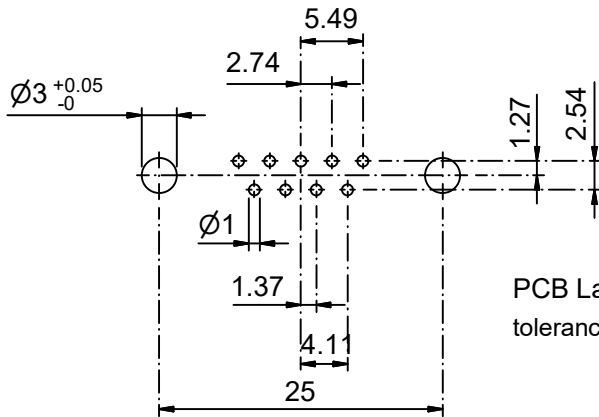
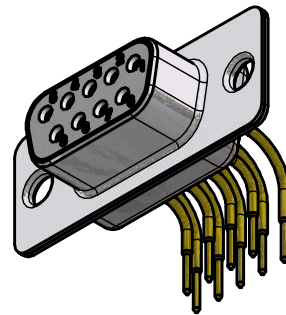
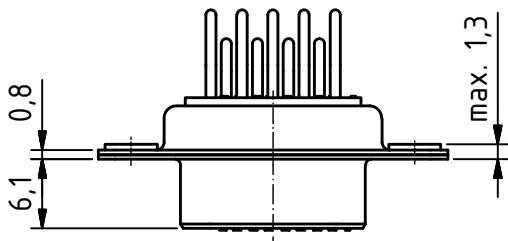
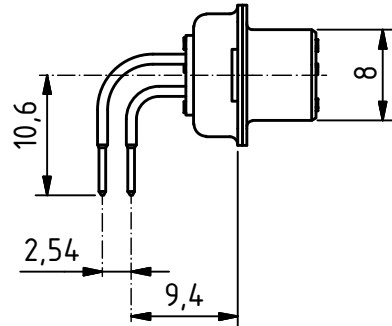
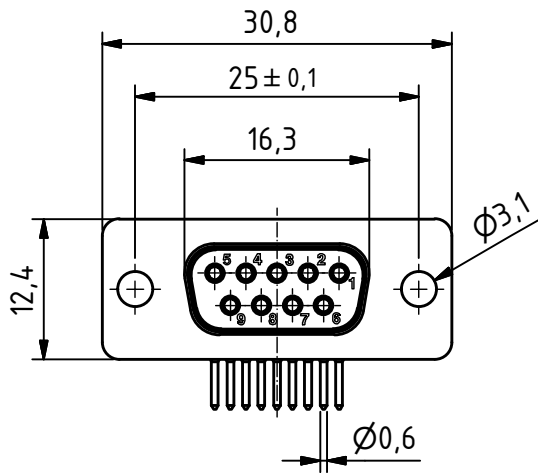

PCB Layout  
tolerances +/-0.1

Product is  
suitable for  
Wave Solder  
Process

**MATERIALS**

- Insulator: Thermoplastic UL 94-V-0 white
- Contact: Machined / Copper alloy
- Contact finish: Quality class 2
- Shell: steel tin plated

**CHARAKTERISTICS**

- Working voltage: 125V
- Current rating: 7.5A
- Contact resistance: max. 10mΩ - DIN41652
- Insulation resistance: >5GΩ
- Temperature range: -55° to +125°C

General tolerances (Deltron standard)			
size in mm			
> 0.5	> 3	> 6	> 30
up to 3	up to 6	up to 30	up to 120
tolerances			
±0.1	±0.2	±0.2	±0.3

	All dimensions in mm	Rev. a) 13.05.2010 mr	Rev.	Rev.	DE002162		
		Rev.	Rev.	Rev.	part no.		
DTS09SYC/2				1.5:1 scale	drawn	09.03.2010	mr
					checked		
				approved			
				Industrie Neuhof 8c CH-3422 Kirchberg www.d-sub.swiss		K050064 a	
						drawing no.	