



DESCRIPTION

The MPQ2178 is a monolithic, step-down, switch-mode converter with built-in internal power MOSFETs. It achieves 2A of continuous output current across a 2.5V to 6V input voltage range, with excellent load and line regulation. The output voltage (V_{OUT}) can be regulated to as low as 0.6V.

The constant-on-time (COT) control scheme provides fast transient response and eases loop stabilization. Fault protections include cycle-by-cycle current limiting and thermal shutdown.

The MPQ2178 is ideal for a wide range of applications including automotive infotainment systems, clusters and telematics.

The MPQ2178 requires a minimal number of readily available, standard external components, and is available in an ultra-small QFN-8 (1.5mmx2mm) package.

FEATURES

- **Designed for Automotive Applications:**
 - Wide 2.5V to 6V Operating Input Voltage Range
 - Up to 2A Output Current
 - 1% FB Accuracy
 - Junction Temperature Operation from -40°C to +150°C
- **High Performance for Improved Thermals:**
 - 70mΩ and 40mΩ Internal Power MOSFETs
- **Optimized for EMC and EMI Reduction:**
 - 2.4MHz Switching Frequency
 - FCCM across Full Load Range
 - MeshConnect™ Flip-Chip Package
- **Optimized for Board Size and BOM:**
 - Built-in Internal Power MOSFETs
 - Integrated Compensation Network

FEATURES (continued)

- Fixed Output Options ⁽¹⁾: 0.7V, 0.75V, 0.8V, 0.85V, 0.88V, 0.9V, 1.05V, 1V, 1.1V, 1.2V, 1.25V, 1.5V, 1.8V, 2.5V, 2.8V, and 3.3V
- **Additional Features:**
 - EN for Power Sequencing
 - Power Good (PG)
 - 100% Duty Cycle
 - External Soft Start (SS) Control
 - Output Discharge
 - Output Over-Voltage Protection
 - Short-Circuit Protection (SCP) with Hiccup Mode
 - Available in a Compact QFN-8 (1.5mmx2mm) Package
 - Available in a Wettable Flank Package
 - Available in AEC-Q100 Grade 1
- **Functional Safety System Design Capable**
 - MPSafe™ QM Documentation Available



Note:

1) See the Ordering Information section on page 3 for additional fixed output options.

APPLICATIONS

- Automotive Infotainment
- Camera Modules
- Key Fobs
- Automotive Clusters
- Automotive Telematics
- Industrial Supplies
- Battery-Powered Devices

All MPS parts are lead-free, halogen-free, and adhere to the RoHS directive. For MPS green status, please visit the MPS website under Quality Assurance. "MPS", the MPS logo, and "Simple, Easy Solutions" are trademarks of Monolithic Power Systems, Inc. or its subsidiaries.

TYPICAL APPLICATION

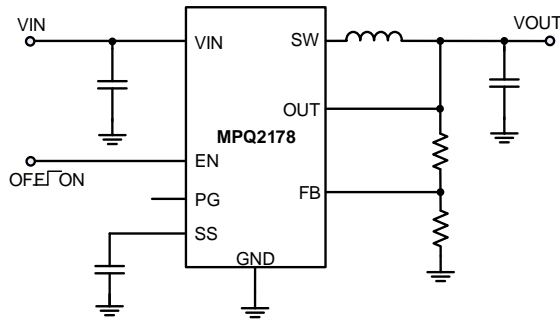

Adjustable Output Version

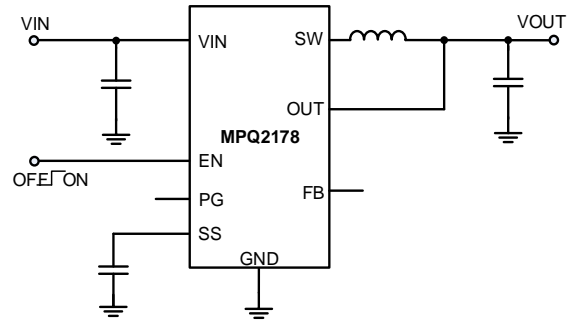

Fixed Output Version

Efficiency vs. Load Current vs. Power Loss

$V_{OUT} = 1.2V$, $L = 1\mu H$,
(XEL4020-102MEB, DCR = 13.25m Ω)

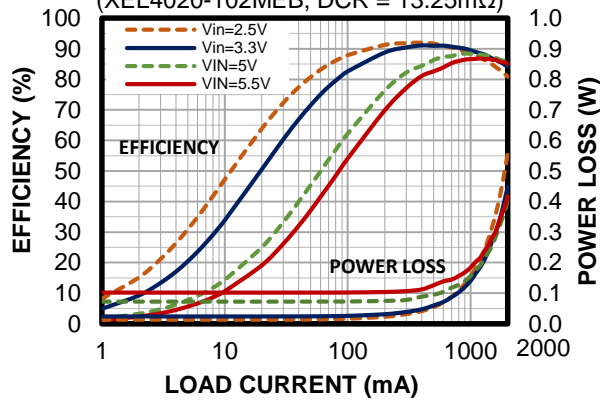

ORDERING INFORMATION

Part Number* (2)	Output Voltage	Package	Top Marking	MSL Rating**
MPQ2178GQHE***	Adjustable	QFN-8 (1.5mmx2mm)	See Below	1
MPQ2178GQHE-AEC1***	Adjustable			
MPQ2178GQHE-8-AEC1***	Fixed 0.8V			
MPQ2178GQHE-11-AEC1***	Fixed 1.1V			
MPQ2178GQHE-12-AEC1***	Fixed 1.2V			
MPQ2178GQHE-125-AEC1***	Fixed 1.25V			
MPQ2178GQHE-18-AEC1***	Fixed 1.8V			

* For Tape & Reel, add suffix -Z (e.g. MPQ2178GQHE-AEC1-Z).

** Moisture Sensitivity Level Rating

*** Wettable flank

Note:

2) Contact an MPS FAE for more details on additional fixed output options.

TOP MARKING

—
KU
LL

KU: Product code of MPQ2178GQHE or MPQ2178GQHE-AEC1
 LL: Lot number

—
NP
LL

NP: Product code of MPQ2178GQHE-8-AEC1
 LL: Lot number

—
NQ
LL

NQ: Product code of MPQ2178GQHE-11-AEC1
 LL: Lot number

—
LT
LL

LT: Product code of MPQ2178GQHE-12-AEC1
 LL: Lot number

—
NR
LL

NR: Product code of MPQ2178GQHE-125-AEC1
 LL: Lot number

—
LJ
LL

LJ: Product code of MPQ2178GQHE-18-AEC1
 LL: Lot number

PACKAGE REFERENCE

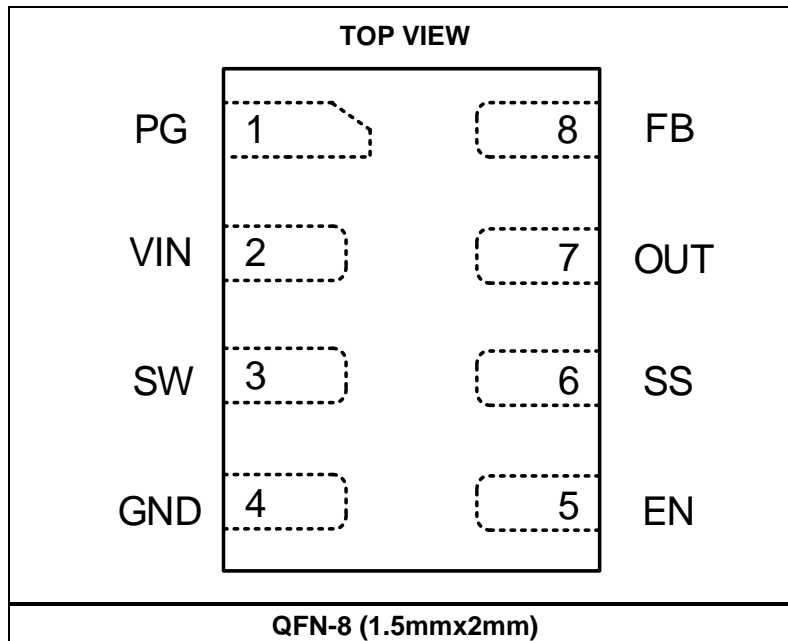

PIN FUNCTIONS

Pin #	Name	Description
1	PG	Power good indicator. The output of this pin is an open drain. Connect PG to a voltage source using an external resistor. PG is pulled high when V_{FB} exceeds 90% of V_{REF} ; PG is pulled low to GND if V_{FB} drops below 85% of V_{REF} . Float this pin if not used.
2	VIN	Supply voltage. The MPQ2178 operates from a 2.5V to 6V input. A decoupling capacitor is required to prevent large voltage spikes from appearing at the input.
3	SW	Output switching node. SW is the drain of the internal, high-side P-channel MOSFET. Connect the inductor to SW to complete the converter.
4	GND	Ground.
5	EN	Enable control. Pull EN below the falling threshold (0.65V) to shut down the chip. Pull EN above the rising threshold (0.9V) to enable the chip. There is an internal 2M Ω resistor from EN to ground.
6	SS	Soft start. Connect a capacitor across SS and GND to set the soft-start time (t_{SS}) to avoid start-up inrush current. The minimum recommended soft-start capacitance (C_{SS}) is 1nF.
7	OUT	Output voltage. The OUT pin is the output voltage (V_{OUT}) for the power rail and input sense. Connect the load to this pin. An output capacitor is required to decrease the output voltage ripple.
8	FB	Feedback. An external resistor divider from the output to GND, tapped to the FB pin. The FB voltage (V_{FB}) is compared to the internal 0.6V reference voltage (V_{REF}) to set the regulation voltage. For the fixed output version of the MPQ2178, this pin can be floated.

ABSOLUTE MAXIMUM RATINGS ⁽³⁾

SW	-0.3V (-1.5V for <10ns)
..... to +6.5V (+7.5V for <10ns)	
All other pins	-0.3V to +6.5V
Junction temperature	150°C
Lead temperature	260°C
Continuous power dissipation ($T_A = 25^\circ\text{C}$) ⁽⁴⁾ ⁽⁶⁾	2.2W
Storage temperature	-65°C to +150°C

ESD Ratings

Human body model (HBM)	$\pm 2000\text{V}$
Charged device model (CDM)	$\pm 750\text{V}$

Recommended Operating Conditions

Supply voltage (V_{IN})	2.5V to 6V
Output voltage (V_{OUT})	0.6V to $V_{IN} - 0.5\text{V}$
Operating junction temp (T_J)	-40°C to +150°C

Thermal Resistance

 θ_{JA} θ_{JC}

QFN-8 (1.5mmx2mm)		
JESD51-7 ⁽⁵⁾	130.....	25..... °C/W
EVQ2178-QH-00A ⁽⁶⁾	59.....	14..... °C/W

Notes:

- Exceeding these ratings may damage the device.
- The maximum allowable power dissipation is a function of the maximum junction temperature T_J (MAX), the junction-to-ambient thermal resistance θ_{JA} , and the ambient temperature T_A . The maximum allowable continuous power dissipation at any ambient temperature is calculated by P_D (MAX) = $(T_J$ (MAX) - T_A) / θ_{JA} . Exceeding the maximum allowable power dissipation can cause excessive die temperature, and the regulator may go into thermal shutdown. Internal thermal shutdown circuitry protects the device from permanent damage.
- Measured on JESD51-7, 4-layer PCB. The values given in this table are only valid for comparison with other packages and cannot be used for design purposes. These values were calculated in accordance with JESD51-7, and simulated on a specified JEDEC board. They do not represent the performance obtained in an actual application.
- Measured on EVQ2178-QH-00A, 6.3cmx6.3cm, 2oz per layer, 4-layer PCB.

ELECTRICAL CHARACTERISTICS

$V_{IN} = 3.6V$, $T_J = -40^{\circ}C$ to $+150^{\circ}C$, typical value tested at $T_J = 25^{\circ}C$, unless otherwise noted.

Parameter	Symbol	Condition	Min	Typ	Max	Units
Input voltage (V_{IN}) range			2.5		6	V
Under-voltage lockout (UVLO) rising threshold				2.3	2.45	V
UVLO threshold hysteresis				200		mV
Shutdown supply current		$V_{EN} = 0V$, $T_J = 25^{\circ}C$		0.01	1	μA
		$V_{EN} = 0V$, $T_J = -40^{\circ}C$ to $+125^{\circ}C$ ⁽⁸⁾			3	μA
		$V_{EN} = 0V$, $T_J = -40^{\circ}C$ to $+150^{\circ}C$			20	μA
Quiescent supply current		$V_{EN} = 2V$, $V_{FB} = 0.63V$, $V_{IN} = 3.6V$, $T_J = 25^{\circ}C$		460	650	μA
Feedback voltage	V_{FB}	$T_J = 25^{\circ}C$	594	600	606	mV
		$T_J = -40^{\circ}C$ to $+150^{\circ}C$	591	600	609	
Feedback current	I_{FB}	$V_{FB} = 0.63V$, adjustable output		50	100	nA
		$V_{FB} = 0.63V$, 0.8V fixed output		2	5	μA
		$V_{FB} = 0.63V$, 1.1V fixed output		2	4	μA
		$V_{FB} = 0.63V$, 1.2V fixed output		3	8	μA
		$V_{FB} = 0.63V$, 1.25V fixed output		2.5	7	μA
		$V_{FB} = 0.63V$, 1.8V fixed output		5	10	μA
Output regulation voltage (fixed output version)	V_{OUT_REG}	0.8V fixed output	0.792	0.8	0.808	V
		1.1V fixed output	1.089	1.1	1.111	V
		1.2V fixed output	1.176	1.2	1.224	V
		1.25V fixed output	1.225	1.25	1.275	V
		1.8V fixed output	1.764	1.8	1.836	V
P-channel MOSFET on resistance	$R_{DS(ON)_P}$	$V_{IN} = 5V$		70	100	m Ω
N-channel MOSFET on resistance	$R_{DS(ON)_N}$	$V_{IN} = 5V$		40	60	m Ω
Switch leakage		$V_{EN} = 0V$, $V_{IN} = 6V$, $V_{SW} = 0V$ or $6V$, $T_J = 25^{\circ}C$		0	1	μA
		$V_{EN} = 0V$, $V_{IN} = 6V$, $V_{SW} = 0V$ or $6V$, $T_J = -40^{\circ}C$ to $+125^{\circ}C$ ⁽⁸⁾			30	μA
Switching frequency	f_{SW}	$V_{IN} = 5V$, $V_{OUT} = 1.2V$, CCM	2000	2400	2640	kHz
Minimum on time ⁽⁸⁾	t_{MIN_ON}	$V_{IN} = 5V$		50		ns
Minimum off time ⁽⁸⁾	t_{MIN_OFF}	$V_{IN} = 5V$		80		ns
P-channel MOSFET peak current limit			2.5	3.5	4.5	A
N-channel MOSFET valley current limit			1	2	3	A
Soft-start current	I_{SS_ON}	Adjustable output and 1.1V, 1.2V, 1.8V fixed output	1.5	3	4.5	μA
		0.8V, 1.25V fixed output	12	16	20	μA
Maximum duty cycle				100		%
Power good (PG) UV rising threshold		FB rising edge	87	90	93	%

ELECTRICAL CHARACTERISTICS (continued)
 $V_{IN} = 3.6V$, $T_J = -40^{\circ}C$ to $+150^{\circ}C$, typical value tested at $T_J = 25^{\circ}C$, unless otherwise noted.

Parameter	Symbol	Condition	Min	Typ	Max	Units
PG sink current capability	V_{PG-L}	Sink 1mA			0.4	V
PG logic high voltage	V_{PG-H}	$V_{IN} = 5V$, $V_{FB} = 0.6V$	4.9			V
Self-bias PG ⁽⁷⁾					0.7	V
PG leakage current/logic high		5V logic high			100	nA
EN turn-on delay		EN on to SW active		100		μs
EN turn-off delay		EN off to when switching stops		30		μs
EN input logic low voltage			0.4	0.65		V
EN input logic high voltage				0.9	1.2	V
EN pull-down resistor				2		M Ω
Output discharge resistor	R_{DIS}	$V_{EN} = 0V$, $V_{OUT} = 1.2V$		150		Ω
EN input current		$V_{EN} = 2V$		1.2		μA
		$V_{EN} = 0V$		0		μA
Output over-voltage (OV) rising threshold	V_{OVP}		110	115	120	% V_{FB}
Output OV hysteresis	V_{OVP_HYS}			10		% V_{FB}
Output OV delay				2		μs
Low-side current limit		Current flow from SW to GND		1.2		A
Absolute V_{IN} over-voltage protection (OVP)		After V_{OUT} OVP is enabled		6.1		V
Absolute V_{IN} OVP hysteresis				160		mV
Thermal shutdown ⁽⁸⁾				170		$^{\circ}C$
Thermal shutdown hysteresis ⁽⁸⁾				20		$^{\circ}C$

Notes:

- 7) $V_{IN} = 0V$, $EN = 0V$, PG pulled up to 3V to 6V with a 100k Ω resistor.
 8) Guaranteed by design and bench characterization. Not tested in production.

TYPICAL CHARACTERISTICS

$V_{IN} = 3.6V$, $T_J = -40^{\circ}C$ to $+150^{\circ}C$, unless otherwise noted.

V_{IN} UVLO Threshold vs. Temperature

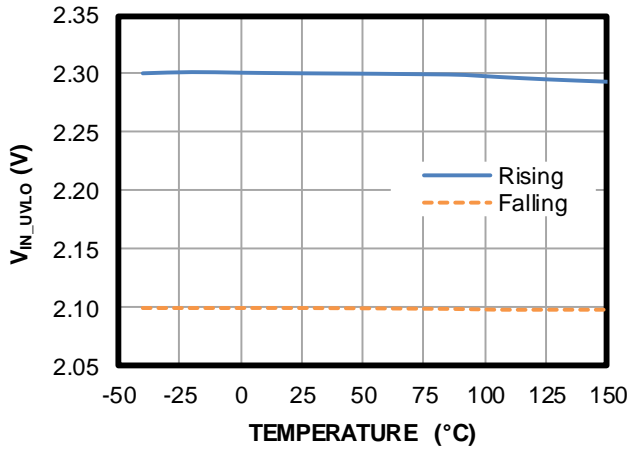

EN Rising and Falling Threshold vs. Temperature

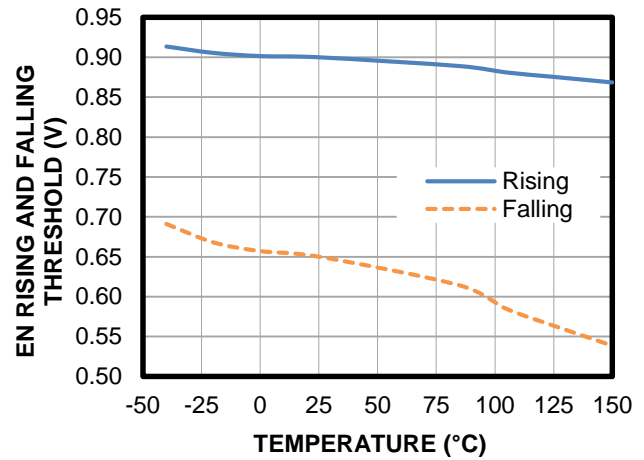

Shutdown Current vs. Temperature

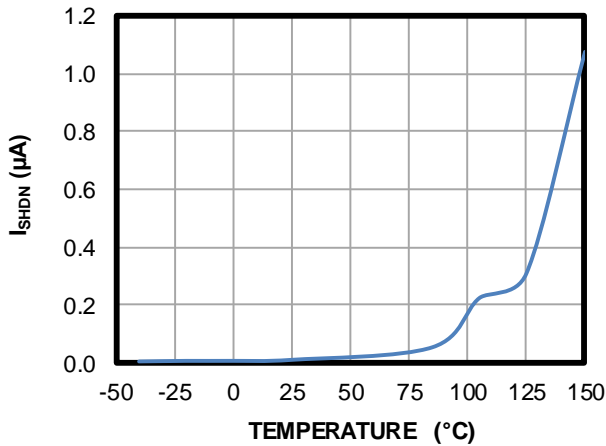

Quiescent Current vs. Temperature

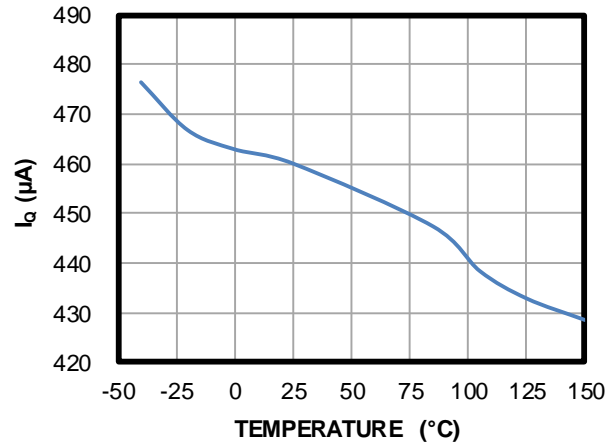

Feedback Voltage vs. Temperature

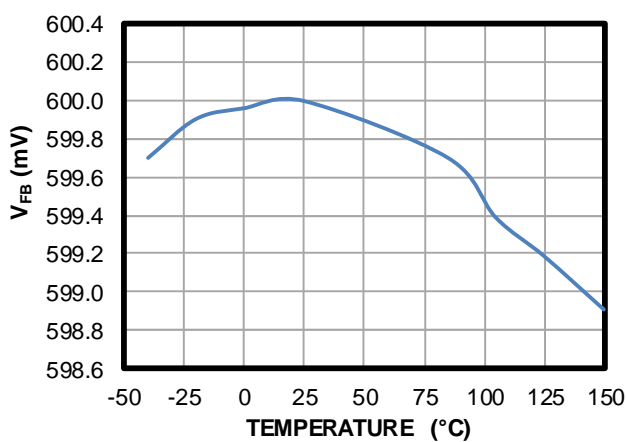

Switching Frequency vs. Temperature

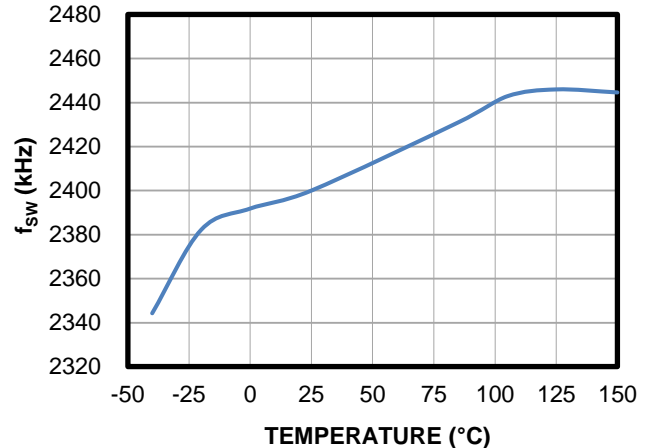

TYPICAL CHARACTERISTICS (continued)
 $V_{IN} = 3.6V$, $T_J = -40^{\circ}C$ to $+150^{\circ}C$, unless otherwise noted.

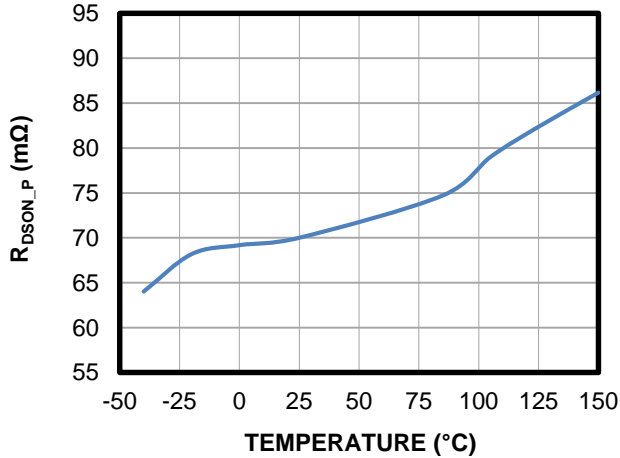
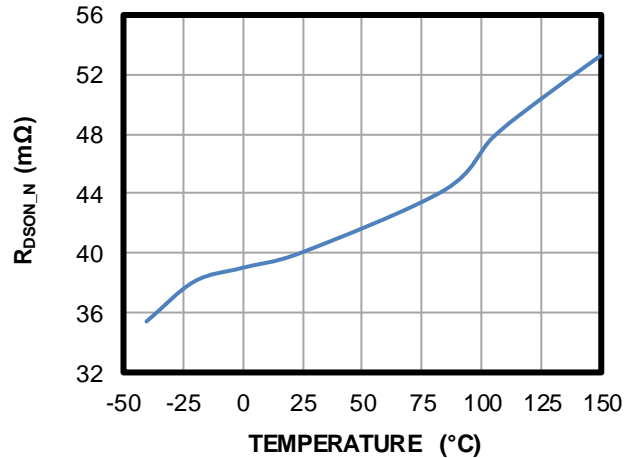
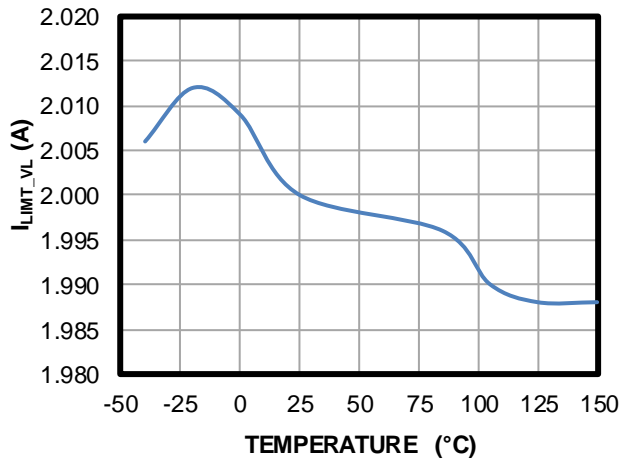
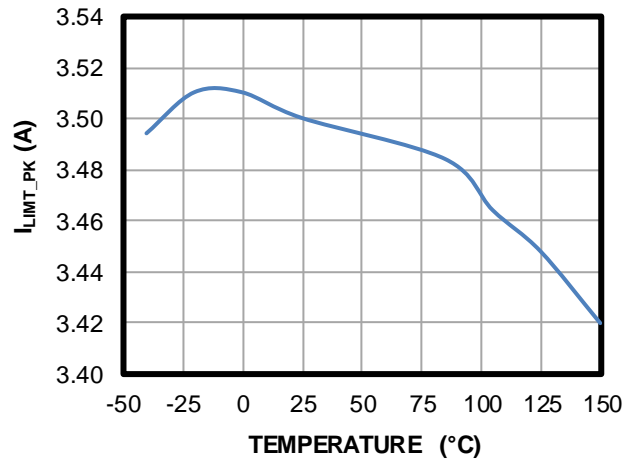
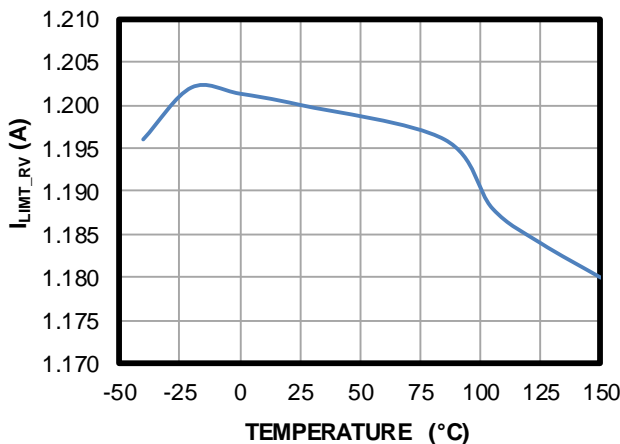
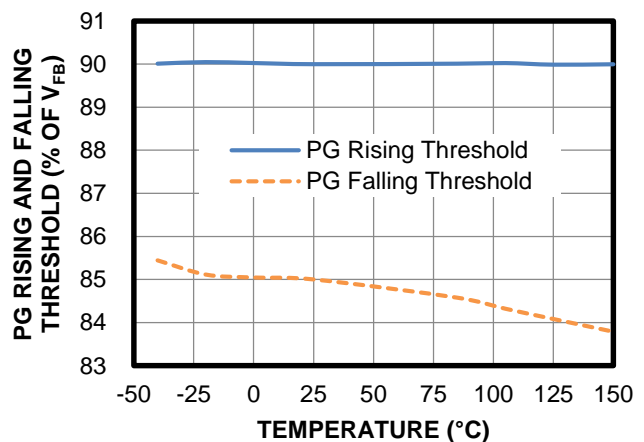
P-Channel MOSFET On Resistance vs. Temperature

N-Channel MOSFET On Resistance vs. Temperature

N-Channel MOSFET Valley Current Limit vs. Temperature

P-Channel MOSFET Peak Current Limit vs. Temperature

Low-Side Reverse Current Limit vs. Temperature

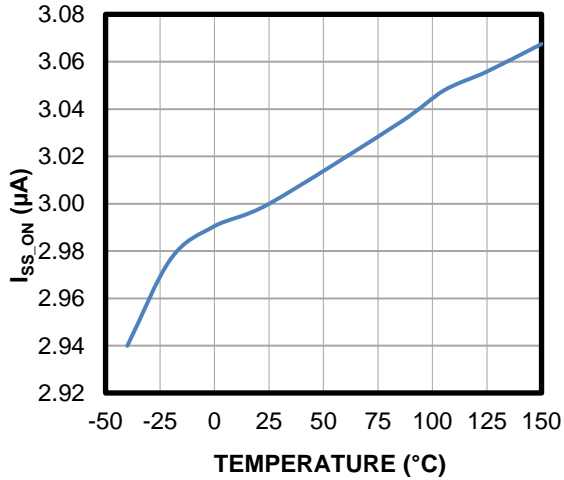
PG Rising and Falling Threshold vs. Temperature

TYPICAL CHARACTERISTICS (continued)

$V_{IN} = 3.6V$, $T_J = -40^{\circ}C$ to $+150^{\circ}C$, unless otherwise noted.

Soft-Start Current vs. Temperature

MPQ2178, MPQ2178-11, MPQ2178-12, and MPQ1278-18



Soft-Start Current vs. Temperature

MPQ2178-8, MPQ2178-125

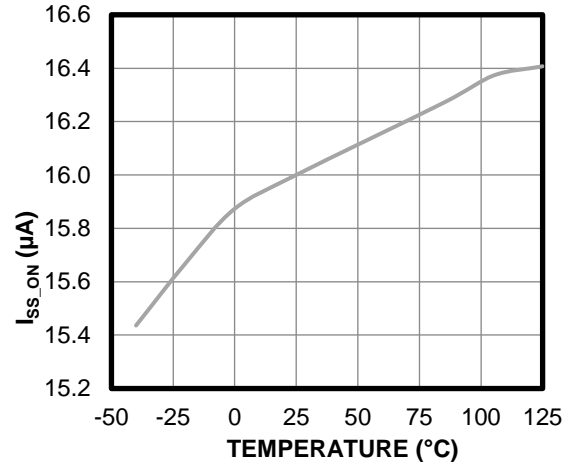

TYPICAL PERFORMANCE CHARACTERISTICS

$V_{IN} = 3.3V$, $V_{OUT} = 1.2V$, $L = 1\mu H$, $C_{OUT} = 22\mu F$, $T_A = 25^\circ C$, unless otherwise noted.

Efficiency vs. Load Current vs. Power Loss

$V_{OUT} = 1.2V$, $L = 1\mu H$,
(XEL4020-102MEB, DCR = 13.25m Ω)

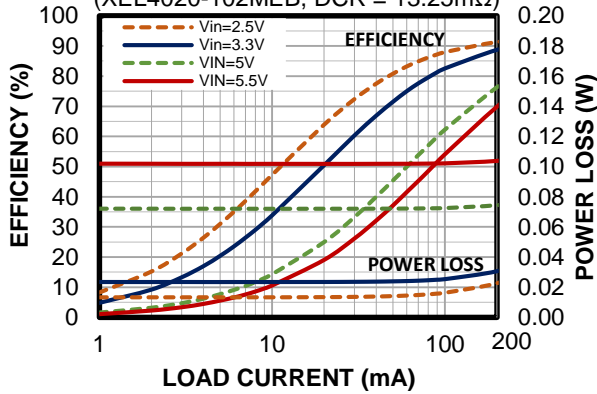

Efficiency vs. Load Current vs. Power Loss

$V_{OUT} = 1.2V$, $L = 1\mu H$,
(XEL4020-102MEB, DCR = 13.25m Ω)

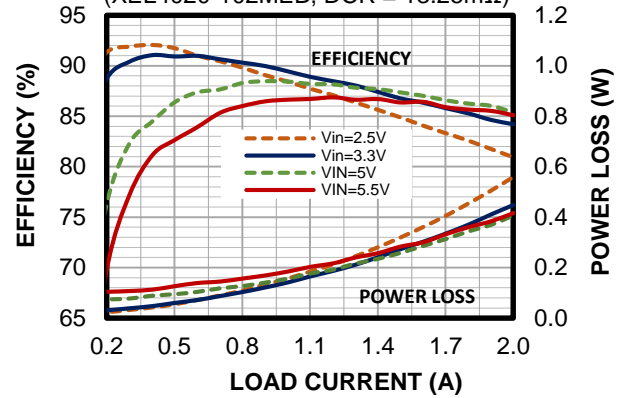

Efficiency vs. Load Current vs. Power Loss

$V_{OUT} = 1.8V$, $L = 1\mu H$,
(XEL4020-102MEB, DCR = 13.25m Ω)

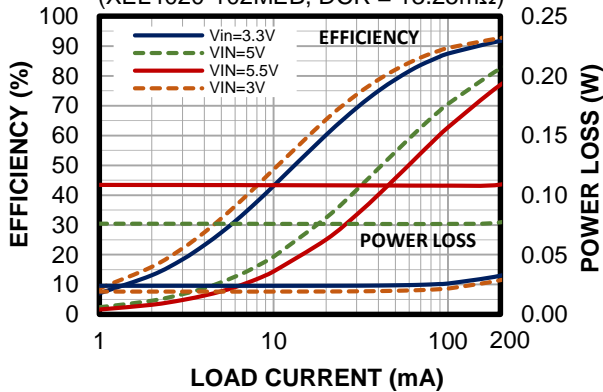

Efficiency vs. Load Current vs. Power Loss

$V_{OUT} = 1.8V$, $L = 1\mu H$,
(XEL4020-102MEB, DCR = 13.25m Ω)

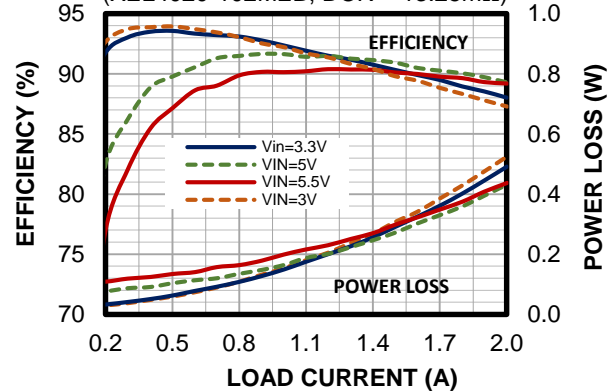

Load Regulation

$V_{OUT} = 1.2V$

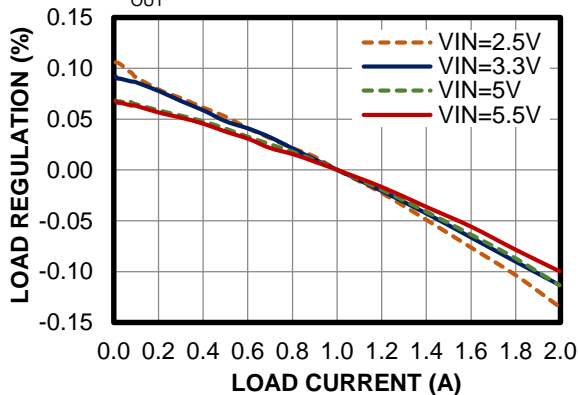

Load Regulation

$V_{OUT} = 1.8V$

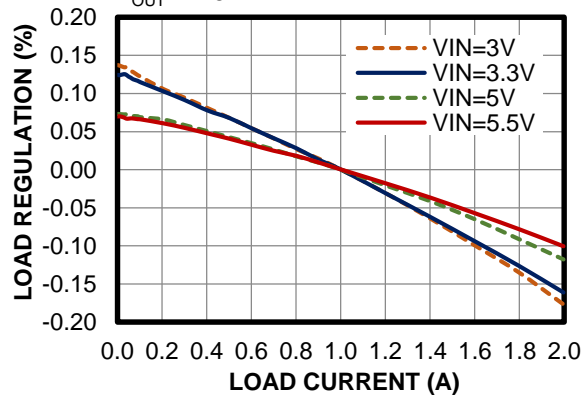

TYPICAL PERFORMANCE CHARACTERISTICS (continued)

$V_{IN} = 3.3V$, $V_{OUT} = 1.2V$, $L = 1\mu H$, $C_{OUT} = 22\mu F$, $T_A = 25^\circ C$, unless otherwise noted.

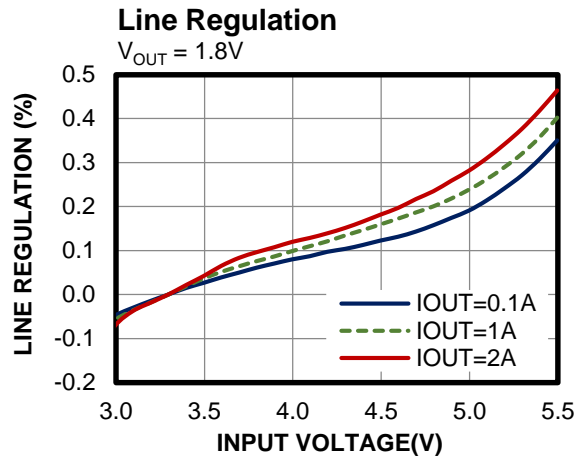
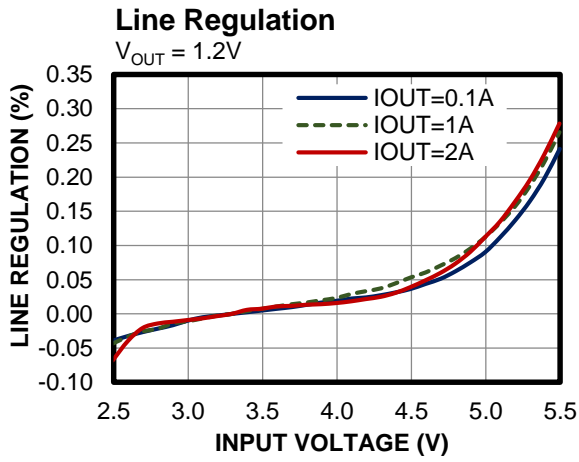

TYPICAL PERFORMANCE CHARACTERISTICS (continued)

$V_{IN} = 5.5V$, $V_{OUT} = 1.2V$, $L = 1\mu H$, $C_{OUT} = 22\mu F$, $I_o = 2A$, $T_A = 25^\circ C$, unless otherwise noted.

CISPR25 Class 5 Peak Conducted Emissions
150kHz to 108MHz

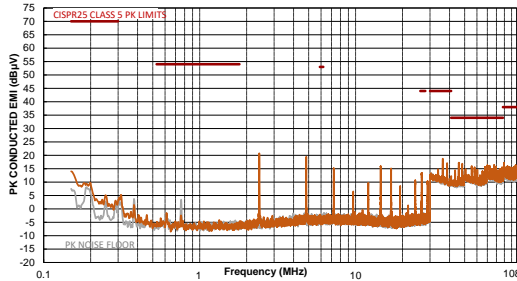

CISPR25 Class 5 Average Conducted Emissions
150kHz to 108MHz

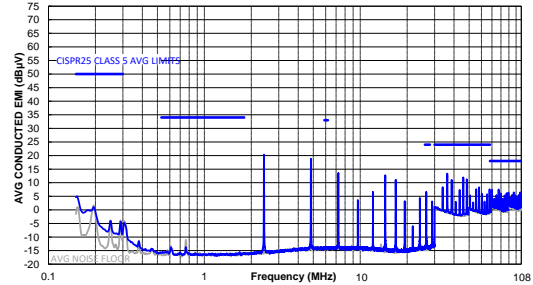

CISPR25 Class 5 Peak Radiated Emissions
150kHz to 30MHz

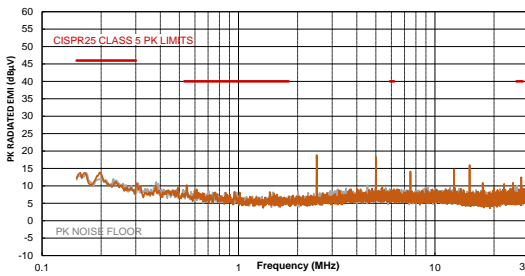

CISPR25 Class 5 Average Radiated Emissions
150kHz to 30MHz

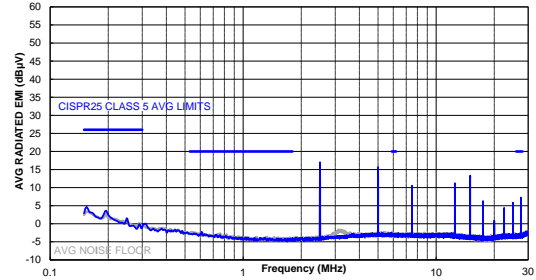

CISPR25 Class 5 Peak Radiated Emissions
Horizontal, 30MHz to 1GHz

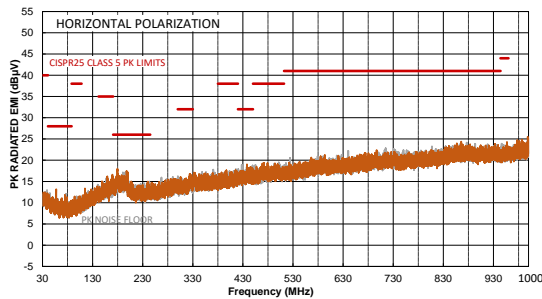

CISPR25 Class 5 Average Radiated Emissions
Horizontal, 30MHz to 1GHz

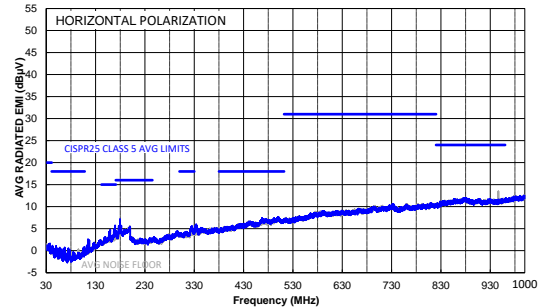

CISPR25 Class 5 Peak Radiated Emissions
Vertical, 30MHz to 1GHz

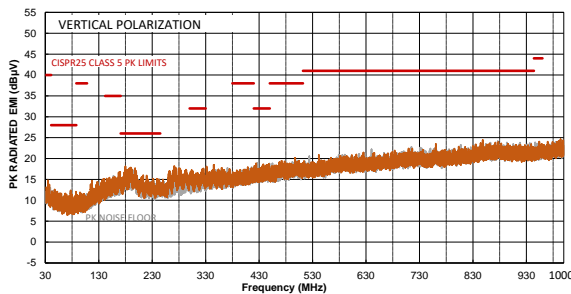

CISPR25 Class 5 Average Radiated Emissions
Vertical, 30MHz to 1GHz

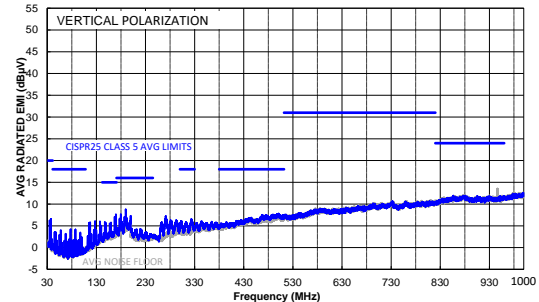

TYPICAL PERFORMANCE CHARACTERISTICS (continued)
 $V_{IN} = 3.3V$, $V_{OUT} = 1.2V$, $L = 1\mu H$, $C_{OUT} = 22\mu F$, $T_A = 25^\circ C$, unless otherwise noted.

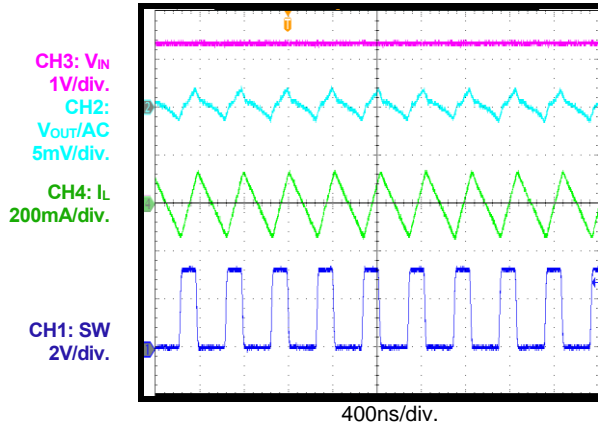
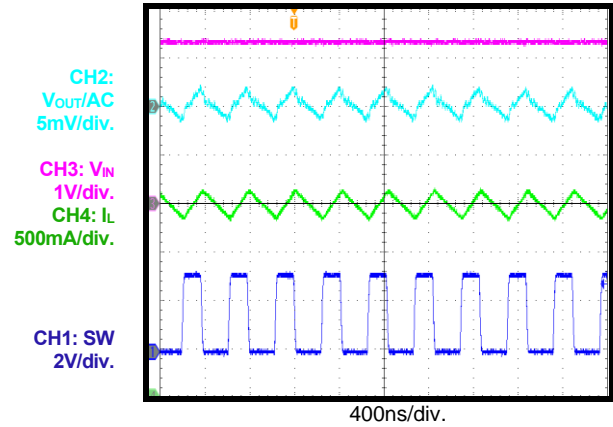
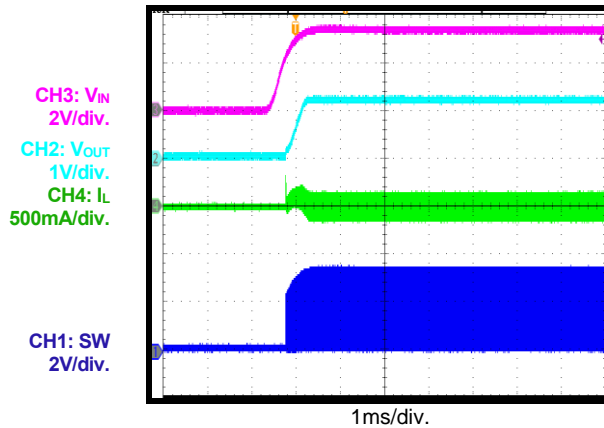
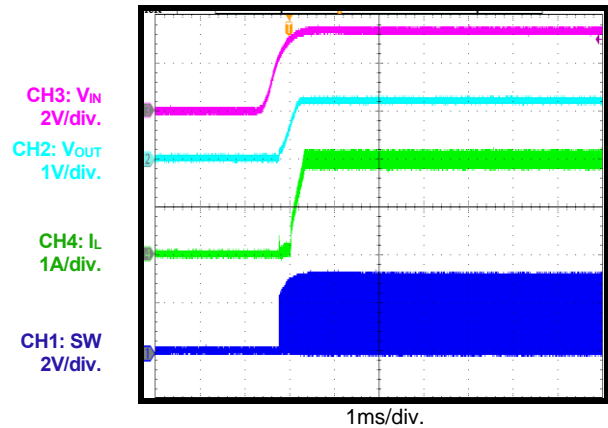
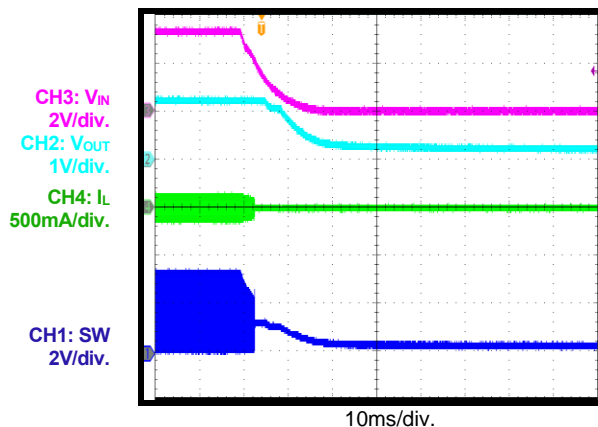
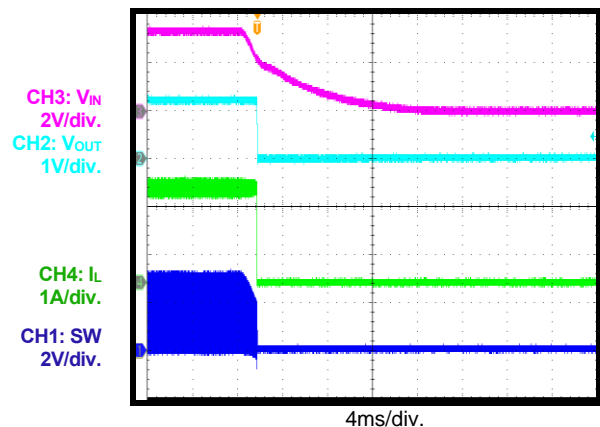
Steady State
 $I_{OUT} = 0A$

Steady State
 $I_{OUT} = 2A$

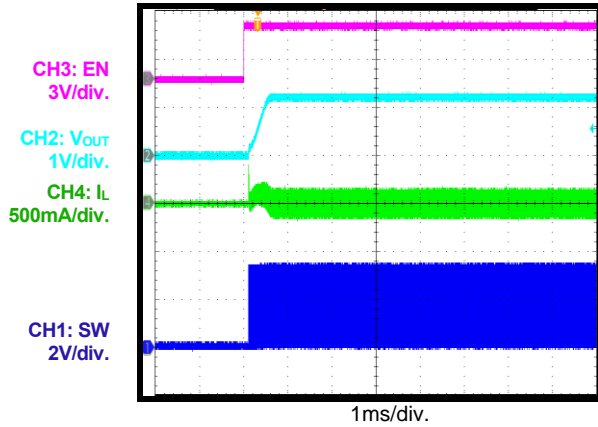
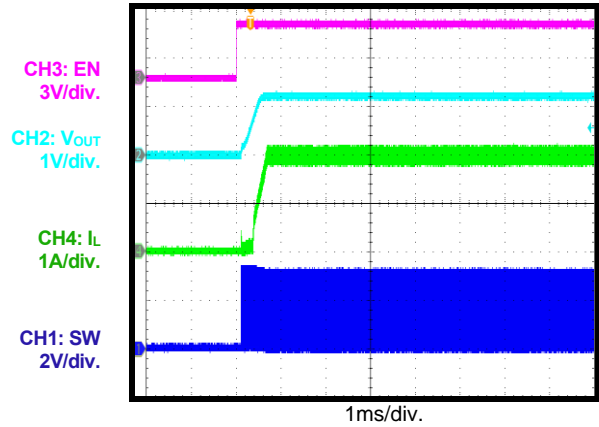
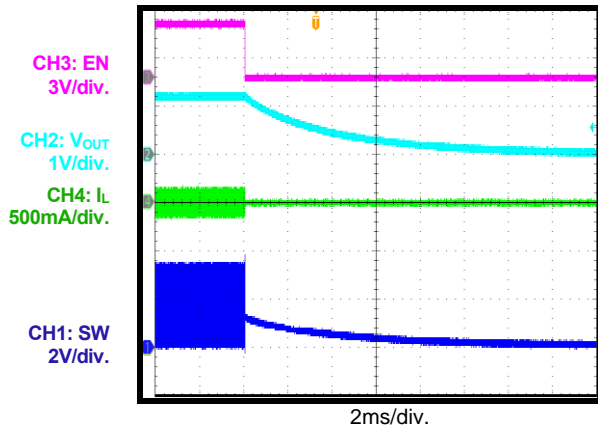
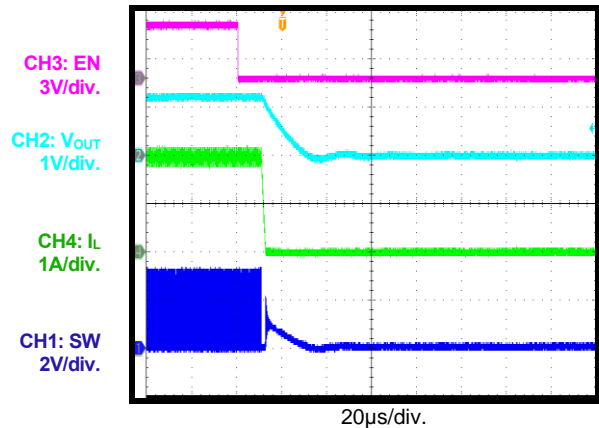
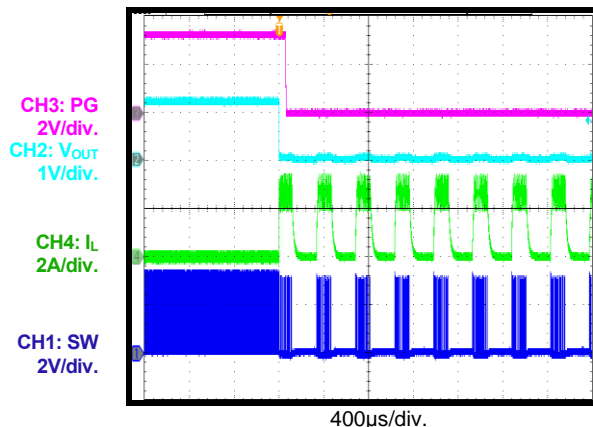
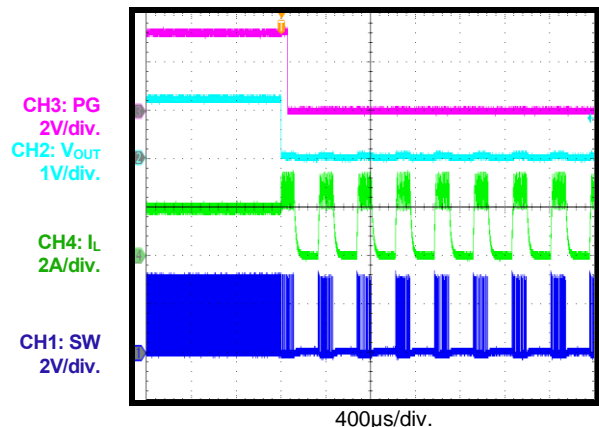
Start-Up through VIN
 $I_{OUT} = 0A$

Start-Up through VIN
 $I_{OUT} = 2A$

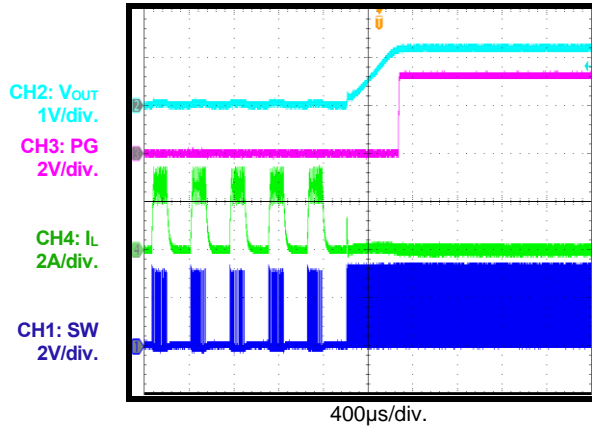
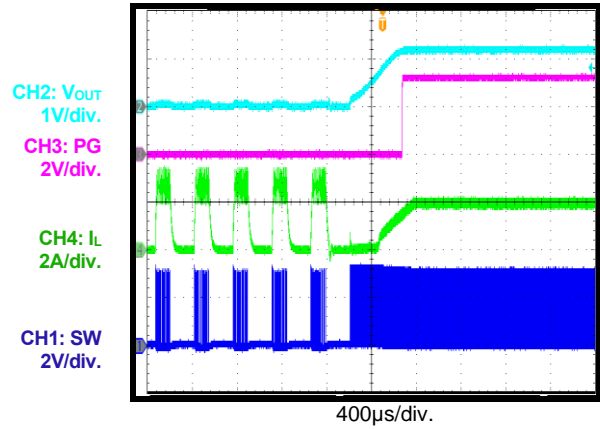
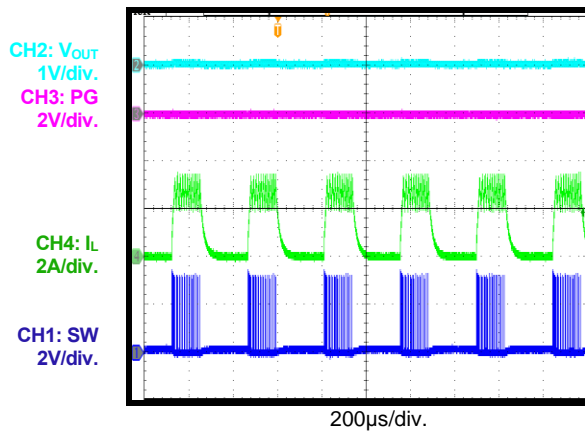
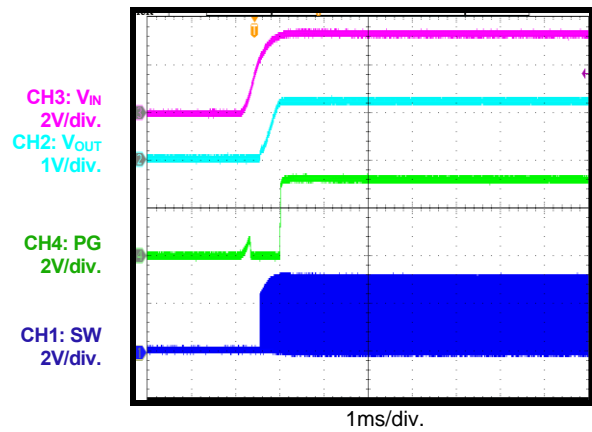
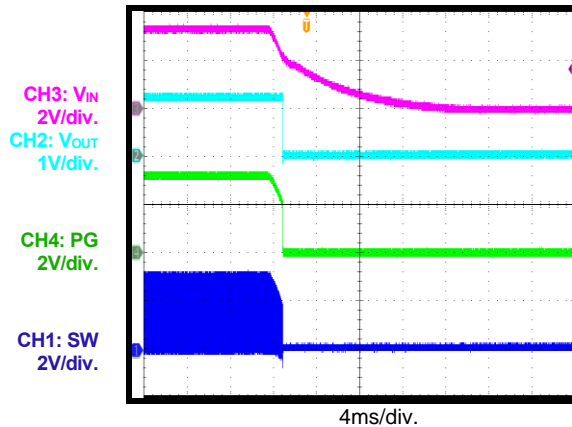
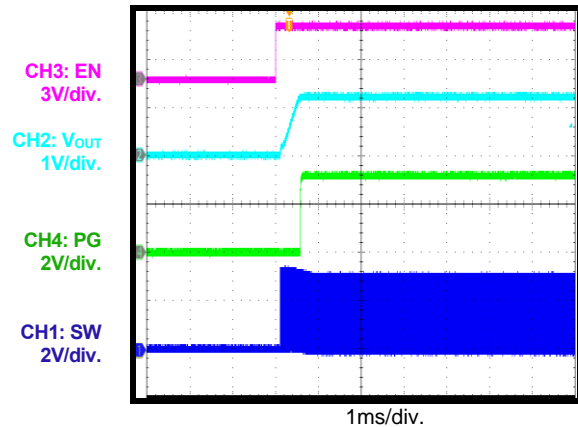
Shutdown through VIN
 $I_{OUT} = 0A$

Shutdown through VIN
 $I_{OUT} = 2A$

TYPICAL PERFORMANCE CHARACTERISTICS (continued)
 $V_{IN} = 3.3V$, $V_{OUT} = 1.2V$, $L = 1\mu H$, $C_{OUT} = 22\mu F$, $T_A = 25^\circ C$, unless otherwise noted.

Start-Up through EN
 $I_{OUT} = 0A$

Start-Up through EN
 $I_{OUT} = 2A$

Shutdown through EN
 $I_{OUT} = 0A$

Shutdown through EN
 $I_{OUT} = 2A$

SCP Entry
 $I_{OUT} = 0A$

SCP Entry
 $I_{OUT} = 2A$

TYPICAL PERFORMANCE CHARACTERISTICS (continued)
 $V_{IN} = 3.3V$, $V_{OUT} = 1.2V$, $L = 1\mu H$, $C_{OUT} = 22\mu F$, $T_A = 25^\circ C$, unless otherwise noted.

SCP Recovery
 $I_{OUT} = 0A$

SCP Recovery
 $I_{OUT} = 2A$

Short Circuit

PG in Start-Up through VIN
 $I_{OUT} = 2A$

PG in Shutdown through VIN
 $I_{OUT} = 2A$

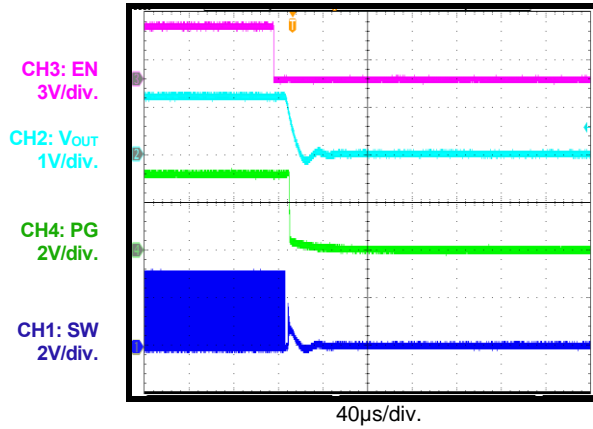
PG in Start-Up through EN
 $I_{OUT} = 2A$

TYPICAL PERFORMANCE CHARACTERISTICS *(continued)*

$V_{IN} = 3.3V$, $V_{OUT} = 1.2V$, $L = 1\mu H$, $C_{OUT} = 22\mu F$, $T_A = 25^\circ C$, unless otherwise noted.

PG in Shutdown through EN

$I_{OUT} = 2A$



Load Transient

$I_{OUT} = 1A$ to $2A$, $1A/\mu s$

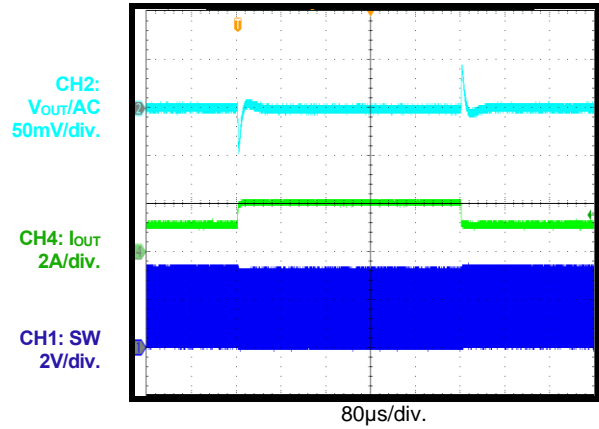

FUNCTIONAL BLOCK DIAGRAM

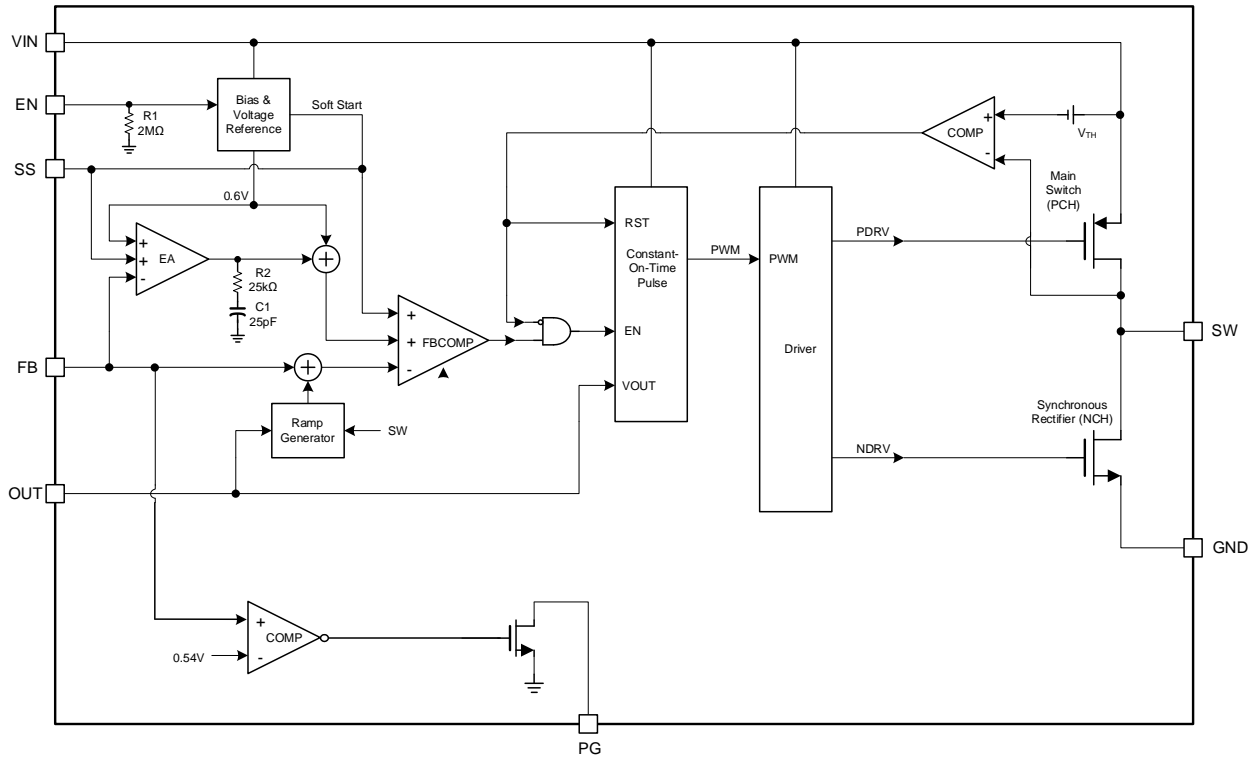

Figure 1: Functional Block Diagram of Adjustable Output Version

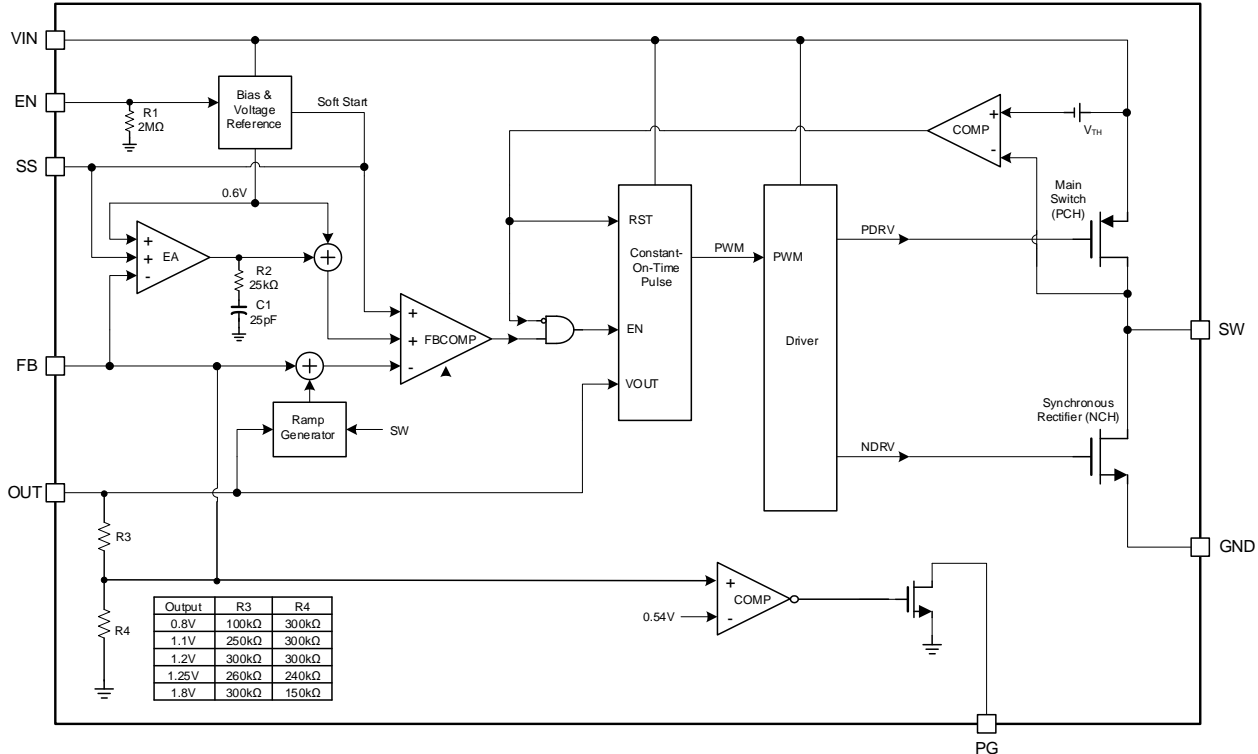

Figure 2: Functional Block Diagram of Fixed Output Version

OPERATION

The MPQ2178 uses constant-on-time (COT) control with input voltage (V_{IN}) feed-forward to stabilize the switching frequency (f_{SW}) across the full input range. It achieves 2A of continuous output current (I_{OUT}) across a 2.5V to 6V V_{IN} range, with excellent load and line regulation. The output voltage (V_{OUT}) can be regulated to as low as 0.6V for the adjustable output version. The MPQ2178 is capable of reaching 100% maximum duty cycle in low-dropout mode.

Constant-On-Time (COT) Control

Compared to fixed-frequency pulse-width modulation (PWM) control, COT control offers a simpler control loop and faster transient response. To prevent inductor current (I_L) runaway during load transient, the MPQ2178's MOSFET has a fixed minimum off time. When the low-side N-channel MOSFET (LS-FET) turns on, it remains on for at least $t_{MIN-OFF}$. Then the high-side P-channel MOSFET (HS-FET) turns on when the feedback voltage (V_{FB}) drops below the reference voltage (V_{REF}), which indicates an insufficient V_{OUT} . By using V_{IN} feed-forward, the MPQ2178 maintains a nearly constant f_{SW} across the input and load ranges. The switching pulse on time (t_{ON}) can be estimated with Equation (1):

$$t_{ON} = \frac{V_{OUT}}{V_{IN}} \times 400ns \quad (1)$$

In order to improve frequency stability and reduce the output voltage ripple, the MPQ2178 operates in forced continuous conduction mode (FCCM).

Enable

EN is a digital control pin that turns the MPQ2178 on and off. Pull EN above the EN rising threshold (0.9V) to turn the device on; pull EN below the falling threshold (0.65V) to turn it off. Leaving EN floating or pulling it down to ground disables the MPQ2178. There is an internal 2M Ω resistor from the EN pin to ground.

Output Discharge

When the device is disabled, the part automatically goes into output discharge mode and the internal discharge MOSFET provides a resistive discharge path from the OUT pin to

GND for the output capacitor (C_{OUT}). Output discharge mode can be blocked by adding an external capacitor between V_{OUT} and the OUT pin. See the Output Discharge Blocking section on page 21 for more details.

Soft Start (SS)

The MPQ2178 has an external SS pin that ramps up V_{OUT} at a controlled slew rate to avoid overshoot during start-up. The SS pin charge current is typically 3 μ A (for MPQ2178-8/125, 16 μ A).. The soft-start time (t_{SS}) is determined by the soft-start capacitor (C_{SS}), and can be calculated with Equation (2):

$$t_{SS} (ms) = \frac{C_{SS} (nF) \times 0.6V}{I_{SS} (\mu A)} \quad (2)$$

Where C_{SS} is the external soft-start capacitor, and I_{SS} is the internal 3 μ A/16 μ A SS charge current.

C_{SS} should be 1nF/5.3nF minimum.

The MPQ2178 offers a pre-biased start-up function. Once EN is enabled, the device starts up even if there is a pre-biased voltage on the output. Pre-biased start-up works regardless of whether output discharge mode is blocked.

Peak and Valley Current Limit

Both the HS-FET and LS-FET have current limit protection. When I_L reaches the HS-FET's peak current limit (typically 3.5A) during the HS-FET on time, the HS-FET immediately turns off to prevent the current from rising further, and the LS-FET turns on to discharge the energy. The HS-FET does not turn again until I_L drops below the valley current limit threshold (typically 2A). This current limit scheme helps prevent current runaway during overload and short circuit events.

Short-Circuit Protection (SCP) and Recovery

If V_{OUT} is shorted to ground and the MPQ2178 reaches its current limit, then the device enters short-circuit protection (SCP) and tries to recover with hiccup mode. The IC disables the output power stage, begins discharging the SS voltage (V_{SS}), and restarts with a full soft start once V_{SS} is fully discharged. This hiccup process repeats until the fault is removed.

Over-Voltage Protection (OVP)

The MPQ2178 monitors a resistor-divided feedback voltage to detect over-voltage (OV) conditions. If V_{FB} exceeds 115% of V_{REF} , the controller enters the dynamic regulation period. During this period, the LS-FET remains on until the LS-FET current reaches -1.2A; this process discharges V_{OUT} and tries to keep it within the normal range. If the OV condition still remains, the LS-FET turns on again after a 1.5 μ s delay. Once V_{FB} falls below 105% of V_{REF} , the MPQ2178 exits this regulation period. If the dynamic regulation period cannot prevent V_{OUT} from increasing and a 6.1V V_{IN} is detected, then over-voltage protection (OVP) occurs. The MPQ2178 stops switching until V_{IN} drops below 6V; once this occurs, the MPQ2178 resumes normal operation.

Power Good (PG) Indicator

The MPQ2178 has one power good (PG) output to indicate normal operation after soft start. PG is the open drain of an internal MOSFET, for which the maximum $R_{DS(ON)}$ must be below 400 Ω . PG can be connected to V_{IN} or an external voltage source through an external resistor (e.g. 100k Ω). After V_{IN} is applied, the MOSFET turns on and PG is pulled to GND before SS is ready. After V_{FB} reaches 90% of V_{REF} , PG is pulled high by the external voltage source. If V_{FB} drops to 85% of V_{REF} , the PG voltage (V_{PG}) is pulled to GND to indicate an output failure.

If V_{IN} and EN are not available and PG is pulled up by an external power supply, then PG will self-bias and assert. If a 100k Ω pull-up resistor is used, the voltage on the PG pin is less than 0.7V.

APPLICATION INFORMATION

Setting the Output Voltage

The external resistor divider sets V_{OUT} for the adjustable output version of the MPQ2178. Select the feedback resistor (R1) that reduces the V_{OUT} leakage current (typically between 10k Ω and 100k Ω). R2 can then be calculated Equation (3):

$$R2 = \frac{R1}{\frac{V_{OUT}}{0.6} - 1} \quad (3)$$

Figure 3 shows the feedback circuit.

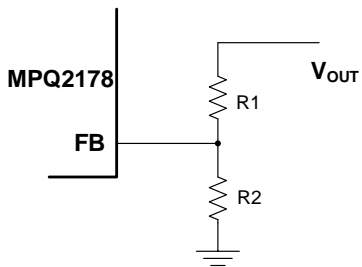

Figure 3: Feedback Network

Table 1 lists the recommended resistor values for common output voltages.

Table 1: Resistor Values for Common Output Voltages

V_{OUT} (V)	R1 (k Ω)	R2 (k Ω)
1.0	30.9 (1%)	47 (1%)
1.2	100 (1%)	100 (1%)
1.8	36 (1%)	18 (1%)
2.5	51 (1%)	16 (1%)
3.3	68 (1%)	15 (1%)

Frequency Scaling at Low Input Voltages

Under heavy-load conditions, the HS-FET voltage drops as t_{ON} increases and the duty is extended. At low input voltages and heavy-load conditions, if the minimum off time (t_{MIN_OFF}) is reached, then the frequency scales down. To keep f_{SW} constant, a higher V_{OUT} requires a higher V_{IN} under heavy loads. For a 1.8V V_{OUT} , V_{IN} should be above 2.9V to keep f_{SW} above 2MHz at a 2A load. When the frequency starts to scale down, estimate V_{IN} with Equation (4):

$$V_{IN} = \frac{V_{OUT} + R_{DS(ON)_P} \times I_{OUT}}{1 - \frac{t_{MIN_OFF}}{400 \times 10^{-9}}} \quad (4)$$

Where the maximum t_{MIN_OFF} is 125ns.⁽⁹⁾

Note:

9) Guaranteed by design and bench characterization. Not tested in production.

Selecting the Inductor

A 0.47 μ H to 1.5 μ H inductor is recommended for most applications. Select an inductor with a DC resistance below 25m Ω to optimize efficiency.

High-frequency, switch-mode power supplies with magnetic devices such as the MPQ2178 can have strong electromagnetic interference (EMI). Unshielded power inductor should be avoided, as they provide poor magnetic shielding. Shielded inductor, such as metal alloy or multi-layer chip power inductors, are recommended, as they effectively reduce EMI.

For most designs, the inductance (L_1) can be estimated with Equation (5):

$$L_1 = \frac{V_{OUT} \times (V_{IN} - V_{OUT})}{V_{IN} \times \Delta I_L \times f_{SW}} \quad (5)$$

Where ΔI_L is the inductor ripple current.

Choose an inductor ripple current that is approximately 30% of the maximum load current. The maximum inductor peak current ($I_{L(MAX)}$) can be calculated with Equation (6):

$$I_{L(MAX)} = I_{LOAD} + \frac{\Delta I_L}{2} \quad (6)$$

Selecting the Input Capacitor

The step-down converter has a discontinuous input current, and requires a capacitor to supply AC current to the converter while maintaining the DC input voltage. Use low-ESR capacitors for the best performance. Ceramic capacitors with X5R or X7R dielectrics are highly recommended because of their low ESR and small temperature coefficients. For most applications, a 10 μ F capacitor is sufficient. Higher output voltages may require a 22 μ F capacitor to increase system stability.

The input capacitor (C1) requires an adequate ripple current rating because it absorbs the input switching current.

Estimate the RMS current in the input capacitor using Equation (7):

$$I_{C1} = I_{LOAD} \times \sqrt{\frac{V_{OUT}}{V_{IN}} \times \left(1 - \frac{V_{OUT}}{V_{IN}}\right)} \quad (7)$$

The worst case occurs at $V_{IN} = 2 \times V_{OUT}$, calculated with Equation (8):

$$I_{C1} = \frac{I_{LOAD}}{2} \quad (8)$$

For simplification, choose an input capacitor with an RMS current rating greater than half of the maximum load current.

C1 can be electrolytic, tantalum, or ceramic. When using electrolytic or tantalum capacitors, add a small, high-quality, ceramic 0.1µF capacitor as close to the IC as possible. When using ceramic capacitors, ensure that they have enough capacitance to prevent excessive voltage ripple at the input. The input voltage ripple (ΔV_{IN}) caused by the capacitance can be estimated with Equation (9):

$$\Delta V_{IN} = \frac{I_{LOAD}}{f_{SW} \times C1} \times \frac{V_{OUT}}{V_{IN}} \times \left(1 - \frac{V_{OUT}}{V_{IN}}\right) \quad (9)$$

Selecting the Output Capacitor

The output capacitor (C2) stabilizes the DC output voltage. Ceramic capacitors are recommended. Low-ESR capacitors are ideal because they effectively limit the output voltage ripple. Estimate the output voltage ripple (ΔV_{OUT}) with Equation (10):

$$\Delta V_{OUT} = \frac{V_{OUT}}{f_{SW} \times L_1} \times \left(1 - \frac{V_{OUT}}{V_{IN}}\right) \times \left(R_{ESR} + \frac{1}{8 \times f_{SW} \times C2}\right) \quad (10)$$

Where L_1 is the inductance, and R_{ESR} is the equivalent series resistance (ESR) of the output capacitor.

When using ceramic capacitors, the capacitance dominates the impedance at the switching frequency and causes the majority of the output voltage ripple.

For simplification, the output voltage ripple (ΔV_{OUT}) can be estimated with Equation (11):

$$\Delta V_{OUT} = \frac{V_{OUT}}{8 \times f_{SW}^2 \times L_1 \times C2} \times \left(1 - \frac{V_{OUT}}{V_{IN}}\right) \quad (11)$$

Ceramic capacitors with X7R or X5R dielectrics are highly recommended because of their low ESR and small temperature coefficients.

For a 2A load, a 22µF capacitor with a 0805 package (or a larger capacitor) is recommended to reduce ΔV_{OUT} during steady state operation and load transient. C2 can be smaller for applications with a lower current, or if a larger ΔV_{OUT} is acceptable.

For tantalum or electrolytic capacitors, the ESR dominates the impedance at the switching frequency. For simplification, the output voltage ripple (ΔV_{OUT}) can be estimated with Equation (12):

$$\Delta V_{OUT} = \frac{V_{OUT}}{f_{SW} \times L_1} \times \left(1 - \frac{V_{OUT}}{V_{IN}}\right) \times R_{ESR} \quad (12)$$

The characteristics of the output capacitor also affect the stability of the regulation system.

Output Discharge Blocking

When the device is disabled, an internal resistive discharge path from the OUT pin to GND is enabled to discharge the output capacitor (C2). The discharge path can be blocked by adding an external capacitor between V_{OUT} and the OUT pin (see Figure 4).

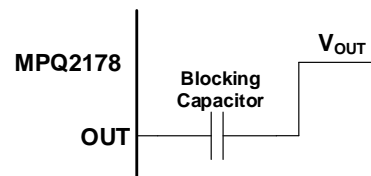

Figure 4: Circuit with V_{OUT} Discharge Blocking Capacitor

In order to avoid influencing the loop and load transient, the blocking capacitor should be at least 10nF. Larger-value blocking capacitors have no impact on loop performance, but are not necessary and have greater costs. A capacitor between 10nF and 100nF is recommended.

PCB Layout Guidelines

Efficient PCB layout is critical for proper function. Poor layout design can result in poor line or load regulation and stability issues. For the best results, refer to Figure 5 and follow the guidelines below:

1. Place the high-current paths (GND, V_{IN} , and SW) as close as possible to the device with short, direct, and wide traces.
2. Place the input capacitor (C1) as close as possible to the V_{IN} and GND pins.
3. Place the output capacitor GND needs to close the chip's GND pins.
4. For the adjustable output version, place the external feedback resistors next to the FB pin.
5. Keep the switching node (SW) short and away from the feedback network.
6. Keep the V_{OUT} sense line as short as possible and place it as far from the power inductor as possible. It must not surround the inductor or be close to SW.

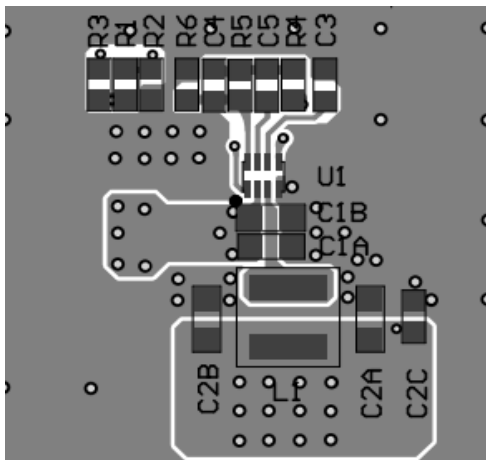

Top Layer

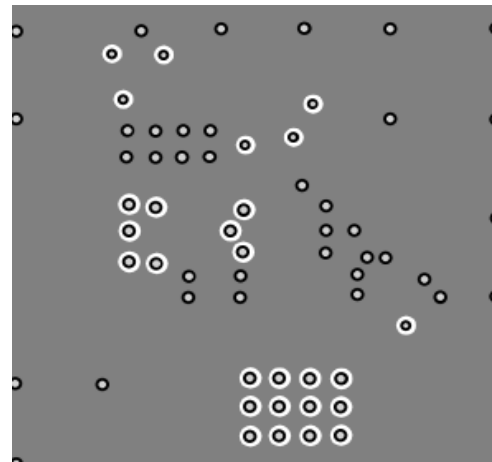

Mid-Layer 1

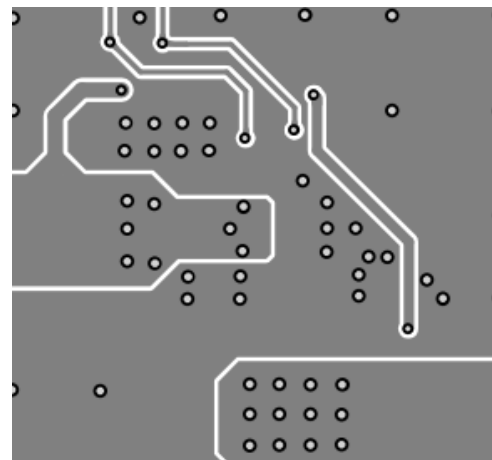

Mid-Layer 2

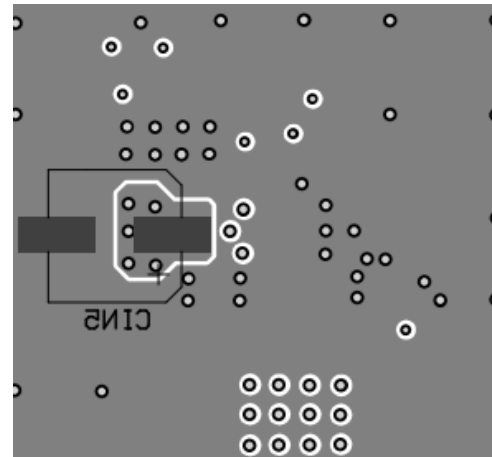

Bottom Layer

Figure 5: Recommended PCB Layout

TYPICAL APPLICATION CIRCUITS

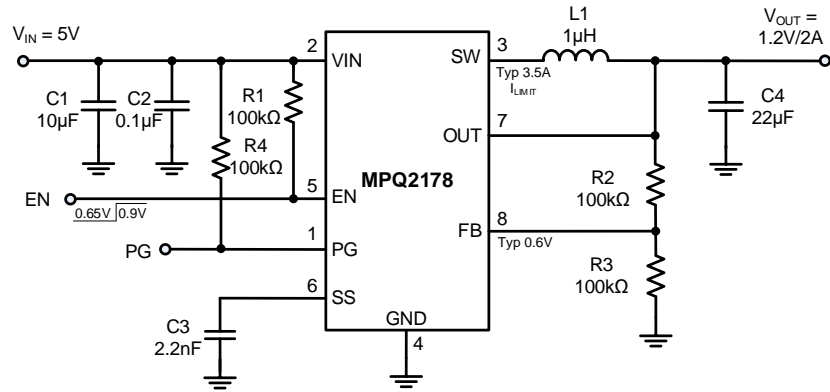

Figure 6: 1.2V Output Application Circuit for Adjustable Output Version

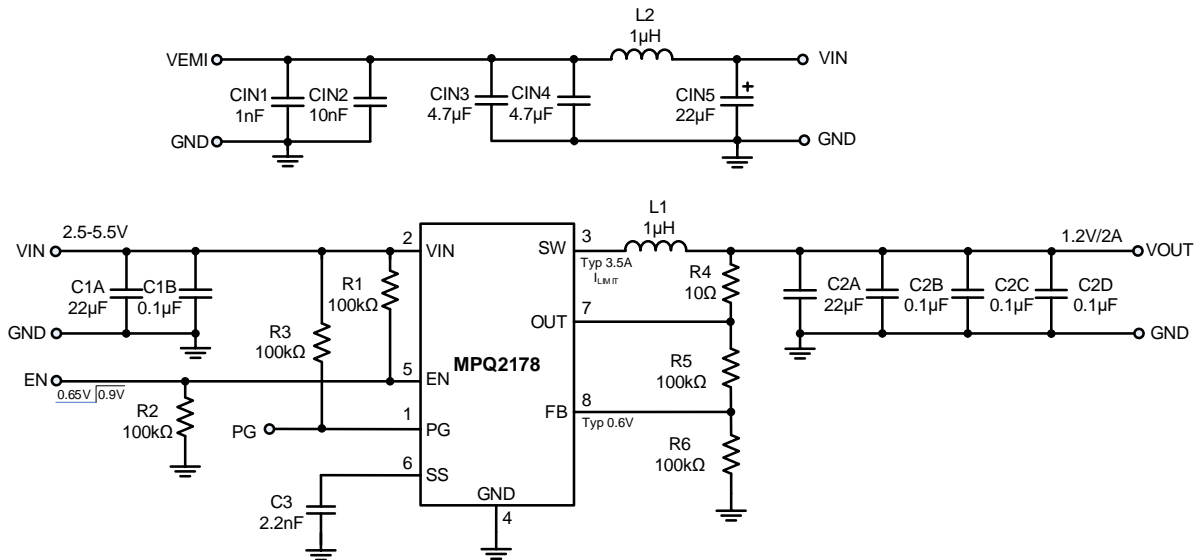

Figure 7: 1.2V Output Application Circuit for Adjustable Output Version with EMI Filter

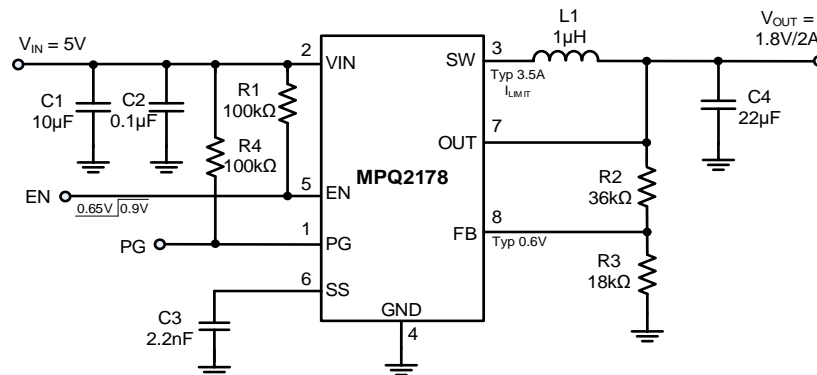
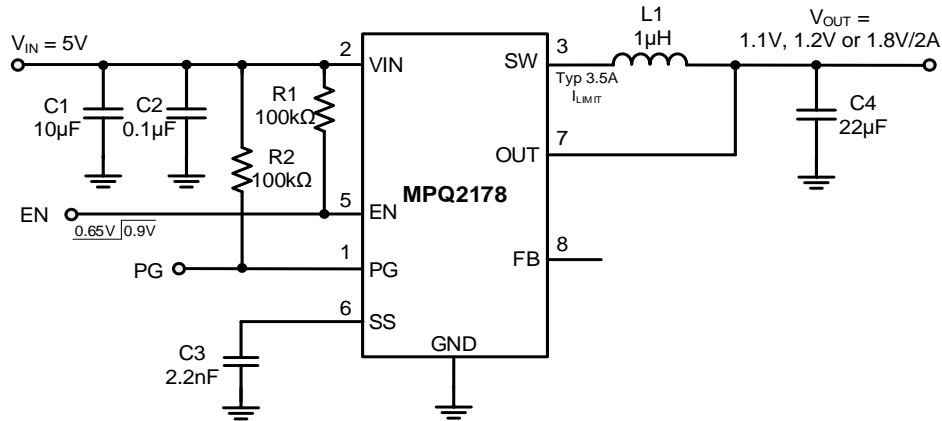
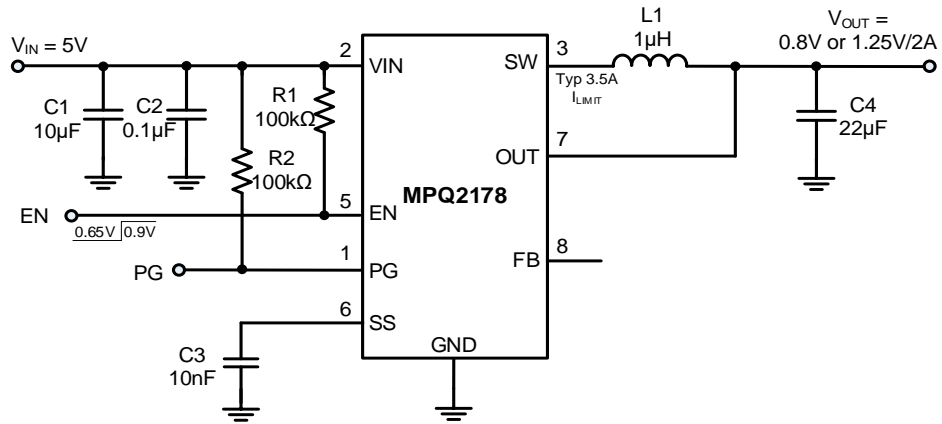
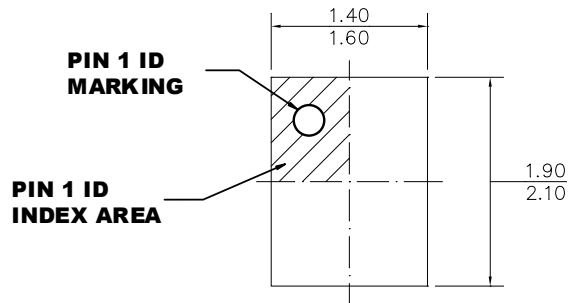

Figure 8: 1.8V Output Application Circuit for Adjustable Output Version

TYPICAL APPLICATION CIRCUITS (continued)

Figure 9: Typical Application Circuit for 1.1V, 1.2V, and 1.8V Fixed Output Versions

Figure 10: Typical Application Circuit for 0.8V and 1.25V Fixed Output Versions

PACKAGE INFORMATION

QFN-8 (1.5mmx2mm) Wettable Flank

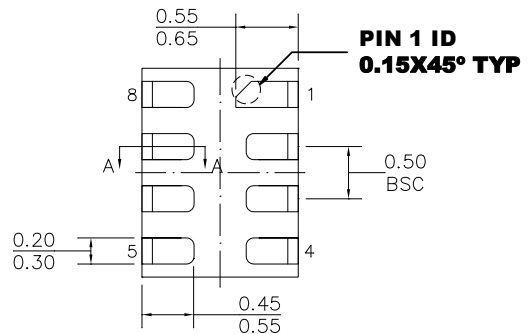

TOP VIEW



BOTTOM VIEW

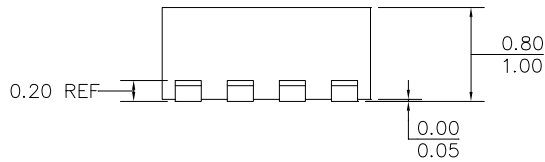

SIDE VIEW

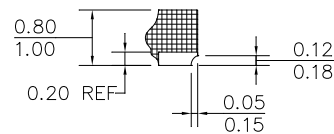

SECTION A-A

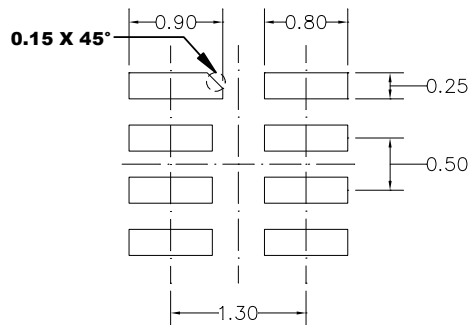

RECOMMENDED LAND PATTERN

NOTE:

- 1) THE LEAD SIDE IS WETTABLE.
- 2) ALL DIMENSIONS ARE IN MILLIMETERS.
- 3) LEAD COPLANARITY SHALL BE 0.08 MILLIMETERS MAX.
- 4) JEDEC REFERENCE IS MO-220.
- 5) DRAWING IS NOT TO SCALE.

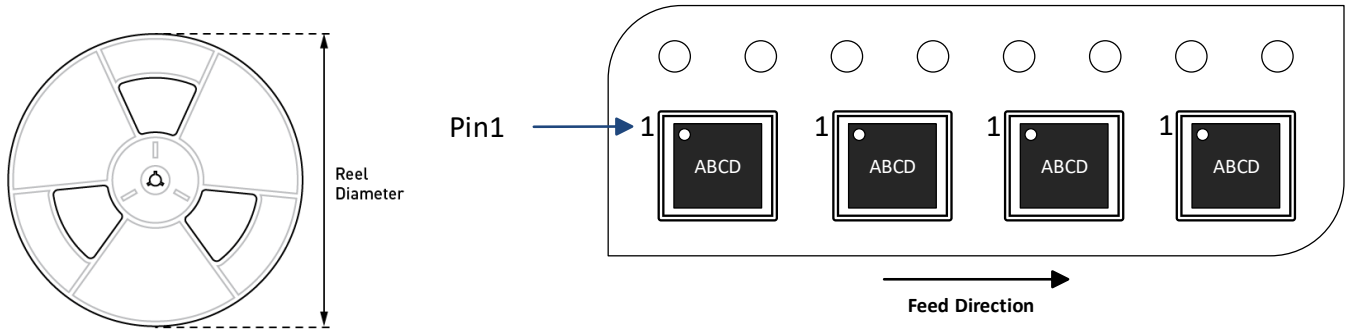
CARRIER INFORMATION

Part Number	Package Description	Quantity /Reel	Quantity /Tube	Quantity /Tray	Reel Diameter	Carrier Tape Width	Carrier Tape Pitch
MPQ2178GQHE-Z	QFN-8 (1.5mmx2mm)	5000	N/A	N/A	13in	8mm	4mm
MPQ2178GQHE-AEC1-Z							
MPQ2178GQHE-8-AEC1-Z							
MPQ2178GQHE-11-AEC1-Z							
MPQ2178GQHE-12-AEC1-Z							
MPQ2178GQHE-125-AEC1-Z							
MPQ2178GQHE-18-AEC1-Z							

REVISION HISTORY

Revision #	Revision Date	Description	Pages Updated
1.0	4/29/2021	Initial Release	-
1.1	5/4/2023	Added the fixed output options in the Features section; added note 1; updated formatting; added the MPSafe logo; updated the header to 6V	1
		Updated formatting	2
		Updated the input voltage to 6V in the header	2-27
		Added the Output Voltage column in the Ordering Information section; added note 2; added the MPQ2178-8, MPQ2178-11 and MPQ2178-125 SKUs to the Ordering Information section; added the "Wettable flank" note	3
		Added the MPQ2178-8, MPQ2178-11 and MPQ2178-125 top marking information in the Top Marking section	4
		Added the SW voltage range in the Absolute Maximum Ratings section; updated the supply voltage to 6V; corrected the evaluation board part number to EVQ2178-QH-00A; corrected Note 6 with the EVQ2178-QH-00A	5
		Updated the input voltage to 6V maximum; updated the feedback current, output regulation voltage (fixed output version), and soft-start current sections with the parameters for the MPQ2178-8, MPQ2178-11, and MPQ2178-125	6
		Added curves for the MPQ2178-8 and MPQ2178-125	10
		Added EMI test results	13
		Updated Figure 2 with new product information	18
		Updated the supply voltage in the Operation section to 6V	19
		Updated Figure 5 with new PCB layout	23
		Added Figure 7	24
		Added Figure 9 and Figure 10	25
Added the MPQ2178-8, MPQ2178-11 and MPQ2178-125 SKUs in the Carrier Information section	27		

NOTICE: The information in this document is subject to change without notice. Please contact MPS for current specifications. Users should warrant and guarantee that third party Intellectual Property rights are not infringed upon when integrating MPS products into any application. MPS will not assume any legal responsibility for any said applications.