

E43319

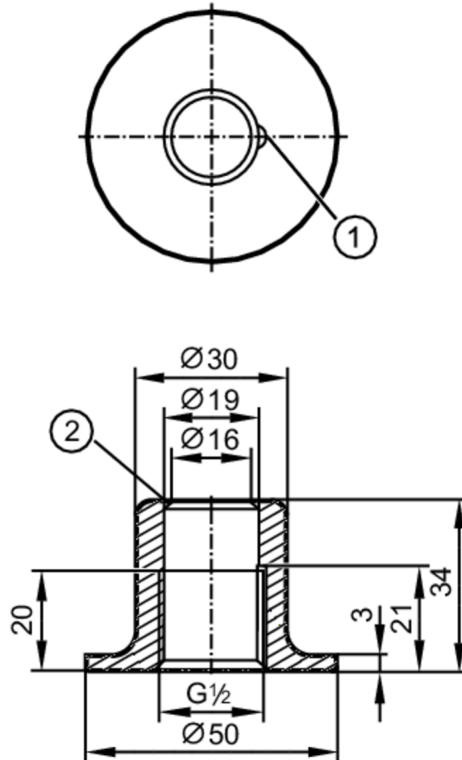

Welding adapter for process sensors

ADAPT G1/2 WELDING POT



- 1 Leakage port
- 2 sealing edge



EC 1935/2004 EHEDG Certified FCM FDA

Application	
Design	long design for deeper installation
Pressure rating [bar]	50
Note on pressure rating	for the connection sensor - adapter
Mechanical data	
Weight [g]	200
Materials	stainless steel (1.4435 / 316L)
Sensor connection	G 1/2
Process connection	welding adapter D50
Surface characteristics Ra/Rz of the wetted parts	0.4 / 4
Accessories	
Accessories (supplied)	O-rings:, FKM
Remarks	
Pack quantity	1 pcs.