

2

1

### Top View of Assembly

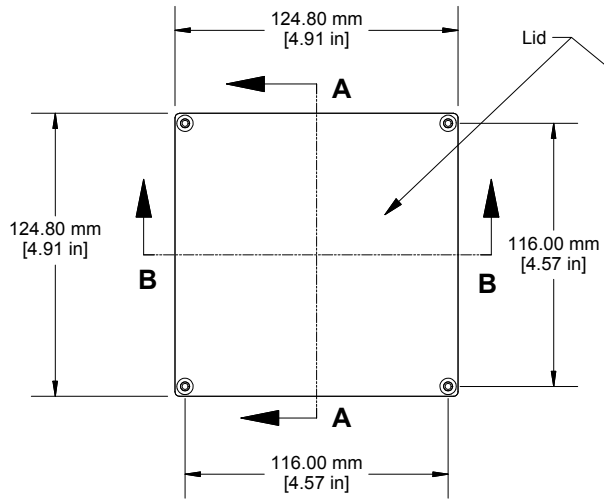

### SECTION A-A End View of Assembly

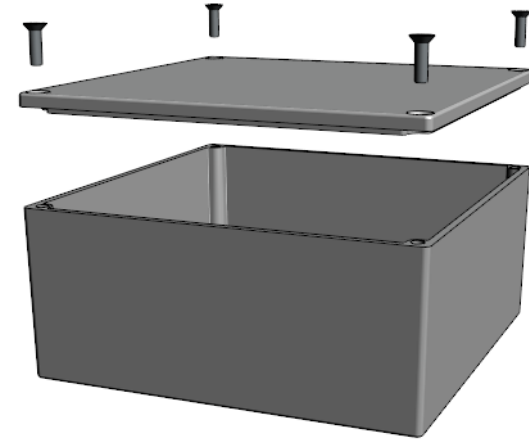
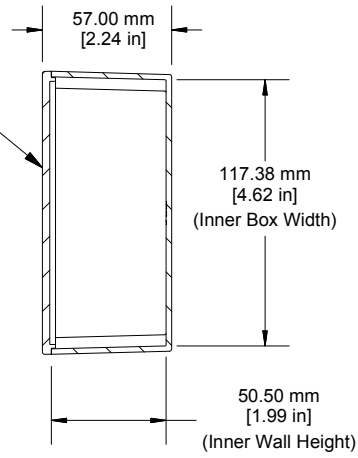

### SECTION B-B Side View of Assembly

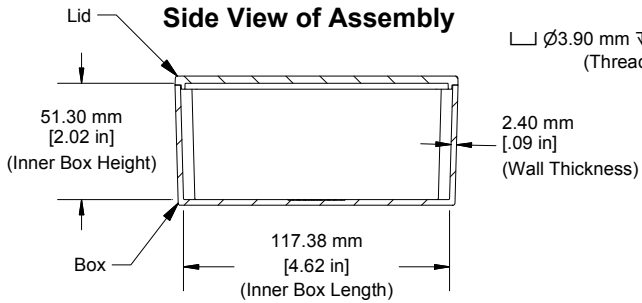

### Top View Looking Inside Box

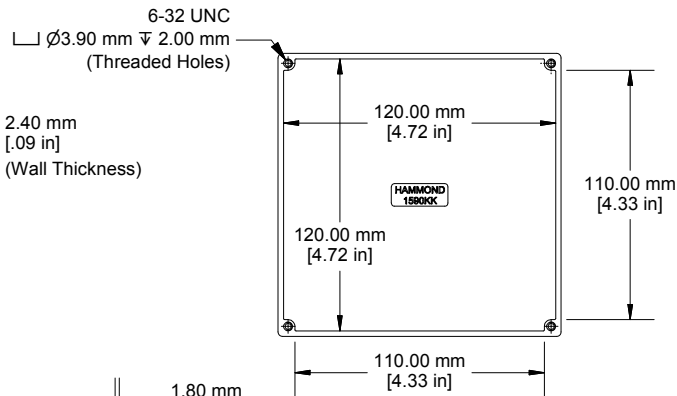

### Lid

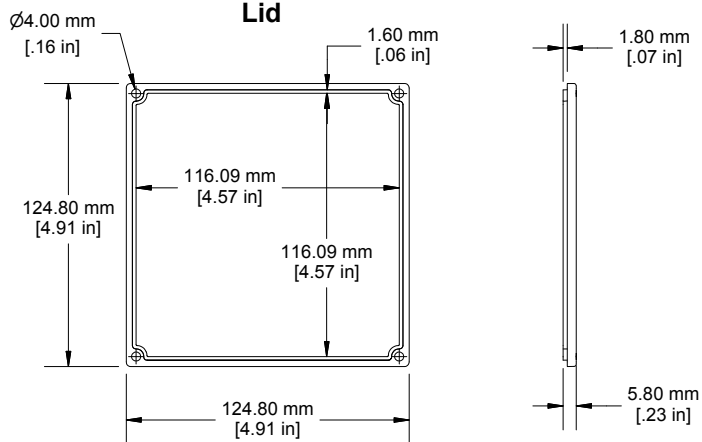

Enclosures can be Factory Modified ( Milling, Drilling, Printing etc.)  
Contact Factory [mjm@hammondmfg.com](mailto:mjm@hammondmfg.com) for quotes  
Solid models of this enclosure available in STEP or IGES.

#### NOTE

Purchased assembly includes box, lid and 4 cover screws.  
Box and lid are made from Diecast Aluminum Alloy.  
Silicone Gasket supplied with liquid resistant enclosure.

#### PART NUMBERS

1590KK Enclosure	
Natural Finish Enclosure	1590KK
Black Textured Enclosure	1590KKBK
1590KK Liquid Resistant Enclosure (Silicone Gasket)	
Natural Finish Enclosure	1590WKK
Black Textured Enclosure	1590WKKBK

#### ACCESSORIES

Recommended Torque: 75 ozf.in / 55 cN.m

#### Liquid Resistant Cover Screws

Stainless Steel Cover Screws (Pkg 100) [6-32 x 1/2" With O-Ring]	1590WMS100
Black Stainless Steel Cover Screws (Pkg 100) [6-32 x 1/2" With O-Ring]	1590WMS100BK
Standard Cover Screws	
Plated Cover Screws (Pkg 100) [6-32 x 1/2"]	1590MS100
Black Cover Screws (Pkg 100) [6-32 x 1/2"]	1590MS100BK



Dimensions:  
mm  
[inches]

2

1