

# DI5024

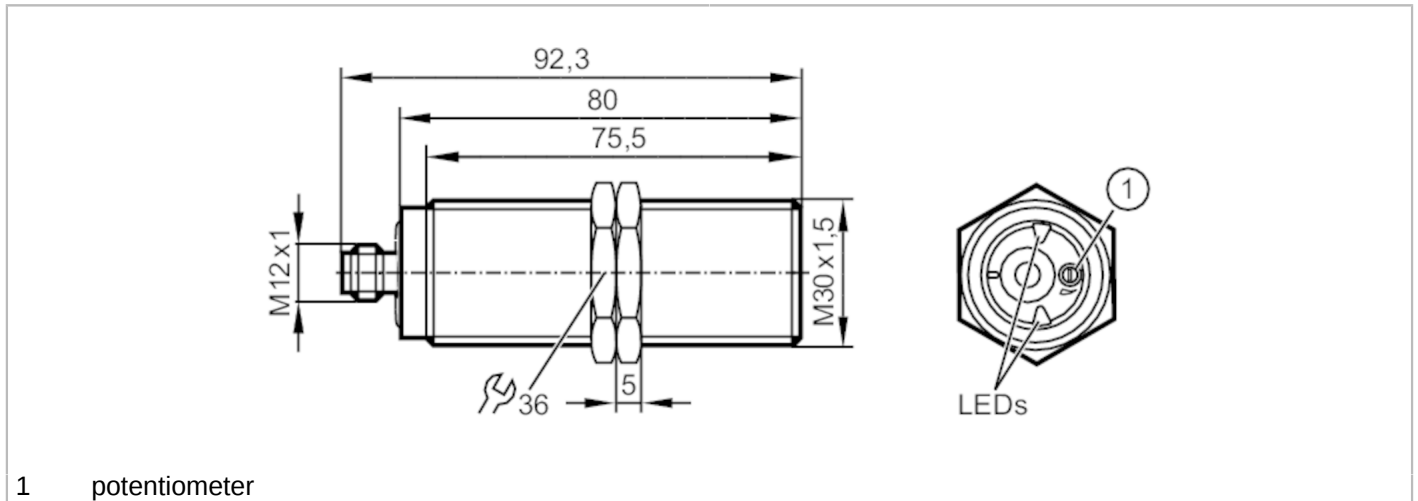

## Compact evaluation unit for speed monitoring

DIA3010-WRKG/IO/US



1 potentiometer



Product characteristics	
Electrical design	PNP/NPN
Output function	normally open / normally closed; (parameterisable)
Sensing range [mm]	10
Communication interface	IO-Link
Housing	threaded type
Dimensions [mm]	M30 x 1.5 / L = 92.3
Application	
Application	simple evaluation of rotating and linear movement with regard to underspeed; blocking
Electrical data	
Nominal voltage DC [V]	10...36
Current consumption [mA]	< 22
Protection class	III
Reverse polarity protection	yes
Outputs	
Electrical design	PNP/NPN
Output function	normally open / normally closed; (parameterisable)
Max. voltage drop switching output DC [V]	2.5
Permanent current rating of switching output DC [mA]	250
Short-time current rating of switching output [mA]	250
Short-circuit proof	yes
Overload protection	yes
Detection zone	
Sensing range [mm]	10
Sensing range adjustable	no
Operating distance [mm]	0...8.1

# DI5024



## Compact evaluation unit for speed monitoring

DIA3010-WRKG/IO/US

Measuring/setting range		
Setting range	[Imp/min]	5...3600
Accuracy / deviations		
Correction factor		steel: 1 / stainless steel: 0.7 / brass: 0.5 / aluminium: 0.4 / copper: 0.3
Hysteresis	[% of Sr]	10
Response times		
Start-up delay	[s]	0...30; (In steps of: 100 ms; Default: 15 s)
Max. damping frequency	[Imp/min]	18000
Software / programming		
Adjustment of the switch point		Multiturn potentiometer or IO-Link
Interfaces		
Communication interface		IO-Link
Operating conditions		
Ambient temperature	[°C]	-25...80
Storage temperature	[°C]	-25...80
Protection		IP 65; IP 67
Tests / approvals		
EMC		EN 60947-5-2
Shock resistance		DIN EN 60947-5-2
Vibration resistance		DIN EN 60947-5-2
MTTF	[years]	3262
Mechanical data		
Weight	[g]	250
Housing		threaded type
Mounting		flush mountable
Dimensions	[mm]	M30 x 1.5 / L = 92.3
Thread designation		M30 x 1.5
Materials		brass special coating; PA; stainless steel; TPE-U
Tightening torque	[Nm]	50
Displays / operating elements		
Display	switching status	1 x LED, green
Accessories		
Accessories (supplied)		lock nuts: 2
Electrical connection		
Connector: 1 x M12		
		

# DI5024



## Compact evaluation unit for speed monitoring

DIA3010-WRKG/IO/US

### Connection

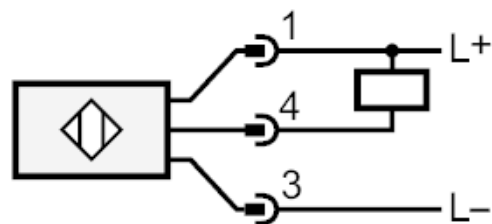
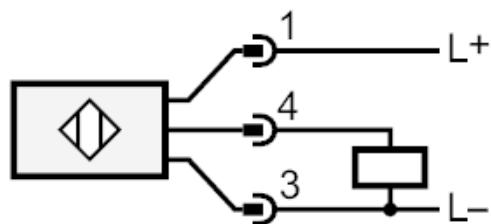

4: OUT / IO-Link