



Model Number

BB10-P-F1/25/33/35/103/115-7m

Thru-beam sensor
with fixed cable

Features

- Single-beam miniature photoelectric sensor, ideal for installing in frames or contours
- Integrated circuit
- Plug-in style housing for 13 mm hole
- Narrow opening angle, suitable for mounting in pairs
- Various frequencies for avoiding mutual interference (cross-talk immunity)
- Light on version

Product information

There is no simpler way of installing a sensor: drill the hole, clip in the sensor and you're done. What's more, the BB10 plug-in sensors for doors and turnstiles offer top performance at an extremely attractive price. The switching mechanism is integrated in the compact, self-contained and temperature-stable housing, making the BB10 suitable even for extremely cold regions with temperatures as low as -40°C.

Release date: 2014-10-30 07:55 Date of issue: 2014-10-30 809331_eng.xml

Dimensions

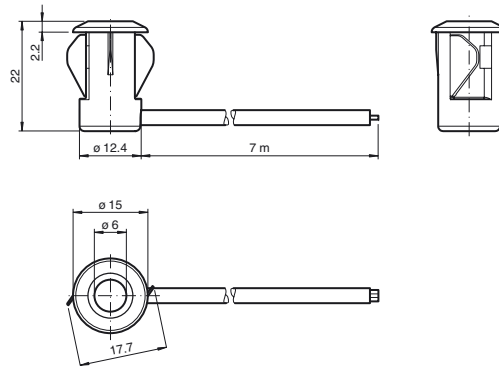

Electrical connection

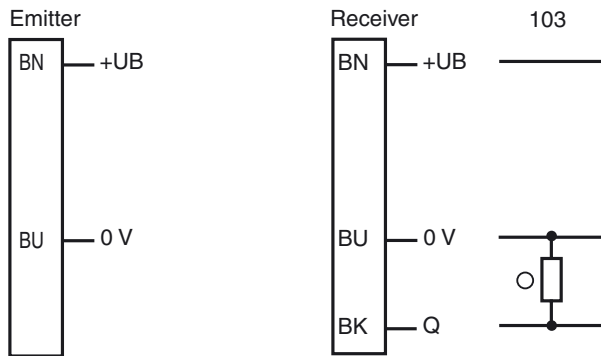

○ = Light on
● = Dark on

Indicators/operating means

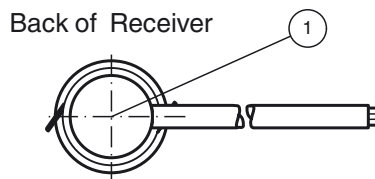

1	Signal display	red
---	----------------	-----

Technical data**System components**

Emitter	BB10-T-F1/33/35/115-7m
Receiver	BB10-R-F1/25/33/35/103/115-7m

General specifications

Effective detection range	0 ... 3 m
Threshold detection range	4 m
Light source	IREL
Light type	modulated infrared light , 880 nm
Diameter of the light spot	approx. 250 mm at a distance of 1 m
Angle of divergence	Emitter: +/- 3 ° Receiver: +/- 10 °
Optical face	frontal
Ambient light limit	halogen light 100000 Lux ; according to EN 60947-5-2:2007

Functional safety related parameters

MTTF _d	795 a
Mission Time (T _M)	20 a
Diagnostic Coverage (DC)	0 %

Indicators/operating means

Function indicator	LED red: lights up when receiving the light beam ; flashes when falling short of the stability control; OFF when light beam is interrupted
--------------------	--

Electrical specifications

Operating voltage	U _B	10 ... 30 V DC
No-load supply current	I ₀	Emitter: ≤ 20 mA Receiver: ≤ 10 mA

Output

Switching type	light on	
Signal output	1 PNP output, short-circuit protected, reverse polarity protected, open collector	
Switching voltage	max. 30 V DC	
Switching current	max. 100 mA	
Voltage drop	U _d	≤ 1.5 V DC
Switching frequency	f	100 Hz
Response time		5 ms

Ambient conditions

Ambient temperature	-40 ... 60 °C (-40 ... 140 °F) , fixed -20 ... 60 °C (-4 ... 140 °F) , movable
Storage temperature	-40 ... 70 °C (-40 ... 158 °F)
Relative humidity	90 % , noncondensing

Mechanical specifications

Degree of protection	IP67
Connection	7 m fixed cable Receiver: grey ; Emitter: black
Material	
Housing	PC , black
Optical face	Plastic pane
Mass	approx. 100 g per device

Compliance with standards and directives

Directive conformity	
EMC Directive 2004/108/EC	EN 60947-5-2:2007
Standard conformity	
Product standard	EN 60947-5-2:2007 IEC 60947-5-2:2007

Approvals and certificates

CCC approval	CCC approval / marking not required for products rated ≤36 V
UN/ECE Regulation No. 10 (E1)	Type-approval number: 036938

Typical applications

- Monitoring function for turnstiles
- Activation function for restarting escalators
- Monitoring of industrial gates
- Person detection for automatic doors and gates

Detection area

Curves/Diagrams

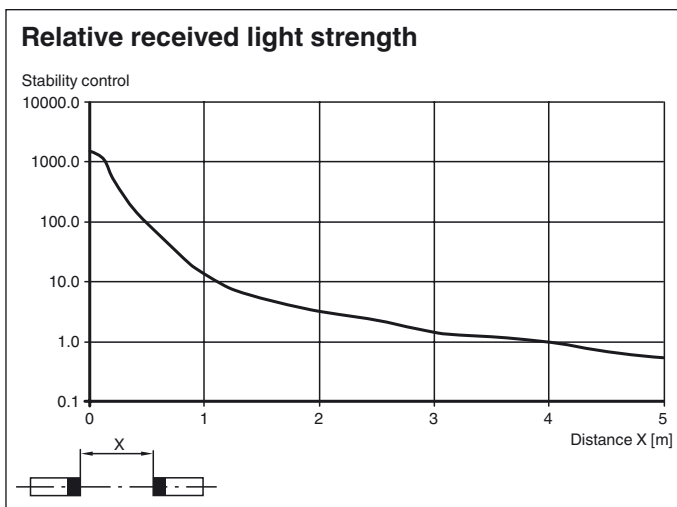
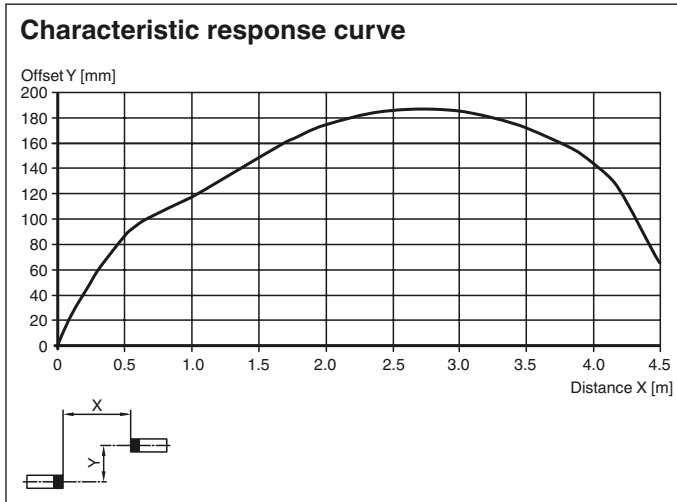

Operating principle

The thru-beam sensor requires two devices for operation; a light source and a light receiver. The light source and receiver must be optically aligned with one another in a single line. The infrared light emitted from the source is recorded by the receiver and evaluated. The sensor detects both people and objects for as long as an object interrupts the detection beam, regardless of movement and surface structure.

Function

Static detection:

The sensor detects both people and objects for as long as an object interrupts the detection beam, regardless of movement and surface structure.

		Electronic output
Light ON /25	Person located within beam	Inactive
	No people located within beam	Active
Dark ON /59	Person located within beam	Active
	No people located within beam	Inactive

Optics:

The relatively wide opening angles allow the sensors to be mounted quickly without any alignment issues. Function is maintained even if mounting profiles are slightly distorted.

Mounting:

Thanks to its compact dimensions, the sensor fits in U profiles or behind any covers.

Release date: 2014-10-30 07:55 Date of issue: 2014-10-30 809331_eng.xml

Sheet thickness [mm]	Hole diameter [mm]	
		13
1	OK	X
2	OK	OK
3	OK	OK

X = mounting not possible

OK = mounting possible

Mounting for dual-beam protection:

For dual-beam versions, two light sources and receivers are required.

When using thru-beam sensors with two different transmission frequencies (F1 and F2), it is not necessary to observe a minimum beam distance between the thru-beam sensors.

When using thru-beam sensors with the same transmission frequency:

Ensure that the minimum beam distance is 20 cm and that the transmitter and receiver are arranged in a cross formation.

