

- E cores are supplied as single units

Magnetic characteristics (per set)

$$\Sigma l/A = 1,12 \text{ mm}^{-1}$$

$$l_e = 67 \text{ mm}$$

$$A_e = 60 \text{ mm}^2$$

$$A_{\min} = 49 \text{ mm}^2$$

$$V_e = 4\,000 \text{ mm}^3$$

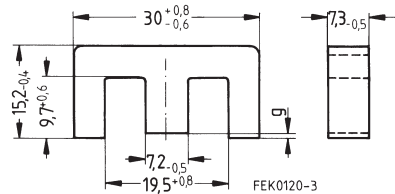
Approx. weight 22 g/set

Ungapped

Material	A_L value nH	μ_e	$A_{L1\min}$ nH	P_V W/set	Ordering code
N30	3100 + 30/- 20 %	2760			B66319-G-X130
N27	1700 + 30/- 20 %	1510	1410	< 0,81 (200 mT, 25 kHz, 100°C)	B66319-G-X127
N87	1900 + 30/- 20 %	1690	1410	< 2,20 (200 mT, 100 kHz, 100°C)	B66319-G-X187

Gapped

Material	g mm	A_L value approx. nH	μ_e	Ordering code ** = 27 (N27) = 87 (N87)
N27,	0,10 ± 0,02	460	410	B66319-G100-X1**
N87	0,18 ± 0,02	300	265	B66319-G180-X1**
	0,34 ± 0,02	195	175	B66319-G340-X1**

The A_L value in the table applies to a core set comprising one ungapped core (dimension $g = 0$) and one gapped core (dimension $g > 0$).

Calculation factors (for formulas, see “E cores: general information”, page 382)

Material	Relationship between air gap – A_L value		Calculation of saturation current			
	$K1$ (25 °C)	$K2$ (25 °C)	$K3$ (25 °C)	$K4$ (25 °C)	$K3$ (100 °C)	$K4$ (100 °C)
N27	90	- 0,708	156	- 0,847	144	- 0,865
N87	90	- 0,708	154	- 0,796	140	- 0,873

Validity range: $K1, K2: 0,10 \text{ mm} < s < 2,00 \text{ mm}$
 $K3, K4: 560 \text{ nH} < A_L < 60 \text{ nH}$

Coil former (magnetic axis horizontal or vertical)

Material: GFR polyterephthalate (UL 94 V-0, insulation class to IEC 60085: F \triangleq max. operating temperature 155 °C), color code black

Solderability: to IEC 60068-2-20, test Ta, method 1 (aging 3): 235 °C, 2 s

Resistance to soldering heat: to IEC 60068-2-20, test Tb, method 1B: 350 °C, 3,5s

Winding: see "Processing Notes", page 159

Squared pins

Yoke

Material: Stainless spring steel (0,4 mm)

Coil former						Ordering code
Figure	Sections	A_N mm ²	l_N mm	A_R value $\mu\Omega$	Pins	
1	1	90	56	21	14	B66232-A1114-T1
2	1	90	56	21	12	B66232-J1112-T1
Yoke (ordering code per piece, 2 are required)						B66232-A2010

Figure 1, horizontal version

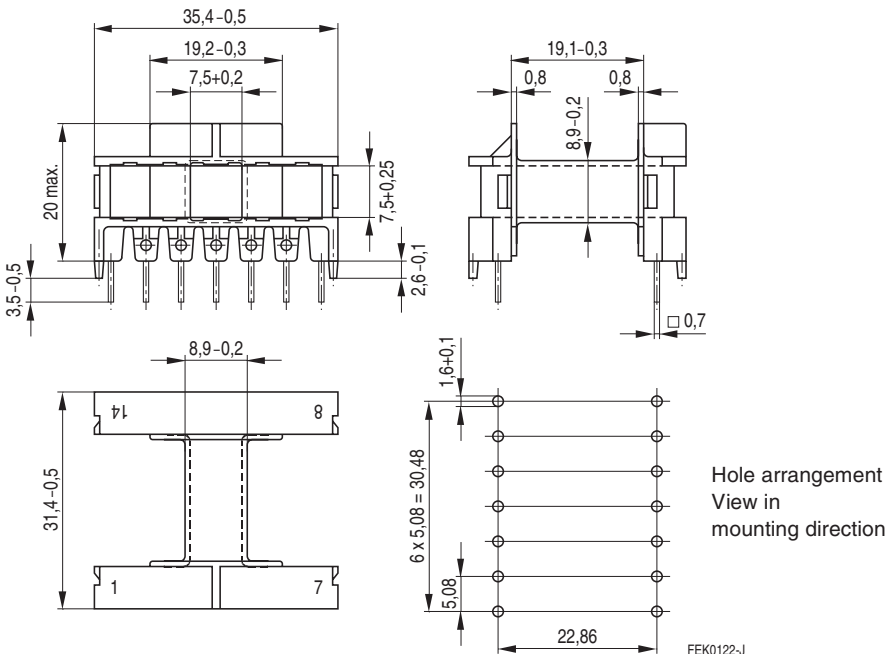

Herausgegeben von EPCOS AG

Marketing Kommunikation, Postfach 80 17 09, 81617 München, DEUTSCHLAND

© EPCOS AG 2000. Alle Rechte vorbehalten. Vervielfältigung, Veröffentlichung, Verbreitung und Verwertung dieser Broschüre und ihres Inhalts ohne ausdrückliche Genehmigung der EPCOS AG nicht gestattet.

Mit den Angaben in dieser Broschüre werden die Bauelemente spezifiziert, keine Eigenschaften zugesichert. Bestellungen unterliegen den vom ZVEI empfohlenen Allgemeinen Lieferbedingungen für Erzeugnisse und Leistungen der Elektroindustrie, soweit nichts anderes vereinbart wird.

Diese Broschüre ersetzt die vorige Ausgabe.

Fragen über Technik, Preise und Liefermöglichkeiten richten Sie bitte an den Ihnen nächstgelegenen Vertrieb der EPCOS AG oder an unsere Vertriebsgesellschaften im Ausland.

Bauelemente können aufgrund technischer Erfordernisse Gefahrstoffe enthalten. Auskünfte darüber bitten wir unter Angabe des betreffenden Typs ebenfalls über die zuständige Vertriebsgesellschaft einzuholen.

Published by EPCOS AG

Marketing Communications, P.O. Box 80 17 09, 81617 Munich, GERMANY

© EPCOS AG 2000. All Rights Reserved. Reproduction, publication and dissemination of this brochure and the information contained therein without EPCOS' prior express consent is prohibited.

The information contained in this brochure describes the type of component and shall not be considered as guaranteed characteristics. Purchase orders are subject to the General Conditions for the Supply of Products and Services of the Electrical and Electronics Industry recommended by the ZVEI (German Electrical and Electronic Manufacturers' Association), unless otherwise agreed.

This brochure replaces the previous edition.

For questions on technology, prices and delivery please contact the Sales Offices of EPCOS AG or the international Representatives.

Due to technical requirements components may contain dangerous substances. For information on the type in question please also contact one of our Sales Offices.