

NOTES

- MATERIAL** (ABS) FLAME RETARDANT UL94 V0 MATERIAL WITH BRASS INSERTS IN CORNER POSTS.
(STYRENE) IS NON-FLAME RETARDANT WITHOUT BRASS INSERTS.
- PARTS** (ABS) VERSION MACHINE SCREWS M3-0.5 x 18mm. REPLACEMENT PN 1594MS100 (100 / BAG). ABS VERSION MACHINE SCREWS FOR THE WATER RESISTANT BOX REPLACEMENT PN 1594WMS100 (STYRENE) VERSION SELF TAPPING #4 x 1.0". REPLACEMENT PN 1594TS100 (100 / BAG).
- COLORS** (ABS) BLACK, GRAY (STYRENE) GRAY ONLY.

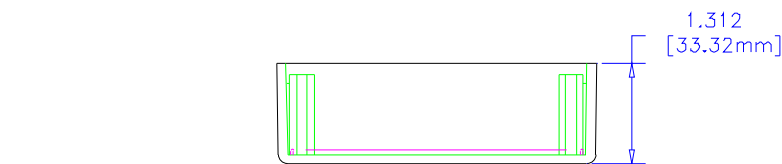
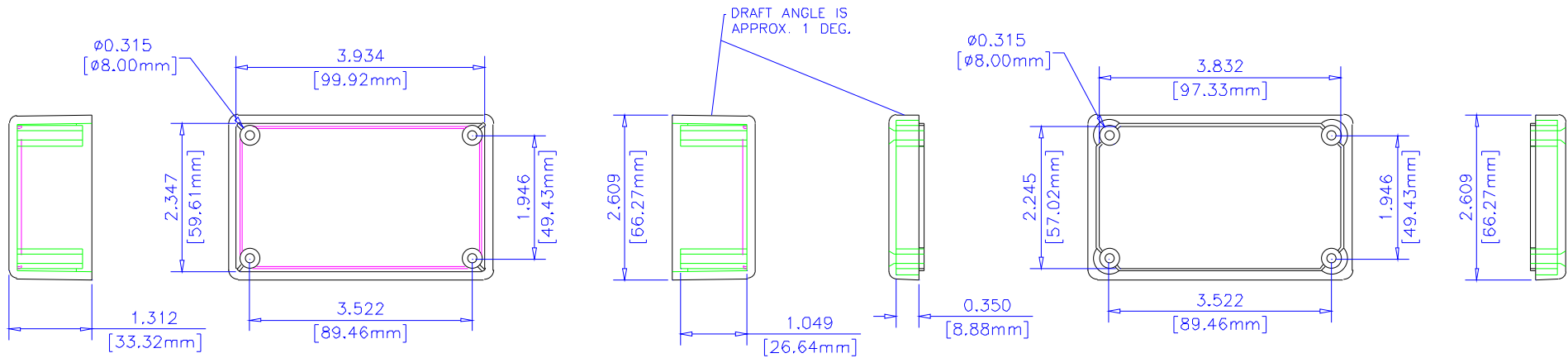
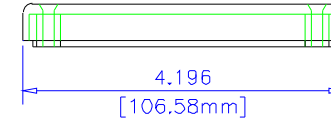
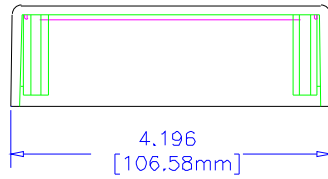

BOTTOM

TOP

UNLESS OTHERWISE SPECIFIED	
DIMENSIONS ARE IN INCHES	
XX	+/- .1
XX	+/- .06
XXX	+/- .015
XXXX	+/- .009
ANGLES	+/- .5 DEG.



**HAMMOND
MANUFACTURING**

WEB: WWW.HAMMONDMFG.COM

TITLE HAMMOND 1594 SERIES
PLASTIC ENCLOSURE

DRAWN BY MJM DATE 01/06/01

SCALE PAGE 1 OF 1

PART NUMBER
1594C

NOTICE:
HAMMOND GRANTS PERMISSION TO THE MATERIAL OR THE DRAWING TO BE USED AS A REFERENCE FOR ENGINEERING INFORMATION ONLY. THIS INFORMATION MAY NOT BE USED TO MANUFACTURE PRODUCTS WITHOUT WRITTEN PERMISSION FROM HAMMOND MANUFACTURING.