

# VEROWIRE and Prototyping Board Accessories

## Verowire

The Verowire wiring system is ideal for prototypes, breadboards and limited production runs. Finished results are of a high standard with a neat orderly appearance achieved in significantly less time than more conventional methods.

### Features

- Low profile
- High speed applications
- Suitable for high-density wiring
- No headers required
- Low cost

### Wire specification

Diameter of wire:	0,20 mm (34 AWG)
Insulation:	Self-fluxing polyurethane*
Insulation Thickness:	0,005 mm
Proof Voltage:	600V d.c.
Current Rating:	0,100 A
Resistance @ 20°C:	0,857Ω/m
Length of wire/spool:	40 m
Colours:	Pink or Gold

Verowire		Ordering information
Description	Unit of Sale	Order code
Wiring pen	1	<b>79-1732</b>
Spools wire; 2 gold, 2 pink	4	<b>79-19038</b>
Spool wire, Pink	4	<b>79-1737</b>
Spool wire, Gold	4	<b>79-1739</b>
Wiring combs	100	<b>79-1735</b>
Half pin	1000	<b>18-0223</b>

## Card support – ejector mechanism

Supplied as an accessory for any extender board, this device attaches to the end and guides/supports the circuit board under test. Supplied as a kit comprising 2 support – ejector assemblies, 4 M3 x 8 long screws and 4 M3 nuts.

Card support – Ejector mechanism		Ordering information
Description		Order code
Card support – ejector		<b>22-2427</b>

## Spot face cutter

Used to break copper tracks on a PCB.

Can be used by hand or, with the handle removed, fitted into a bench drill

Spot Face Cutter		Ordering information
Description		Order code
Spot Face Cutter		<b>22-0239</b>

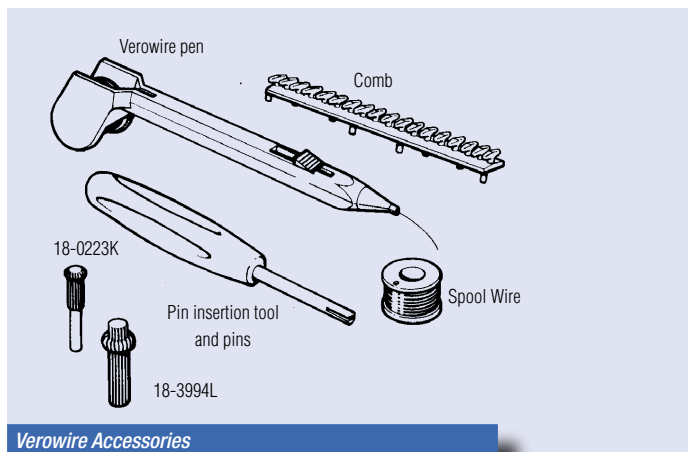

Verowire Accessories

**WARNING!**  
When soldering through polyurethane enamelled wire a small quantity of TDI gas is produced. Use in a well ventilated room.

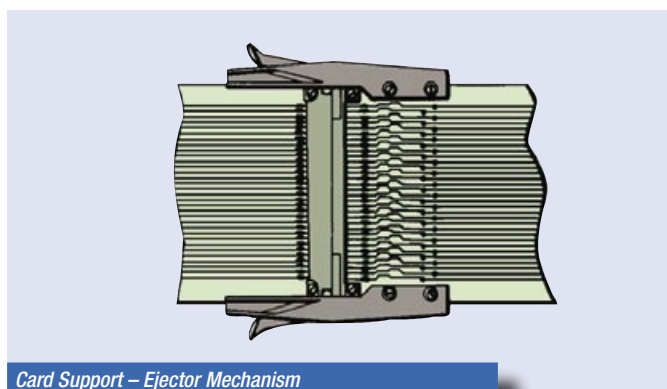

Card Support – Ejector Mechanism

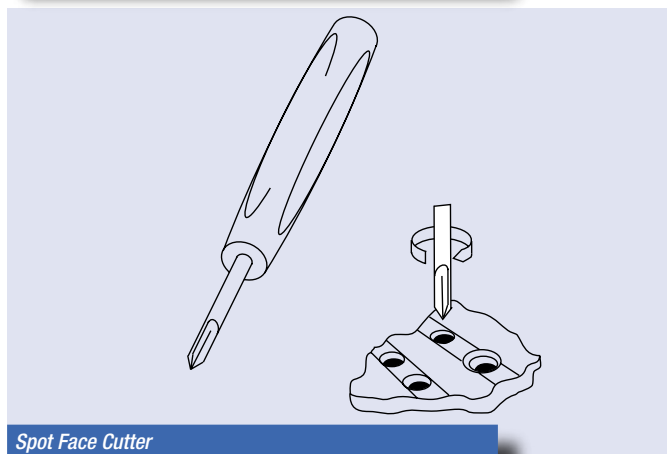

Spot Face Cutter