

# Amphenol PCD

<b>Engineering Change Request</b>		ECR Number	R4110W
Initiator:	Celine.xie	Date:	2020.2.21
Review by supervisor:	<i>Seibao</i>	Date:	2020.2.21
Part number description			
K3 Code <b>(Pls list all part numbers)</b>	Drawing Number	Old revision	New revision
HVSL800082XXXX	C-HVSL800082XXXX	C	D
TAM02SA351	C-HVSL800082XXXX	C	D
TAM02SA501	C-HVSL800082XXXX	C	D
TAM02SB351	C-HVSL800082XXXX	C	D
TAM02SB501	C-HVSL800082XXXX	C	D
TAM02SC351	C-HVSL800082XXXX	C	D
TAM02SC501	C-HVSL800082XXXX	C	D
HVSLP800082A101	C-HVSLP800082XXXX	1	2
HVSLP800082A104	C-HVSLP800082XXXX	1	2
HVSLP800082B101	C-HVSLP800082XXXX	1	2
HVSLP800082B102	C-HVSLP800082XXXX	1	2
HVSLP800082B104	C-HVSLP800082XXXX	1	2
Reason of change:			
<input type="checkbox"/> Customer requirement <input type="checkbox"/> Supplier request <input type="checkbox"/> internal improvement <input type="checkbox"/> corrective <input checked="" type="checkbox"/> other			
<u>Pls describe here in detail:</u>			
HVSL800082, HVSLP800082 RA plug serial : Cancel parts slug hole of the body to improve the polarization feature effectiveness. ,this change does not affect the insertion mating on both new and old version, and the insertion force is promoted from 150N to 300N.			

# Amphenol PCD

Before change

HVSL800082AXXX

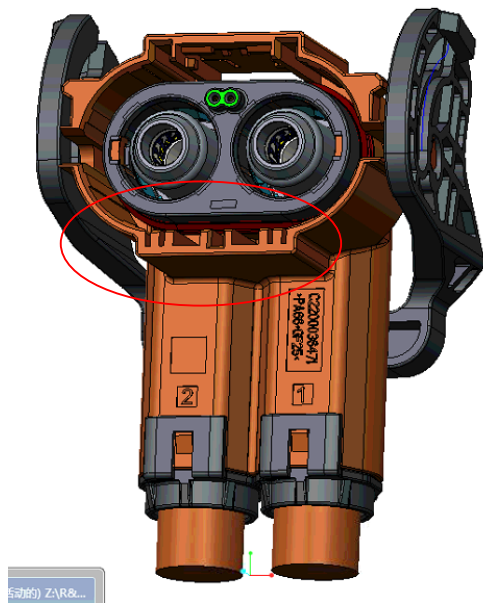

After change

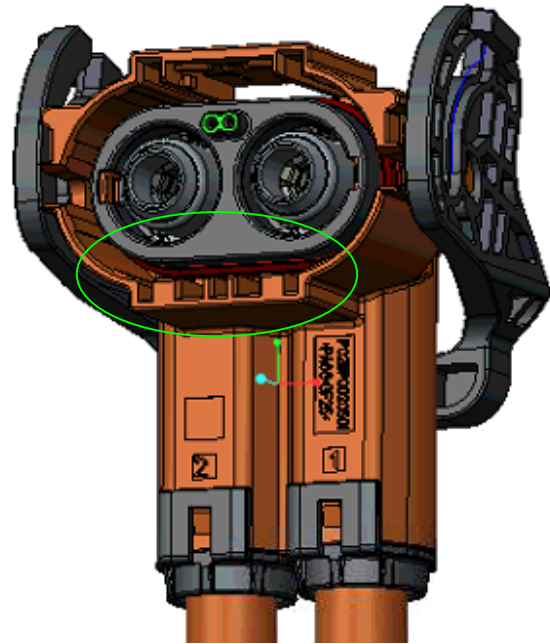

HVSL800082BXXX

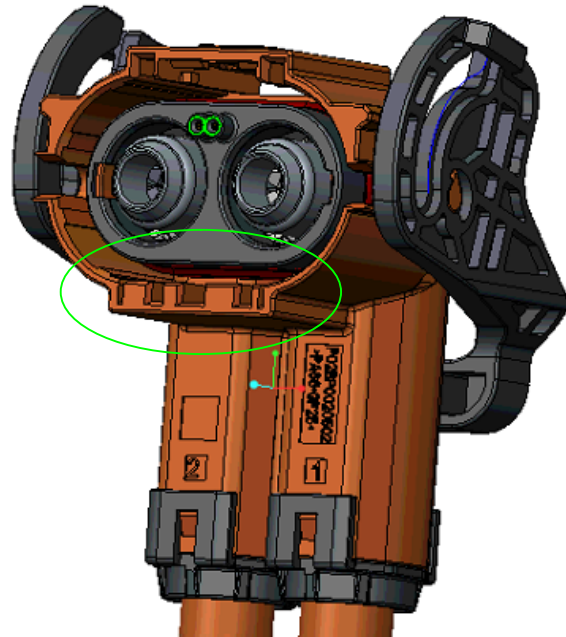
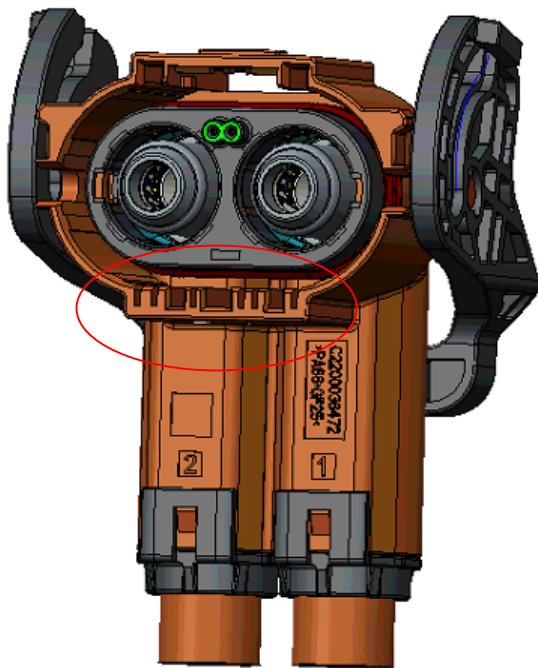

# Amphenol PCD

HVSL800082CXXX

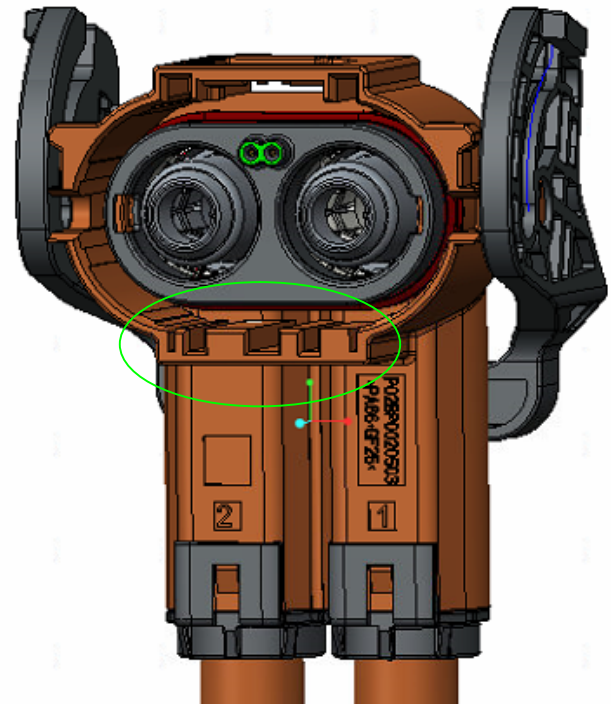
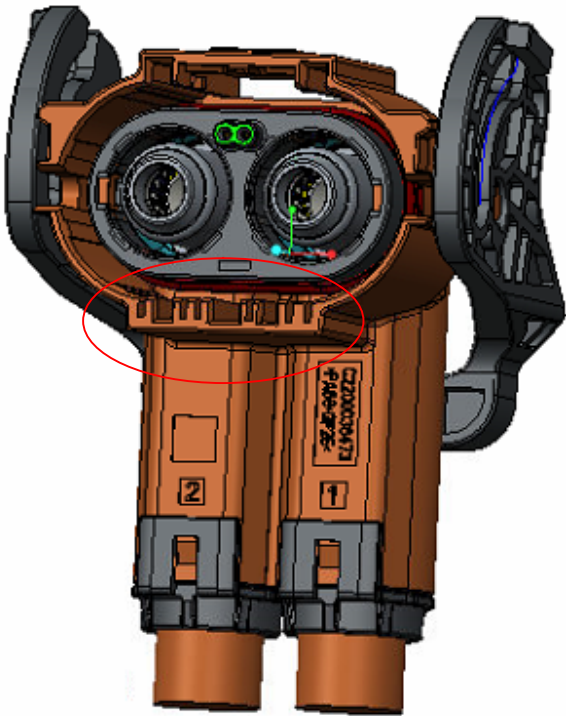

HVSLP800082AXXX

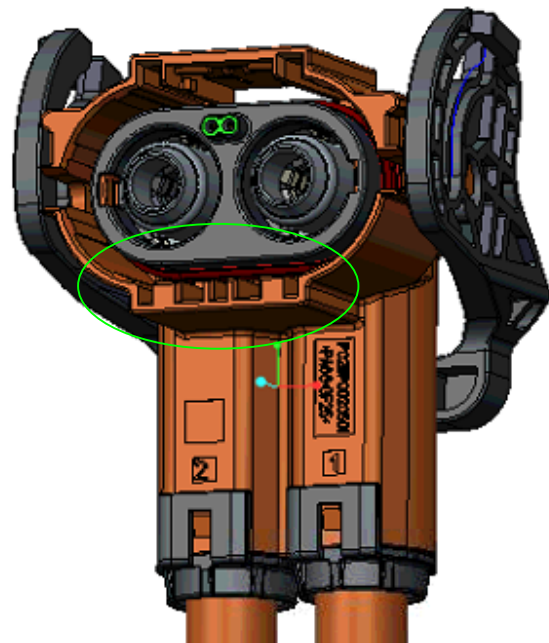
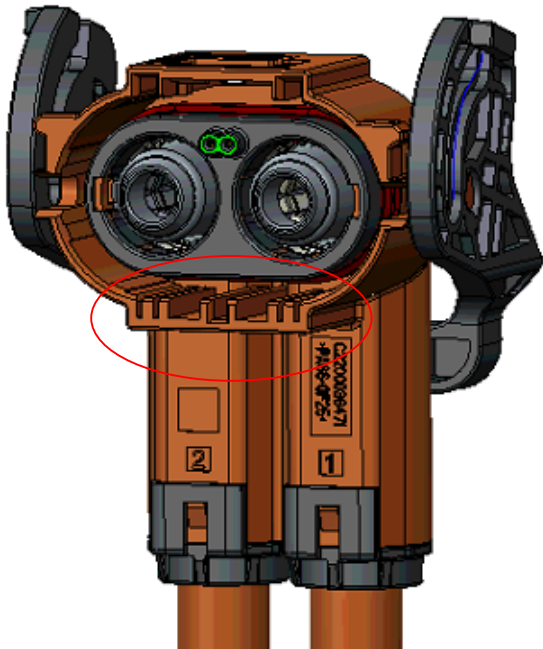

# Amphenol PCD

HVSLP800082BXXX

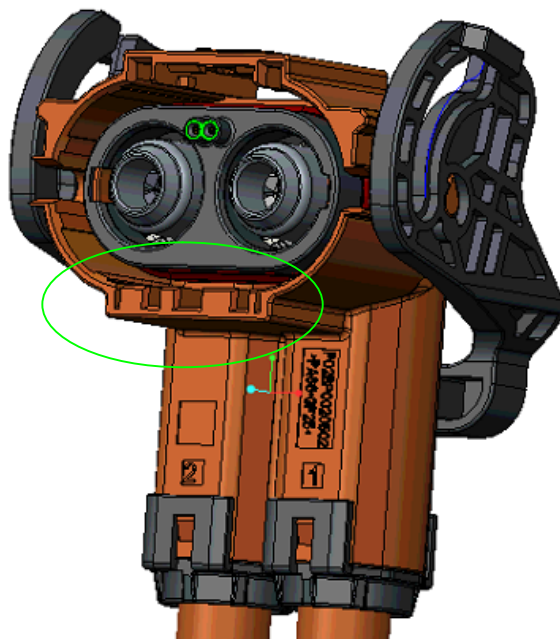
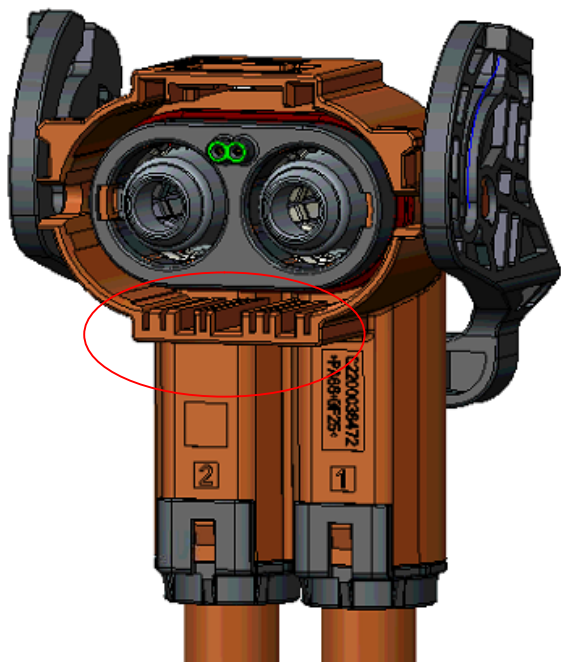

HVSLP800082CXXX

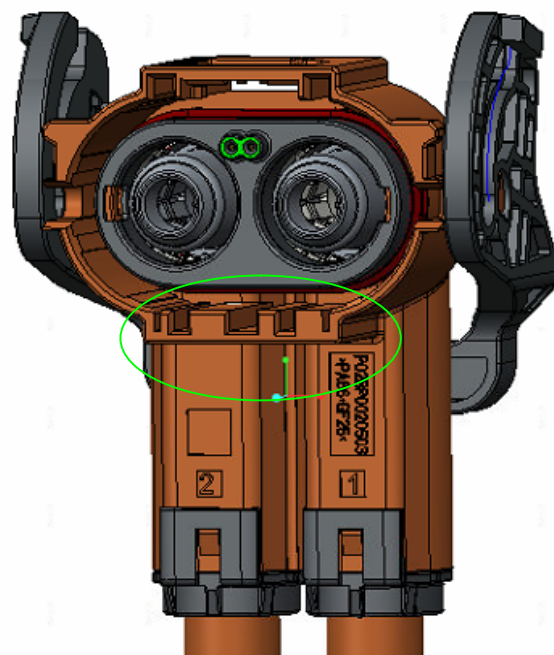
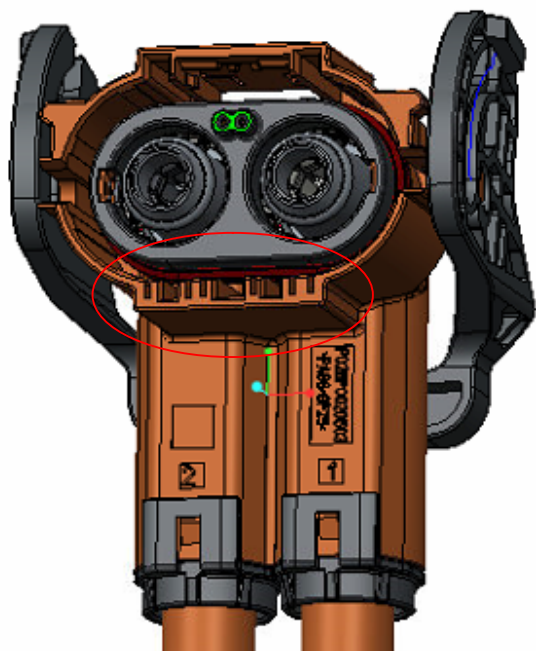

Disposition of old materials

Rework     Use as it is     scrap

Other (pls describe): \_\_\_\_\_

N/A

Expect date to switch to new material

2020.12.30

# Amphenol PCD

Approval by the manager of request dept.:

Customer approval:

Approved       No approved       Conditional approval (pls describe) :

Signature:

Date:

Remark: