

3600NF series

Sealed toggle switches
for outdoor applications



DISTINCTIVE FEATURES

- Sealed to IP67
- Solid silver contacts
- UL approved



ENVIRONMENTAL SPECIFICATIONS

- Sealing to IP67 according to IEC 60529 obtained by
 - O-ring between lever and bushing
 - half-length boot and nylon washer (supplied mounted)
 - elastomer gasket between cover and case
 - molded-in terminal inserts
 - sealing washer U60
- Operating temperature : -40 °C to +85 °C (-40 °F to +185 °F)



ELECTRICAL SPECIFICATIONS

- Max. current/voltage rating with resistive load : 12 A 28 VDC
- Initial contact resistance : 10 mΩ max.
- Insulation resistance : 1,000 MΩ min. at 500 VDC
- Dielectric strength :
 - 2,500 Vrms 50 Hz min. between terminals
 - 3,000 Vrms 50 Hz min. between terminals and frame
- Electrical life : 10,000 cycles at full load



GENERAL SPECIFICATIONS

- Torque : 1.50 Nm (1.10 Ft.lb) max. applied to nut
- Panel thickness : 2 mm (.079) max. with all accessories



MATERIALS

- Case : phenolic resin
- Actuator : brass, nickel plated
- Bushing : brass, nickel plated
- Contacts : solid silver

The company reserves the right to change specifications without notice.



3600NF series

Sealed toggle switches for outdoor applications

AGENCY APPROVAL



6 A 125 VAC/250 VAC

Availability : consult factory for details or approved models.

Marking : to order switches marked UL, complete last box of ordering format.



TERMINALS

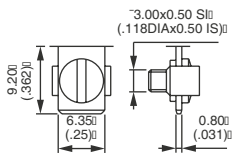

Screw

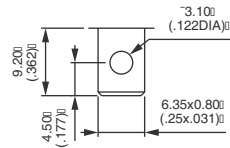

Solder lug / quick-connect



ELECTRICAL FUNCTIONS

→ KEYWAY

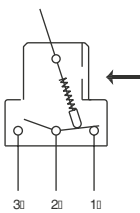

PANEL CUT-OUT

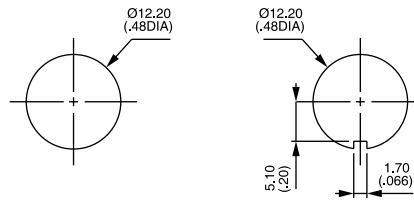

3600NF series

Sealed toggle switches for outdoor applications



BUILD YOUR PART NUMBER

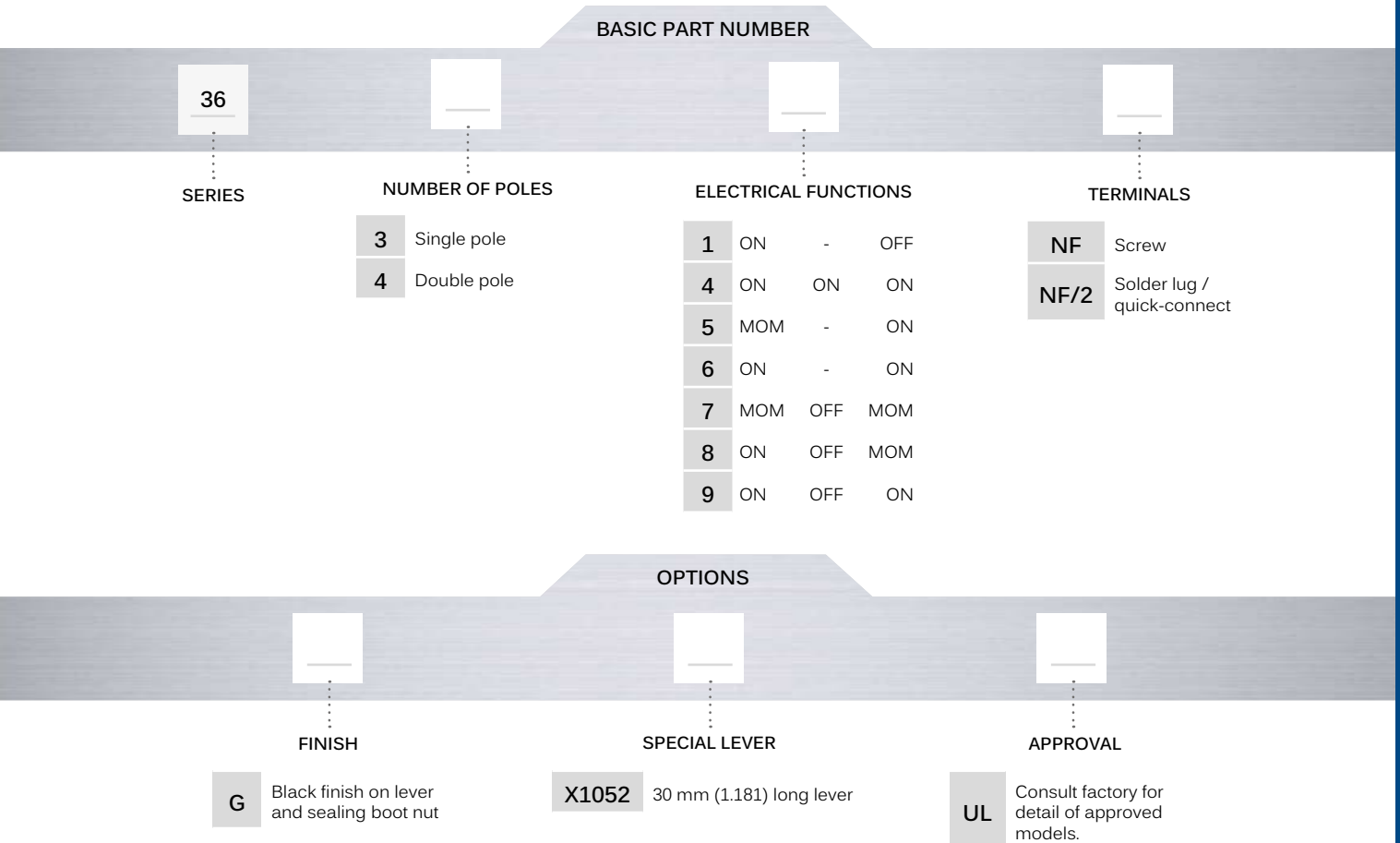

ABOUT THIS SERIES

On the following pages, you will find successively basic part numbers of switches and options in the same order as in above chart.

Notice : please note that not all combinations of above numbers are available. Refer to the following pages for further information.

Mounting accessories : 1 sealing boot U1151, 1 hex nut U166, 1 nylon washer U21 and 1 sealing washer U60. Standard and special hardware available is presented in the "Accessories" section of website.

3600NF series

Sealed toggle switches for outdoor applications

SCREW TERMINALS - SINGLE POLE



	III	II	I
	2-1	-	2-3
3631NF	ON	-	OFF
3635NF	MOM	-	ON
3636NF	ON	-	ON
3637NF	MOM	OFF	MOM
3638NF	ON	OFF	MOM
3639NF	ON	OFF	ON

→ KEYWAY

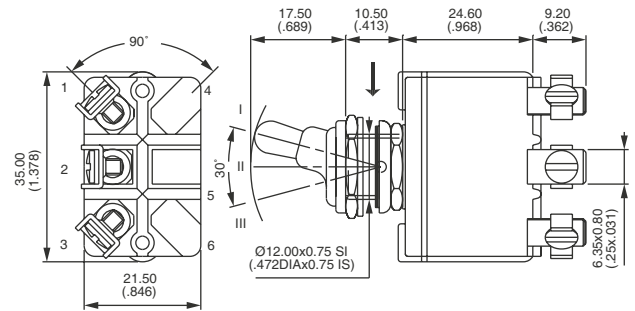

SCREW TERMINALS - DOUBLE POLE



	III	II	I
	2-1 5-4	-	2-3 5-6
3641NF	ON	-	OFF
3644NF *	ON	ON	ON
3645NF	MOM	-	ON
3646NF	ON	-	ON
3647NF	MOM	OFF	MOM
3648NF	ON	OFF	MOM
3649NF	ON	OFF	ON

→ KEYWAY

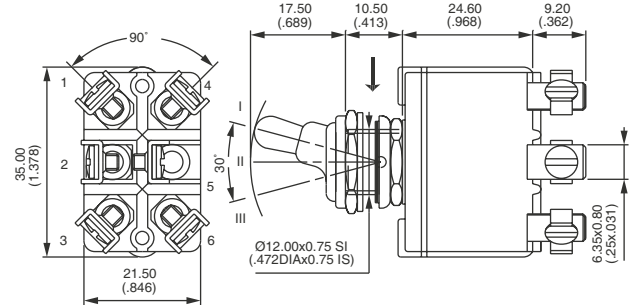

* Function 4 : SP in DP case, see "Technical information" on website

SOLDER LUG AND QUICK-CONNECT TERMINALS - SINGLE POLE



	III	II	I
	2-1	-	2-3
3631NF/2	ON	-	OFF
3635NF/2	MOM	-	ON
3636NF/2	ON	-	ON
3637NF/2	MOM	OFF	MOM
3638NF/2	ON	OFF	MOM
3639NF/2	ON	OFF	ON

→ KEYWAY

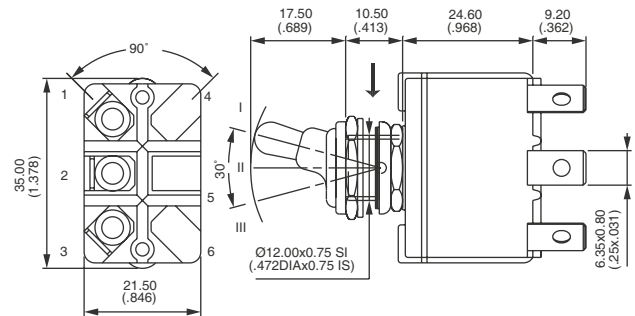

SOLDER LUG AND QUICK-CONNECT TERMINALS - DOUBLE POLE



	III	II	I
	2-1	-	2-3
3641NF/2	ON	-	OFF
3644NF/2*	ON	ON	ON
3645NF/2	MOM	-	ON
3646NF/2	ON	-	ON
3647NF/2	MOM	OFF	MOM
3648NF/2	ON	OFF	MOM
3649NF/2	ON	OFF	ON

→ KEYWAY

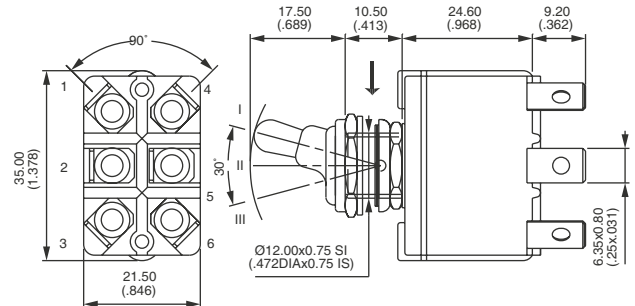

* Function 4 : SP in DP case, see "Technical information" on website

3600NF series

Sealed toggle switches for outdoor applications

FINISH



G Black finish on lever and nut of sealing boot

SPECIAL LEVER



X1052 30 mm (1.181) long lever

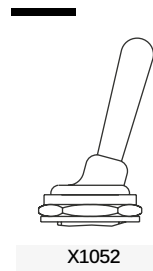

X1052

AGENCY APPROVAL



UL

Marking : to order switches marked UL, complete above box with "UL".