

Aufbau

Hutmutter	Messing CuZn39Pb3, galv. vernickelt
Lamelleneinsatz	Polyamid PA6 V-2
Dichtring	Polychloropren-Nitrilkautschuk CR/NBR
Zwischenstutzen	Messing CuZn39Pb3, galv. vernickelt
O-Ring	Nitrilkautschuk NBR
Anschlussgewinde	Pg, nach DIN 40430

Eigenschaften

	<ul style="list-style-type: none"> • für Kabel und Leitungen mit Schirmung • integrierte Zugentlastung • Verdrehenschutz • großer Dicht- und Klemmbereich
Temperaturbereich	-20°C +100°C
Schutzart	IP68 5bar

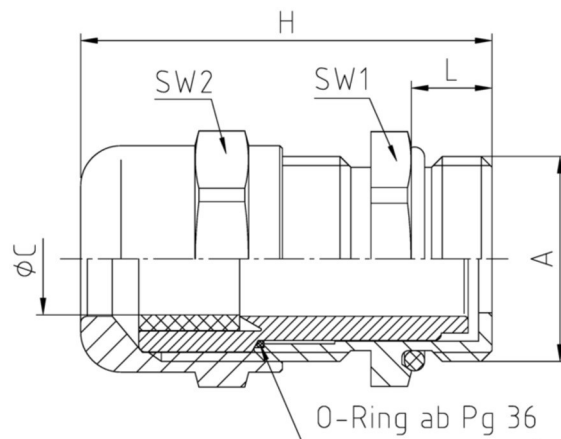

Merkmale

Anschlussgewinde Standardlänge

A	ØC	L	SW1	SW2	H		Art.-Nr.
	mm	mm	mm	mm	mm	Stück	
Pg 7	3 - 6,5	5	14	14	24	100	50.007/EMV
Pg 9	4 - 8	6	17	17	29	100	50.009/EMV
Pg 11	5 - 10	6	20	20	29,5	100	50.011/EMV
Pg 13,5	6 - 12	6,5	22	22	31,5	50	50.013/EMV
Pg 16	10 - 14	6,5	24	24	31,5 ¹	50	50.016/EMV
Pg 21	13 - 18	7	30	30	34	25	50.021/EMV
Pg 29	18 - 25	8	40	40	39	25	50.029/EMV

A	ØC	L	SW1	SW2	H		Art.-Nr.
	mm	mm	mm	mm	mm	Stück	
Pg 36	24 - 32	9	50	50	45	10	50.036/EMV
Pg 42	30 - 38	10	57	57	49	5	50.042/EMV
Pg 48	34 - 44	10	64	64	52	5	50.048/EMV