



USER MANUAL

EVALUATION BOARD FOR
WSEN-ISDS

2536030320091

VERSION 1.0

JANUARY 26, 2023

WÜRTH ELEKTRONIK MORE THAN YOU EXPECT

Revision history

Manual version	Product version	Notes	Date
1.0	1.0	<ul style="list-style-type: none">Initial release of the manual	January 2023

Abbreviations

Abbreviation	Description
I ² C	Inter integrated circuit
IMU	Inertial measurement unit
MEMS	Micro electro mechanical system
LSB	Least significant bit
SPI	Serial peripheral interface

Contents

1	General description	4
1.1	Introduction	4
1.2	Pin header compatibility	4
2	Functional description	5
2.1	Evaluation board in operation	7
2.1.1	I ² C connection (CON1)	7
2.1.2	SPI connection (CON2)	8
2.1.3	Resistor functionality	9
2.1.4	Through hole connection	10
3	Evaluation board	12
3.1	Schematic diagram	12
3.2	Layout	13
3.3	Bill of materials	14
4	Important notes	15
4.1	General customer responsibility	15
4.2	Customer responsibility related to specific, in particular safety-relevant applications	15
4.3	Best care and attention	15
4.4	Customer support for product specifications	15
4.5	Product improvements	16
4.6	Product life cycle	16
4.7	Property rights	16
4.8	General terms and conditions	16
5	Legal notice	17
5.1	Exclusion of liability	17
5.2	Suitability in customer applications	17
5.3	Usage restriction	17
6	License terms for Würth Elektronik eiSos GmbH & Co. KG sensor product software and source code	19
6.1	Limited license	19
6.2	Usage and obligations	19
6.3	Ownership	20
6.4	Disclaimer of warranty	20
6.5	Limitation of liability	20
6.6	Applicable law and jurisdiction	20
6.7	Severability clause	21
6.8	Miscellaneous	21

1 General description

1.1 Introduction

The evaluation board of the IMU (Inertial Measurement Unit) 6 axis sensor provides an opportunity to verify the sensor performance and develop a prototype using an extension board e.g. Sensor shield for Arduino (Part No. 2501000101291). It can be directly plugged to sensor shield using the mounted I²C and SPI interface pins. The evaluation board can also be mounted on a bread board using through hole pin header connections. The 6 axis IMU sensor (Part No: 2536030320091) is a 16-bit digital ultra-low-power and high-performance MEMS sensor. It includes 3 axis linear accelerometer and 3 axis gyroscope. The digital host interface offers either I²C or SPI to communicate with the sensor.

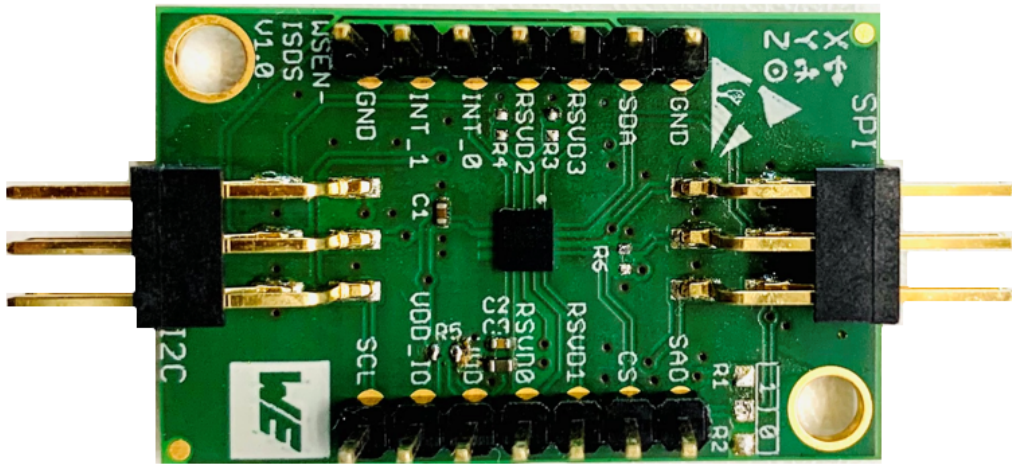

Figure 1: Evaluation board for the IMU 6 axis sensor

1.2 Pin header compatibility

6-pin right angle headers mounted on this evaluation board can be directly plugged into the sensor shield for Arduino or sensor FeatherWing. This serves a plug-and-play solution to quickly take the evaluation board into operation.



Sensor shield for Arduino is a stackable extension board for Arduino UNO and DUE to connect the sensor evaluation boards. More information can be found on our website.

2 Functional description

The acceleration sensor evaluation board supports the standard I²C and SPI communication interface. By default, I²C communication interface is enabled in the evaluation board.

- A positive supply voltage is applied to the sensor through *VDD* pin and I/O supply voltage for digital interface through *VDD_IO* pin. The *VDD* and *VDD_IO* pins on the board are connected together using 0Ω resistor R6.
- The I²C communication is enabled by connecting *CS* pin to *VDD_IO*. The *CS* pin is connected to *VDD_IO* using 100kΩ resistor R5.
- The 7-bit slave address of the acceleration sensor is 110101xb. LSB of the 7-bit slave address can be modified using the *SAO* pin.

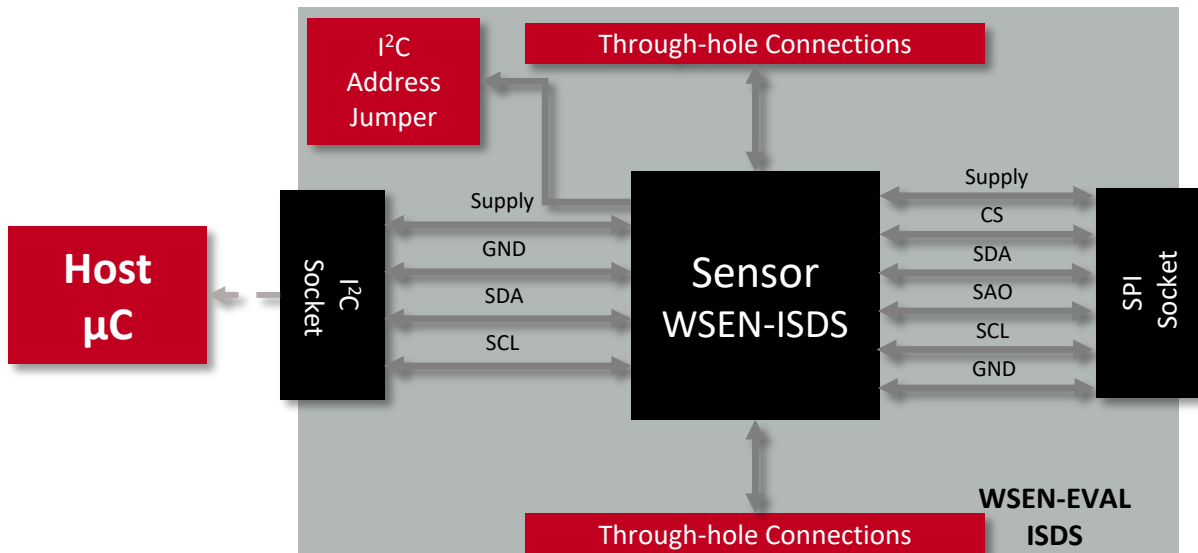

Figure 2: Block diagram of the evaluation board



By default the 7-bit slave address of the acceleration sensor on the evaluation board is 1101011b (0x6B). i.e. *SAO* pin of the sensor is connected to *VDD_IO* using 100kΩ resistor ADR.



The 7-bit slave address of the acceleration sensor can be changed to 1101010b (0x6A) by removing 100kΩ resistor ADR from '1' part and mounting 0Ω resistor on the '0' part of the evaluation board. i.e. *SAO* pin is connected to *GND*.



Please refer to the data sheet and user manual of the IMU 6 axis sensor (Part No: 2536030320001) for more information about the electrical properties.

2.1 Evaluation board in operation

2.1.1 I²C connection (CON1)

The pinning of connector CON1 provides I²C communication interface, which fits directly to the sensor shield for Arduino and sensor FeatherWing as mentioned in section 1.2. The I²C communication interface is the default state of the board.

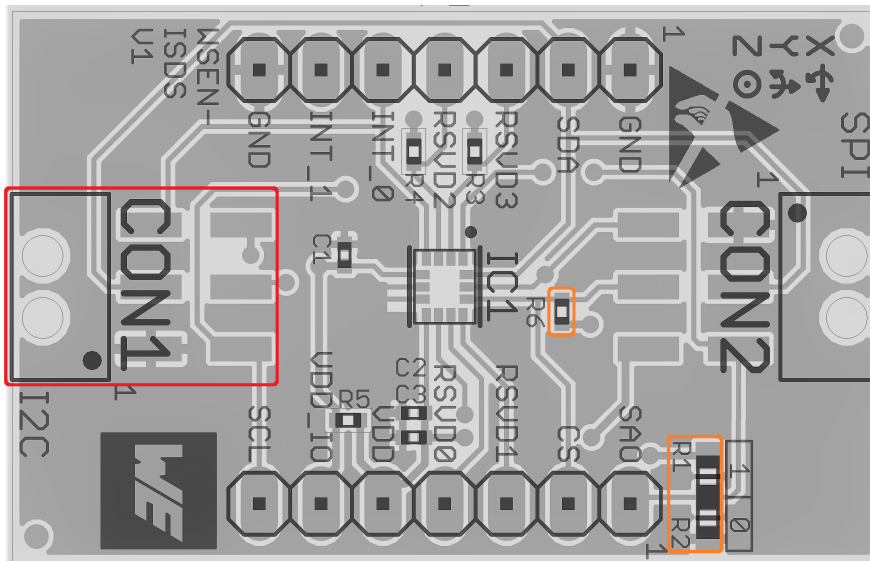
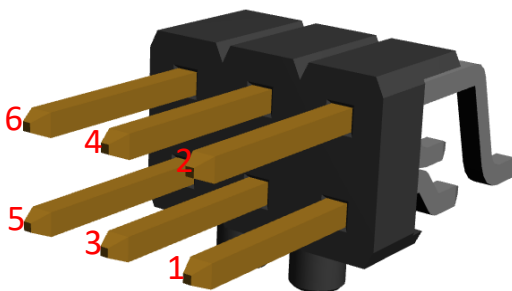

Figure 3: I²C Pin header connection to the external boards



Pin No	I ² C Pins (CON1)
1	<i>GND</i>
2	<i>SCL</i>
3	<i>SDA</i>
4	<i>INT_1</i>
5	<i>INT_0</i>
6	<i>VDD</i>

Table 1: I²C Pin header



R6 shall be populated to enable I²C communication.



Either R1 or R2 shall be populated to define the LSB of sensor's address.



Connecting the sensor evaluation board to the sensor FeatherWing using I²C or SPI interface pins will disable INT_0 and INT_1 interrupt pin functions.

2.1.2 SPI connection (CON2)

The pinning of connector CON2 provides SPI communication interface, which fits directly to the sensor shield for Arduino and sensor FeatherWing as mentioned in section 1.2.

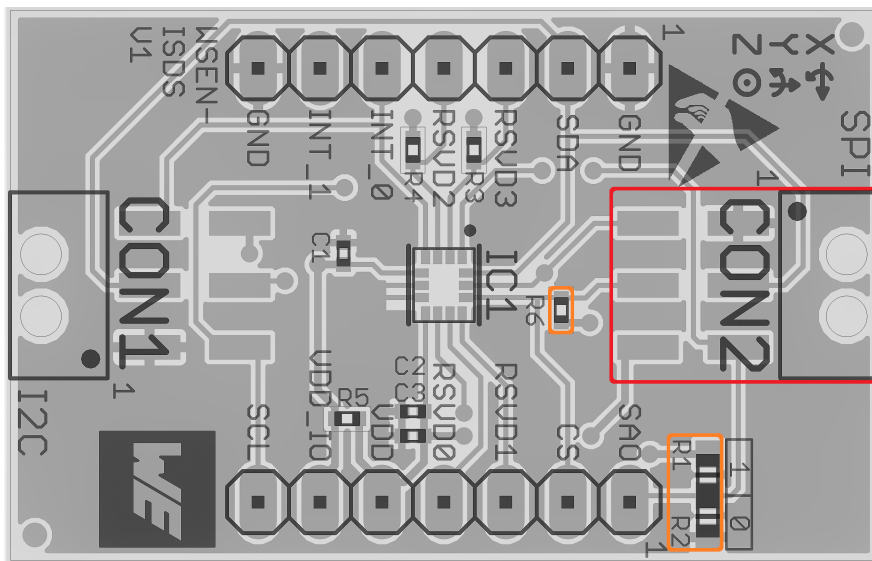
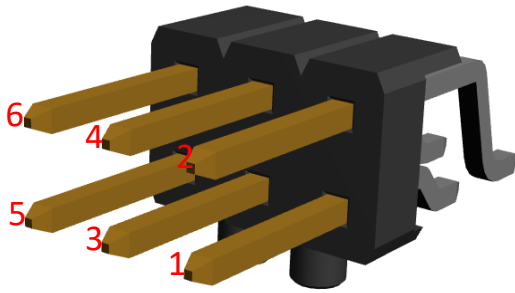

Figure 4: SPI Pin header connection



Pin No	SPI Pins (CON2)
1	<i>GND</i>
2	<i>SCL</i>
3	<i>SDA (MOSI)</i>
4	<i>CS</i>
5	<i>SAO (MISO)</i>
6	<i>VDD</i>

Table 2: SPI Pin header to external boards



SPI communication is enabled by removing the R1, R2, and R6 resistors.

2.1.3 Resistor functionality

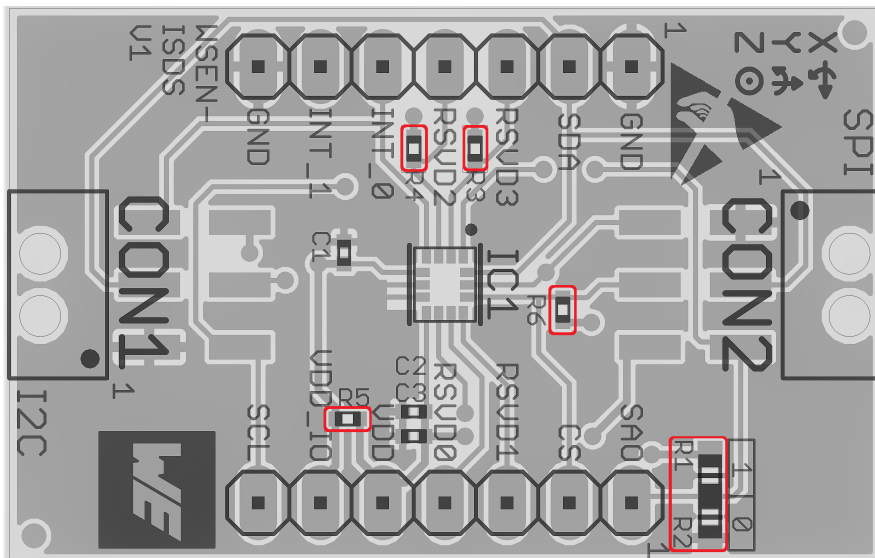

Figure 5: Resistor functionality

Resistor	Description
R1, R2	R1 is by default populated. SAO is connected to the VDD_IO, therefore the I ² C address of sensor is 1101011b. If R2 is assembled the the I ² C address of sensor is 1101010b.
R3, R4	Reserved functionality. Do not remove.
R5	VDD and VDD_IO pins are connected together.
R6	I ² C enabled by default. CS is connected to VDD_IO. To enable SPI communication, remove R1, R2 and R6 resistors.

Table 3: Functionality of the resistors on the evaluation board



Check in your configuration, if the resistors R1, R2 and R6 have to be removed before connecting the evaluation board to a processor.

2.1.4 Through hole connection

Through hole pin headers connection gives direct access to each sensor pin. Please refer to table 4 and 5 for the pin description of P1 and P2 respectively.

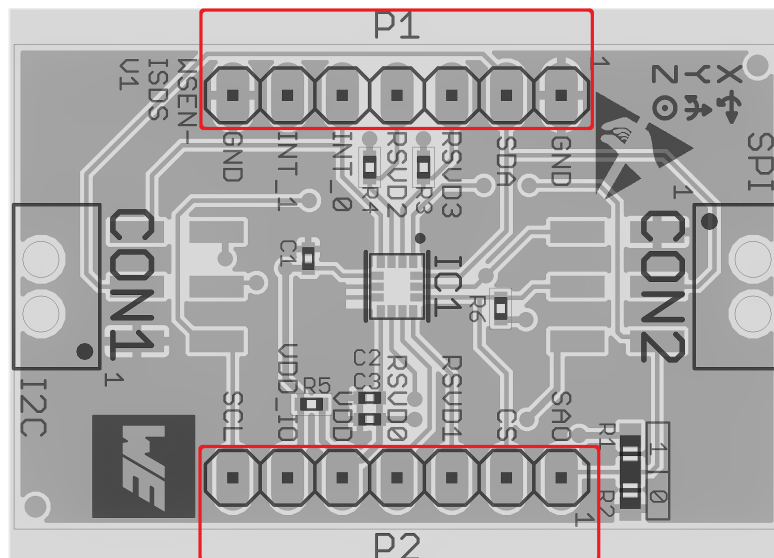

Figure 6: Through hole connection P1 and P2

Pin No.	Evaluation board pins	Description	Input/Output
1	<i>GND</i>	Negative supply voltage	Supply
2	<i>SDA</i>	I ² C serial data, SPI serial data input	Input/Output
3	<i>RSVD3</i>	Reserve functionality. Corresponds to sensor's pin 2	Input/Output
4	<i>RSVD2</i>	Reserve functionality. Corresponds to sensor's pin 3	Input/Output
5	<i>INT_0</i>	Interrupt pin 0	Output
6	<i>INT_1</i>	Interrupt pin 1	Output
7	<i>GND</i>	Negative supply voltage	Supply

Table 4: Pin description of P1

Pin No.	Evaluation board pins	Description	Input/Output
1	<i>SAO</i>	I ² C device address selection, SPI serial data output	Input/output
2	<i>CS</i>	I ² C enable/disable, SPI chip select	Input
3	<i>RSVD1</i>	Reserved functionality. Corresponds to sensor's pin 11	Input/Output
4	<i>RSVD0</i>	Reserved functionality. Corresponds to sensor's pin 10	Input/Output
5	<i>VDD</i>	Positive supply voltage	Supply
6	<i>VDD_IO</i>	Positive supply voltage for I/O pins	Supply
7	<i>SCL</i>	I ² C/SPI serial clock	Input

Table 5: Pin description of P2

3 Evaluation board

3.1 Schematic diagram

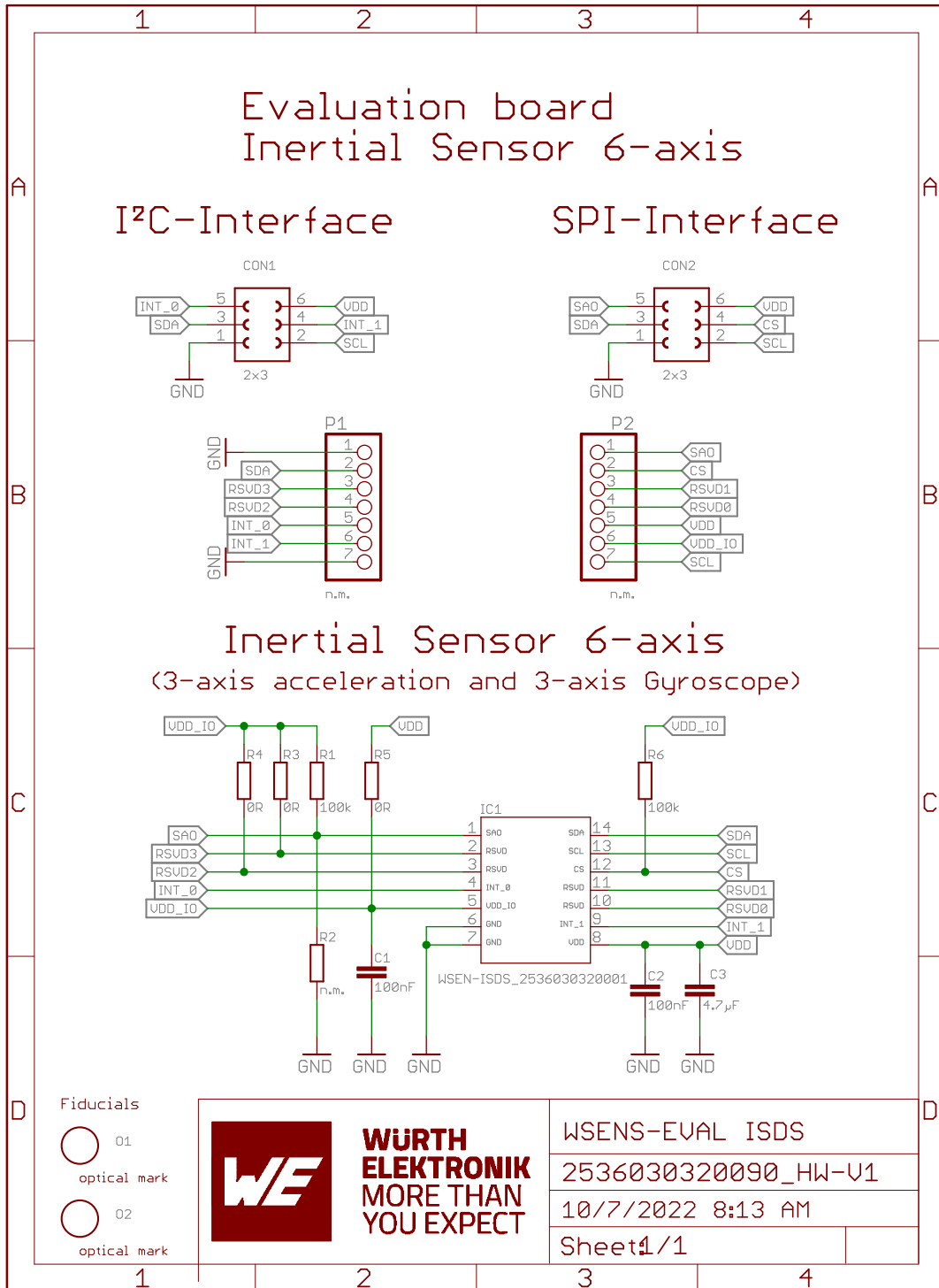

Figure 7: Schematic diagram

3.2 Layout

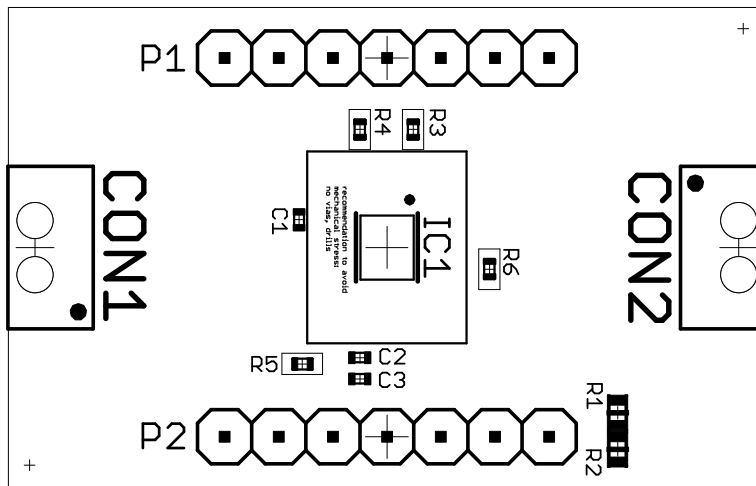

Figure 8: Assembly diagram

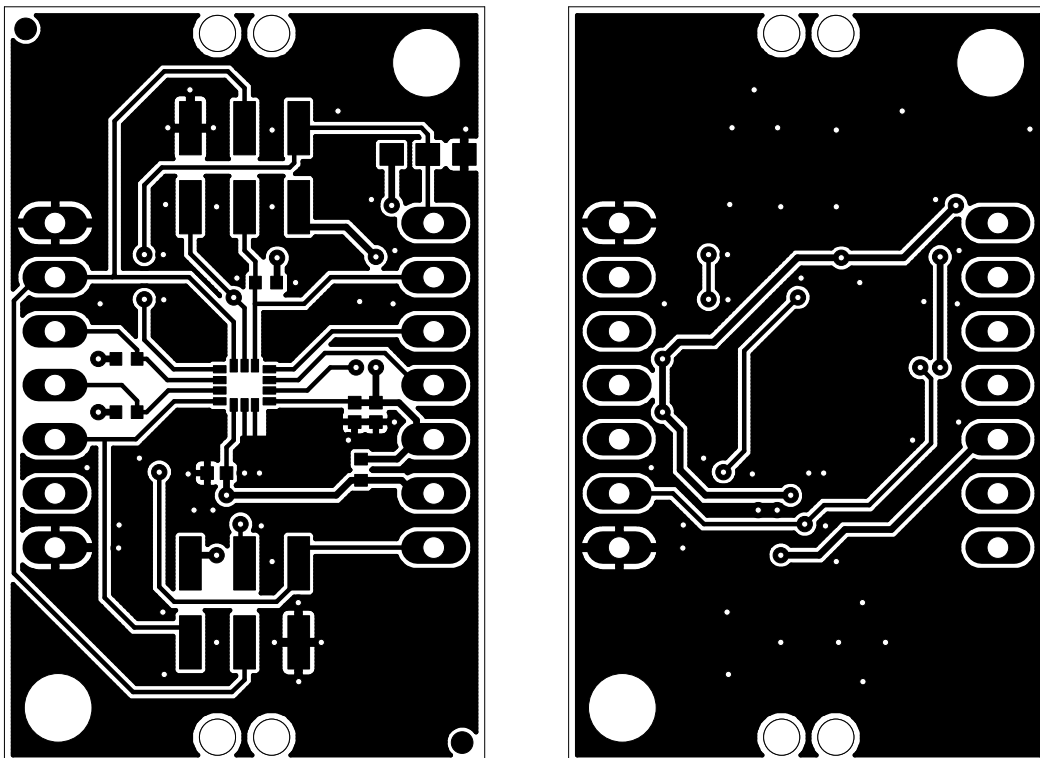

Figure 9: Top (left) and bottom (right) layers

3.3 Bill of materials

Part	Value	Pack	Manufacturer	NR
C1	100 nF	0402	Würth Elektronik eiSos	885012205037
C2	100 nF	0402	Würth Elektronik eiSos	885012205037
C3	4.7 μ F	0402	Würth Elektronik eiSos	885012105008
CON1	2x3	THT	Würth Elektronik eiSos	610106249121
CON2	2x3	THT	Würth Elektronik eiSos	610106249121
IC1	WSEN-ISDS	SMT	Würth Elektronik eiSos	2536030320001
P1	n.m.	SMT	n.m.	n.m.
P2	n.m.	SMT	n.m.	n.m.
R1	100 k Ω	0603	Yageo	RC0603FR-10100KL
R2	n.m.	SMT	n.m.	n.m.
R3	0 Ω	0402	Yageo	RC0402FR-070RL
R4	0 Ω	0402	Yageo	RC0402FR-070RL
R5	0 Ω	0402	Yageo	RC0402FR-070RL
R6	100 k Ω	0402	Yageo	RC0402FR-07100KL

Table 6: Bill of materials

4 Important notes

The following conditions apply to all goods within the sensors product range of Würth Elektronik eiSos GmbH & Co. KG:

4.1 General customer responsibility

Some goods within the product range of Würth Elektronik eiSos GmbH & Co. KG contain statements regarding general suitability for certain application areas. These statements about suitability are based on our knowledge and experience of typical requirements concerning the areas, serve as general guidance and cannot be estimated as binding statements about the suitability for a customer application. The responsibility for the applicability and use in a particular customer design is always solely within the authority of the customer. Due to this fact, it is up to the customer to evaluate, where appropriate to investigate and to decide whether the device with the specific product characteristics described in the product specification is valid and suitable for the respective customer application or not. Accordingly, the customer is cautioned to verify that the documentation is current before placing orders.

4.2 Customer responsibility related to specific, in particular safety-relevant applications

It has to be clearly pointed out that the possibility of a malfunction of electronic components or failure before the end of the usual lifetime cannot be completely eliminated in the current state of the art, even if the products are operated within the range of the specifications. The same statement is valid for all software and software parts contained in or used with or for products in the sensor product range of Würth Elektronik eiSos GmbH & Co. KG. In certain customer applications requiring a high level of safety and especially in customer applications in which the malfunction or failure of an electronic component could endanger human life or health, it must be ensured by most advanced technological aid of suitable design of the customer application that no injury or damage is caused to third parties in the event of malfunction or failure of an electronic component.

4.3 Best care and attention

Any product-specific data sheets, manuals, application notes, PCN's, warnings and cautions must be strictly observed in the most recent versions and matching to the products revisions. This documents can be downloaded from the product specific sections on the wireless connectivity and sensors homepage.

4.4 Customer support for product specifications

Some products within the product range may contain substances, which are subject to restrictions in certain jurisdictions in order to serve specific technical requirements. Necessary information is available on request. In this case, the field sales engineer or the internal sales person in charge should be contacted who will be happy to support in this matter.

4.5 Product improvements

Due to constant product improvement, product specifications may change from time to time. As a standard reporting procedure of the Product Change Notification (PCN) according to the JEDEC-Standard, we inform about major changes. In case of further queries regarding the PCN, the field sales engineer, the internal sales person or the technical support team in charge should be contacted. The basic responsibility of the customer as per section 4.1 and 4.2 remains unaffected.

The sensor driver software "Sensor SDK" and its source codes are not subject to the Product Change Notification information process.

4.6 Product life cycle

Due to technical progress and economical evaluation we also reserve the right to discontinue production and delivery of products. As a standard reporting procedure of the Product Termination Notification (PTN) according to the JEDEC-Standard we will inform at an early stage about inevitable product discontinuance. According to this, we cannot ensure that all products within our product range will always be available. Therefore, it needs to be verified with the field sales engineer or the internal sales person in charge about the current product availability expectancy before or when the product for application design-in disposal is considered. The approach named above does not apply in the case of individual agreements deviating from the foregoing for customer-specific products.

4.7 Property rights

All the rights for contractual products produced by Würth Elektronik eiSos GmbH & Co. KG on the basis of ideas, development contracts as well as models or templates that are subject to copyright, patent or commercial protection supplied to the customer will remain with Würth Elektronik eiSos GmbH & Co. KG. Würth Elektronik eiSos GmbH & Co. KG does not warrant or represent that any license, either expressed or implied, is granted under any patent right, copyright, mask work right, or other intellectual property right relating to any combination, application, or process in which Würth Elektronik eiSos GmbH & Co. KG components or services are used.

4.8 General terms and conditions

Unless otherwise agreed in individual contracts, all orders are subject to the current version of the "General Terms and Conditions of Würth Elektronik eiSos Group", last version available at www.we-online.com.

5 Legal notice

5.1 Exclusion of liability

Würth Elektronik eiSos GmbH & Co. KG considers the information in this document to be correct at the time of publication. However, Würth Elektronik eiSos GmbH & Co. KG reserves the right to modify the information such as technical specifications or functions of its products or discontinue the production of these products or the support of one of these products without any written announcement or notification to customers. The customer must make sure that the information used corresponds to the latest published information. Würth Elektronik eiSos GmbH & Co. KG does not assume any liability for the use of its products. Würth Elektronik eiSos GmbH & Co. KG does not grant licenses for its patent rights or for any other of its intellectual property rights or third-party rights.

Notwithstanding anything above, Würth Elektronik eiSos GmbH & Co. KG makes no representations and/or warranties of any kind for the provided information related to their accuracy, correctness, completeness, usage of the products and/or usability for customer applications. Information published by Würth Elektronik eiSos GmbH & Co. KG regarding third-party products or services does not constitute a license to use such products or services or a warranty or endorsement thereof.

5.2 Suitability in customer applications

The customer bears the responsibility for compliance of systems or units, in which Würth Elektronik eiSos GmbH & Co. KG products are integrated, with applicable legal regulations. Customer acknowledges and agrees that it is solely responsible for compliance with all legal, regulatory and safety-related requirements concerning its products, and any use of Würth Elektronik eiSos GmbH & Co. KG components in its applications, notwithstanding any applications-related information or support that may be provided by Würth Elektronik eiSos GmbH & Co. KG. Customer represents and agrees that it has all the necessary expertise to create and implement safeguards which anticipate dangerous consequences of failures, monitor failures and their consequences lessen the likelihood of failures that might cause harm and take appropriate remedial actions. The customer will fully indemnify Würth Elektronik eiSos GmbH & Co. KG and its representatives against any damages arising out of the use of any Würth Elektronik eiSos GmbH & Co. KG components in safety-critical applications.

5.3 Usage restriction

Würth Elektronik eiSos GmbH & Co. KG products have been designed and developed for use in general electronic equipment only. This product is not authorized for use in equipment where a higher safety standard and reliability standard is especially required or where a failure of the product is reasonably expected to cause severe personal injury or death, unless the parties have executed an agreement specifically governing such use. Moreover, Würth Elektronik eiSos GmbH & Co. KG products are neither designed nor intended for use in areas such as military, aerospace, aviation, nuclear control, submarine, transportation (automotive control, train control, ship control), transportation signal, disaster prevention, medical, public information network etc. Würth Elektronik eiSos GmbH & Co. KG must be informed about the intent

of such usage before the design-in stage. In addition, sufficient reliability evaluation checks for safety must be performed on every electronic component, which is used in electrical circuits that require high safety and reliability function or performance. By using Würth Elektronik eiSos GmbH & Co. KG products, the customer agrees to these terms and conditions.

6 License terms for Würth Elektronik eiSos GmbH & Co. KG sensor product software and source code

This License terms will take effect upon the purchase and usage of the Würth Elektronik eiSos GmbH & Co. KG sensor products. You hereby agree that this license terms are applicable to the product and the incorporated software, firmware and source codes (collectively, "Software") made available by Würth Elektronik eiSos in any form, including but not limited to binary, executable or source code form.

The software included in any Würth Elektronik eiSos sensor product is purchased to you on the condition that you accept the terms and conditions of this license terms. You agree to comply with all provisions under this license terms.

6.1 Limited license

Würth Elektronik eiSos hereby grants you a limited, non-exclusive, non-transferable and royalty-free license to use the software and under the conditions that will be set forth in this license terms. You are free to use the provided software only in connection with one of the products from Würth Elektronik eiSos to the extent described in this license terms.

You are entitled to change or alter the source code for the sole purpose of creating an application embedding the Würth Elektronik eiSos sensor product. The transfer of the source code to third parties is allowed to the sole extent that the source code is used by such third parties in connection with our product or another hardware provided by Würth Elektronik eiSos under strict adherence of this license terms. Würth Elektronik eiSos will not assume any liability for the usage of the incorporated software and the source code.

You are not entitled to transfer the source code in any form to third parties without prior written consent of Würth Elektronik eiSos.

You are not allowed to reproduce, translate, reverse engineer, decompile, disassemble or create derivative works of the incorporated software and the source code in whole or in part.

No more extensive rights to use and exploit the products are granted to you.

6.2 Usage and obligations

The responsibility for the applicability and use of the Würth Elektronik eiSos sensor product with the incorporated software in a particular customer design is always solely within the authority of the customer. Due to this fact, it is up to you to evaluate and investigate, where appropriate, and to decide whether the device with the specific product characteristics described in the product specification is valid and suitable for your respective application or not.

You are responsible for using the Würth Elektronik eiSos sensor product with the incorporated software in compliance with all applicable product liability and product safety laws. You acknowledge to minimize the risk of loss and harm to individuals and bear the risk for failure leading to personal injury or death due to your usage of the product.

Würth Elektronik eiSos' products are not authorized for use in safety-critical applications, or where a failure of the product is reasonably expected to cause severe personal injury or death. Moreover, Würth Elektronik eiSos' products are neither designed nor intended for use in areas such as military, aerospace, aviation, nuclear control, submarine, transportation (automotive

control, train control, ship control), transportation signal, disaster prevention, medical, public information network etc. You shall inform Würth Elektronik eiSos about the intent of such usage before design-in stage. In certain customer applications requiring a very high level of safety and in which the malfunction or failure of an electronic component could endanger human life or health, you must ensure to have all necessary expertise in the safety and regulatory ramifications of your applications. You acknowledge and agree that you are solely responsible for all legal, regulatory and safety-related requirements concerning your products and any use of Würth Elektronik eiSos' products in such safety-critical applications, notwithstanding any applications-related information or support that may be provided by Würth Elektronik eiSos. YOU SHALL INDEMNIFY WÜRTH ELEKTRONIK EISOS AGAINST ANY DAMAGES ARISING OUT OF THE USE OF WÜRTH ELEKTRONIK EISOS' PRODUCTS IN SUCH SAFETY-CRITICAL APPLICATIONS.

6.3 Ownership

The incorporated Software created by Würth Elektronik eiSos is and will remain the exclusive property of Würth Elektronik eiSos.

6.4 Disclaimer of warranty

THE SOFTWARE AND IT'S SOURCE CODE IS PROVIDED "AS IS". YOU ACKNOWLEDGE THAT WÜRTH ELEKTRONIK EISOS MAKES NO REPRESENTATIONS AND WARRANTIES OF ANY KIND RELATED TO, BUT NOT LIMITED TO THE NON-INFRINGEMENT OF THIRD PARTIES' INTELLECTUAL PROPERTY RIGHTS OR THE MERCHANTABILITY OR FITNESS FOR YOUR INTENDED PURPOSE OR USAGE. WÜRTH ELEKTRONIK EISOS DOES NOT WARRANT OR REPRESENT THAT ANY LICENSE, EITHER EXPRESS OR IMPLIED, IS GRANTED UNDER ANY PATENT RIGHT, COPYRIGHT, MASK WORK RIGHT, OR OTHER INTELLECTUAL PROPERTY RIGHT RELATING TO ANY COMBINATION, MACHINE, OR PROCESS IN WHICH THE WÜRTH ELEKTRONIK EISOS' PRODUCT WITH THE INCORPORATED SOFTWARE IS USED. INFORMATION PUBLISHED BY WÜRTH ELEKTRONIK EISOS REGARDING THIRD-PARTY PRODUCTS OR SERVICES DOES NOT CONSTITUTE A LICENSE FROM WÜRTH ELEKTRONIK EISOS TO USE SUCH PRODUCTS OR SERVICES OR A WARRANTY OR ENDORSEMENT THEREOF.

6.5 Limitation of liability

Any liability not expressly provided by Würth Elektronik eiSos shall be disclaimed. You agree to hold us harmless from any third-party claims related to your usage of the Würth Elektronik eiSos' products with the incorporated software and source code. Würth Elektronik eiSos disclaims any liability for any alteration, development created by you or your customers as well as for any combination with other products.

6.6 Applicable law and jurisdiction

Applicable law to this license terms shall be the laws of the Federal Republic of Germany. Any dispute, claim or controversy arising out of or relating to this license terms shall be resolved

and finally settled by the court competent for the location of Würth Elektronik eiSos registered office.

6.7 Severability clause

If a provision of this license terms are or becomes invalid, unenforceable or null and void, this shall not affect the remaining provisions of the terms. The parties shall replace any such provisions with new valid provisions that most closely approximate the purpose of the terms.

6.8 Miscellaneous

Würth Elektronik eiSos reserves the right at any time to change this terms at its own discretion. It is your responsibility to check at Würth Elektronik eiSos homepage for any updates. Your continued usage of the products will be deemed as the acceptance of the change.

We recommend you to be updated about the status of new software, which is available on our website or in our data sheet, and to implement new software in your device where appropriate. By ordering a sensor product, you accept this license terms in all terms.

List of Figures

1	Evaluation board for the IMU 6 axis sensor	4
2	Block diagram of the evaluation board	5
3	I ² C Pin header connection to the external boards	7
4	SPI Pin header connection	8
5	Resistor functionality	9
6	Through hole connection P1 and P2	10
7	Schematic diagram	12
8	Assembly diagram	13
9	Top (left) and bottom (right) layers	13

List of Tables

1	I ² C Pin header	7
2	SPI Pin header to external boards	8
3	Functionality of the resistors on the evaluation board	9
4	Pin description of P1	10
5	Pin description of P2	11
6	Bill of materials	14



Contact

Würth Elektronik eiSos GmbH & Co. KG
Division Wireless Connectivity & Sensors

Max-Eyth-Straße 1
74638 Waldenburg
Germany

Tel.: +49 651 99355-0
Fax.: +49 651 99355-69
www.we-online.com/wireless-connectivity

WÜRTH ELEKTRONIK MORE THAN YOU EXPECT