

DURACELL®

76A/LR44

Zinc/Manganese Dioxide Battery

Zn/MnO₂

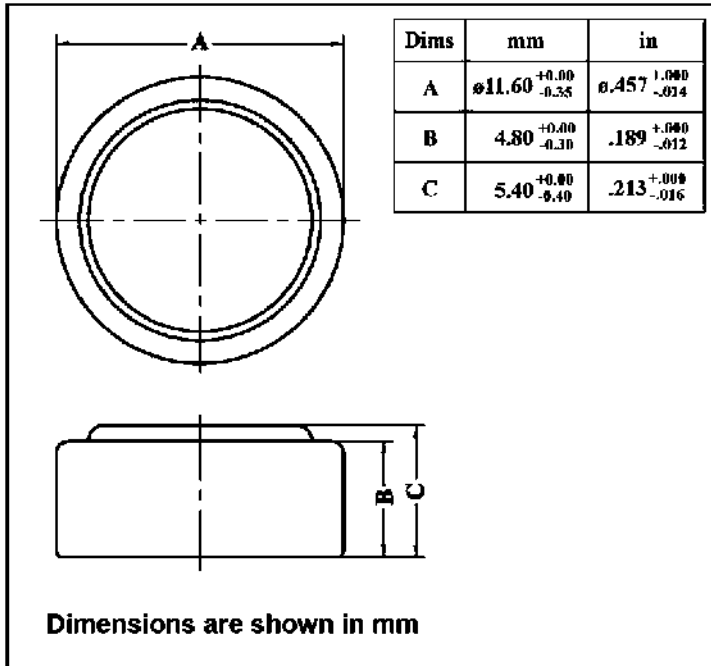

SPECIFICATIONS

Nominal Voltage:	1.5 V
Rated Capacity:	105 mAh on 6.8 kΩ to 1.2 V
Average Weight:	1.98 g (0.070 oz.)
Terminals:	Flat
Operating Temp. Range:	-20°C – 54°C (-4°F – 130°F)
NEDA/ANSI:	1166A
IEC:	LR44

Discharge Characteristics

6.8 kΩ load for 24 hrs/day to 1.2V

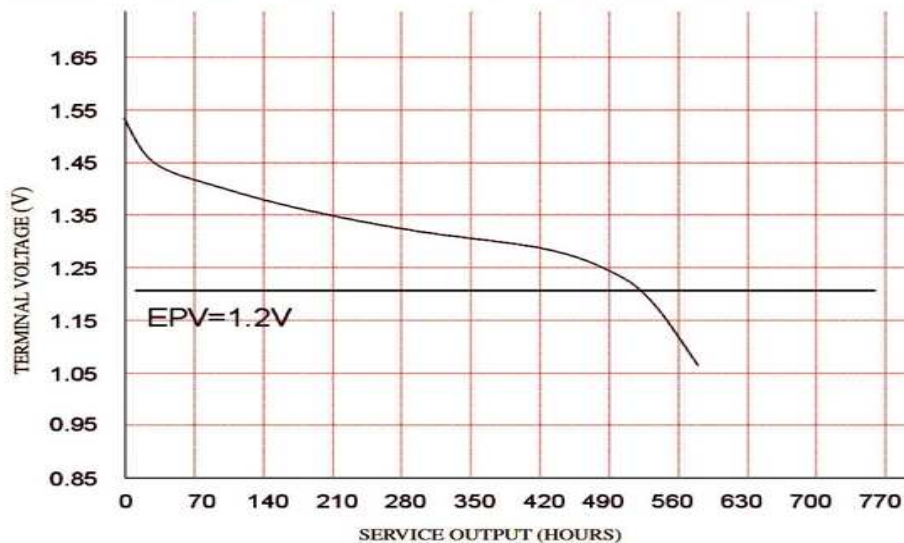

DURACELL®

BATTERIES

Berkshire Corporate Park Bethel,
CT. 06801 U.S.A.
Telephone: Toll-free 1-800-544-5454
www.duracell.com

Delivered capacity is dependent on the applied load, operating temperature and cut-off voltage. Please refer to the charts and discharge data shown for examples of the energy/service life that the battery will provide for various load conditions.