



Figure similar

LOAD FEEDER FUSELESS REVERSING OPERATION, AC 400V, SZ. S00, 1.4 ... 2A 24 V DC SCREW CONNECTION FOR MOUNTING ON STANDARD RAIL, TYPE OF COORDINATION 2,IQ = 150KA ALSO FULFILLS TYPE OF COORDINATION 1) 1NC (CONTACTOR) 2NO+2NC PLUGGED ONTO CONTACTOR 1NO+1NC (CIRCUIT BREAKER, TRANSVERSE)

product brand name	SIRIUS
Product designation	non-fused load feeders 3RA2
<b>Manufacturer article number</b>	
<ul style="list-style-type: none"> <li>• of the supplied contactor</li> <li>• of the supplied circuit-breakers</li> <li>• of the supplied link module</li> </ul>	<a href="#">3RT2016-1BB44</a> <a href="#">3RV2011-1BA15</a> <a href="#">3RA1921-1DA00</a>

### General technical data:

<b>Insulation voltage</b>		
<ul style="list-style-type: none"> <li>• with degree of pollution 3 Rated value</li> </ul>	V	690
<b>Shock resistance</b>		
<ul style="list-style-type: none"> <li>• acc. to IEC 60068-2-27</li> </ul>		6g / 11 ms
<b>Surge voltage resistance Rated value</b>	kV	6
<b>Type of assignment</b>		2
<b>Protection class IP</b>		
<ul style="list-style-type: none"> <li>• on the front</li> </ul>		IP20

### Main circuit:

<b>Number of poles for main current circuit</b>		3
<b>Adjustable response value current of the current-dependent overload release</b>	A	1.4 ... 2
<b>Operating voltage</b>		
<ul style="list-style-type: none"> <li>• Rated value</li> <li>• at AC-3 Rated value maximum</li> </ul>	V	690
	V	690
<b>Operating frequency Rated value</b>	Hz	50 ... 60
<b>Operating current</b>		
<ul style="list-style-type: none"> <li>• at AC-3</li> </ul>		

— at 400 V Rated value	A	1.9
<b>Operating power</b>		
• at AC-3		
— at 400 V Rated value	W	750
— at 500 V Rated value	W	750
— at 690 V Rated value	W	1 100

#### Control circuit/ Control:

<b>Control supply voltage for DC</b>		
• Rated value	V	24
<b>Holding power of the magnet coil for DC</b>	W	4

#### Auxiliary circuit:

<b>Product expansion Auxiliary switch</b>		Yes
---	--	-----

#### Protective and monitoring functions:

<b>Trip class</b>		CLASS 10
<b>Design of the overload circuit breaker</b>		thermal (bimetallic)

#### UL/CSA ratings:

<b>Full-load current (FLA) for three-phase AC motor</b>		
• at 480 V Rated value	A	2
<b>yielded mechanical performance [hp]</b>		
• for three-phase AC motor at 460/480 V Rated value	metric hp	0.75
• for three-phase AC motor at 575/600 V Rated value	metric hp	1

#### Short-circuit:

<b>Product function Short circuit protection</b>		Yes
<b>Design of the short-circuit trip</b>		magnetic
<b>Conditional short-circuit current (I<sub>q</sub>)</b>		
• at 400 V acc. to IEC 60947-4-1 Rated value	A	153 000

#### Installation/ mounting/ dimensions:

<b>mounting position</b>		vertical
<b>Mounting type</b>		screw and snap-on mounting onto 35 mm standard mounting rail
<b>Height</b>	mm	170
<b>Width</b>	mm	90
<b>Depth</b>	mm	116
<b>Required spacing</b>		
• for grounded parts		
— forwards	mm	0
— Backwards	mm	0
— upwards	mm	20

— at the side	mm	9
— downwards	mm	10
• for live parts		
— forwards	mm	0
— Backwards	mm	0
— upwards	mm	20
— downwards	mm	10
— at the side	mm	9

#### Connections/ Terminals:

##### Type of electrical connection

- for main current circuit
- screw-type terminals

#### Safety related data:

**B10 value with high demand rate acc. to SN 31920** 1 000 000

##### Proportion of dangerous failures

- with high demand rate acc. to SN 31920

% 73

##### Protection against electrical shock

finger-safe

#### Mechanical data:

**Size of the circuit-breaker** S00

**Size of load feeder** S00

#### Ambient conditions:

##### Ambient temperature

- during operation °C -20 ... +60
- during storage °C -50 ... +80
- during transport °C -50 ... +80

#### Certificates/ approvals:

General Product Approval	For use in hazardous locations	Declaration of Conformity	other
--------------------------	--------------------------------	---------------------------	-------



[Environmental Confirmations](#)

[other](#)

#### Further information

##### Information- and Downloadcenter (Catalogs, Brochures,...)

<http://www.siemens.com/industrial-controls/catalogs>

##### Industry Mall (Online ordering system)

<http://www.siemens.com/industrymall>

##### Cax online generator

<http://support.automation.siemens.com/WW/CAXorder/default.aspx?lang=en&mlfb=3RA22151BA165BB4>

##### Service&Support (Manuals, Certificates, Characteristics, FAQs,...)

<http://support.automation.siemens.com/WW/view/en/3RA22151BA165BB4/all>

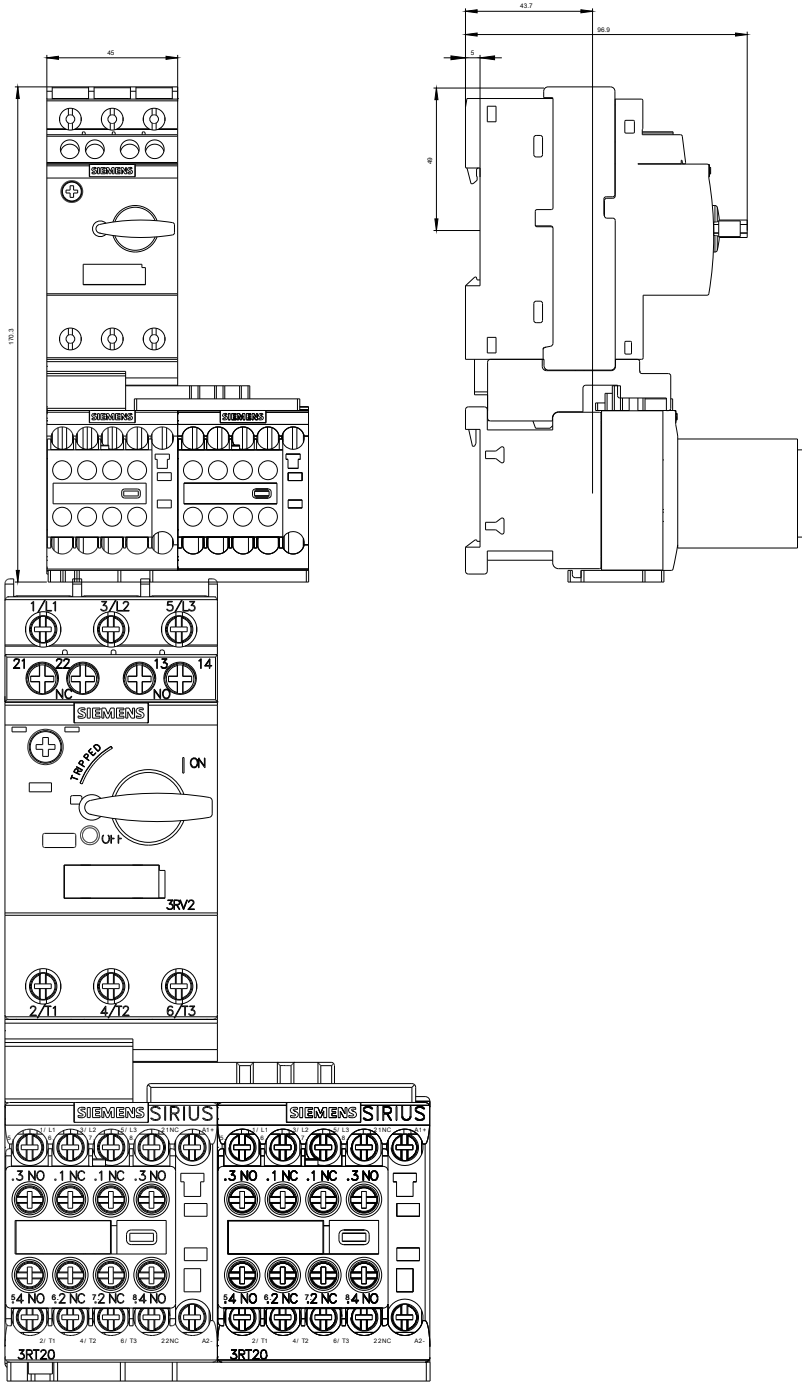

WEINBAUER/ABB/IEC-ÜBERUNGSL

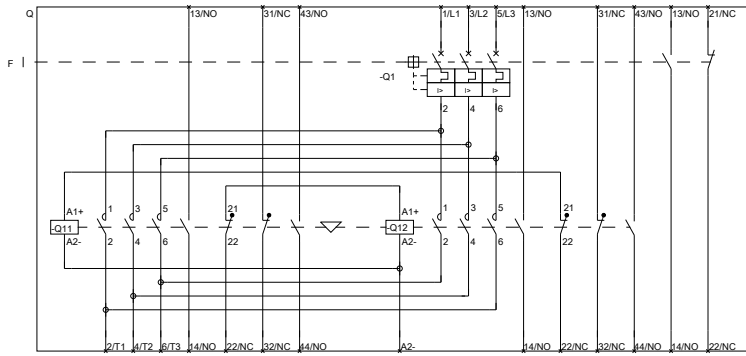

BEWAHRUNGSPROJEKT

last modified:

11.03.2015