

Aluminium double bridge

eepos

Application:

A double-girder crane is used where loads need to be distributed more evenly across multiple chassis and offers extended possibilities for attaching lifting devices.

Execution:

- One set includes: 1 aluminium double girder crane with 4 profile closures, 4 hinge trolleys for connecting to the crane runway and 1 gap trolley for lifting equipment.

Advantage:

- Ergonomic, effortless work
- Low noise emissions
- Smooth running
- Intelligent modular system with a wide range of accessories
- Ensures that the highest level of quality and profitability is retained

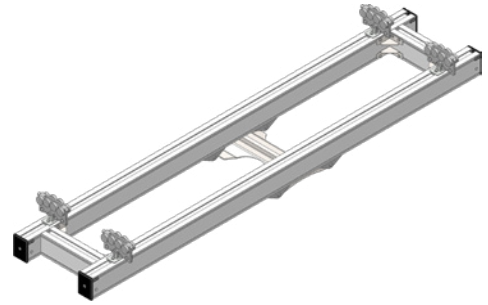

Art. no.	77222 209
Brand	EEPOS
Manufacturer Part Number	S1802233
Load-carrying capacity	1000 kg
Length	3000 mm
Weight	87 kg
Included in delivery	1 set includes: 1 aluminium double girder crane with 4 profile end covers, 4 hinge trolleys to connect to the crane runway and 1 fork trolley 600 kg for lifting equipment
Gross Weight	87.000 kg
Product Group	786