

TOLERANCE UNLESS OTHERWISE SPECIFIED	
.X	±0.15
.XX	±0.10

THIS IS A C.A.D. GENERATED DRAWING
DO NOT MAKE MANUAL REVISIONS TO MASTER.



ISSUE NUMBER

ORIGINAL

1

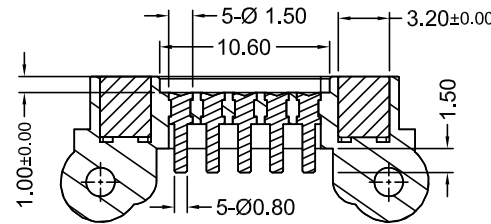
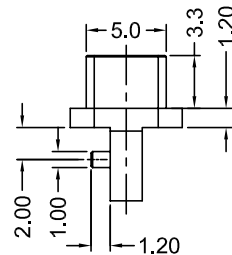
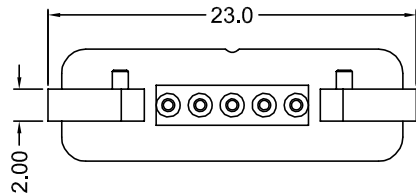
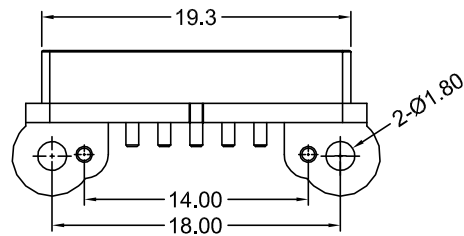
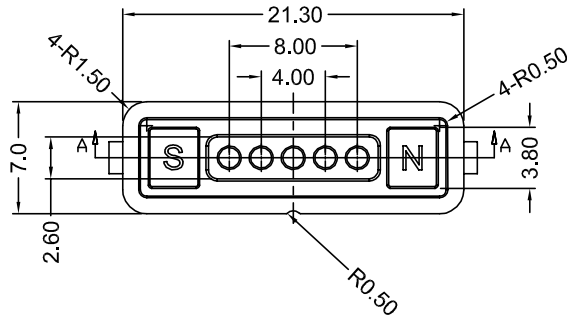

SECTION A-A

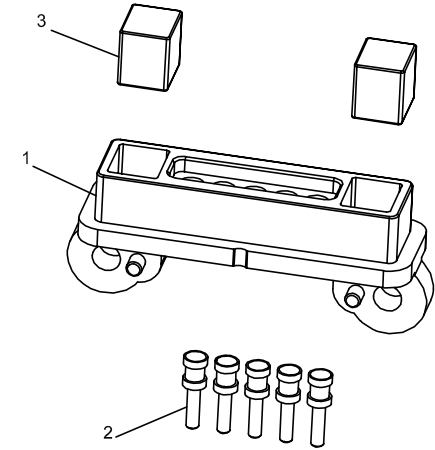

3D VIEW

SPECIFICATION:

VOLTAGE RATING: 5 V
 CURRENT RATING: 2A
 INSULATION RESISTANCE: 100MEGAOHM MIN
 DIELECTRIC WITHSTANDING VOLTAGE: 100V AT 60HZ
 CONTACT RESISTANCE: 30 mOHMS MAX. BEFORE TEST AND
 60mOHMS MAX. AFTER TEST
 SALT SPRAY TEST: 5% SALT SPRAY CONCENTRATION, TEMPERATURE 35°C,
 TEST TIME 48 HOURS, NO CORROSION
 OPERATING TEMPERATURE: -30°C~85°C



THIS SERIES FULLY CONFORMS TO
THE EUROPEAN UNION DIRECTIVES
2011/65/EU FOR RoHS COMPLIANCY.



YOUR CONNECTION TO QUALITY & SERVICE

EDAC INC
TORONTO, ONTARIO
CANADA

THESE DRAWINGS AND SPECIFICATIONS
ARE THE PROPERTY OF EDAC INC., AND
SHALL NOT BE REPRODUCED, OR COPIED
OR USED AS THE BASIS FOR THE
MANUFACTURE OR SALE OF APPARATUS
WITHOUT WRITTEN PERMISSION.

POGO CONNECTOR, 5 POS, FEMALE

ACAD REFERENCE NO.: 686-0052221-111	
DRAWN: E.S	DATE: JUN.6/2022
CHECKED: J.L.	DATE: AUG.04/2022
SCALE: (IN C.A.D. 1:1)	SHEET 1 OF 1
DRAWING NUMBER: 686-0052221-111	ISSUE
PART NUMBER: 686-0052221-111	1