

JN2200

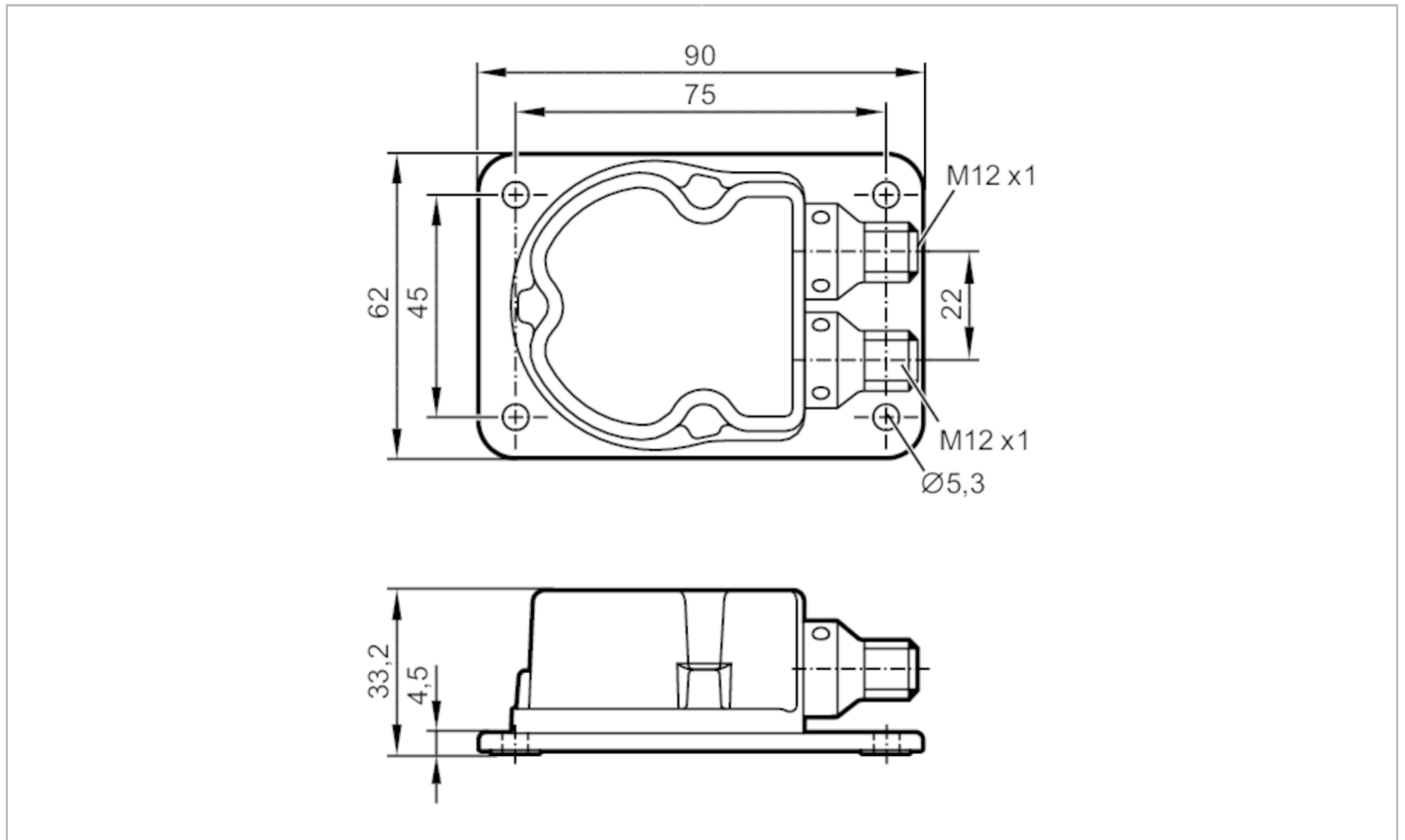

Inclination sensor

INC-M2M360ABIAG/US



Product characteristics	
Dimensions [mm]	90 x 62 x 33.2
Inclination measurement	
Number of measurement axes	2
Angular range [°]	± 180
Application	
Application	High-precision inclination measurement in 2 axes for mobile and industrial applications
Electrical data	
Operating voltage [V]	9.2...30 DC; (voltage output: 12...30 DC; IO-Link: 18...30 DC)
Current consumption [mA]	90; (24 V DC, 25 °C)
Max. current consumption [mA]	330; (9,2 V DC, -40 °C)
Protection class	III
Reverse polarity protection	yes
Reverse polarity protection	yes
Max. initialisation time [ms]	1000
Power-on delay time [s]	300; (warm-up time)
Inputs / outputs	
Number of inputs and outputs	Number of digital outputs: 2; Number of analogue outputs: 2



Inclination sensor

INC-M2M360ABIAKG/US

Outputs	
Total number of outputs	4
Electrical design	PNP/NPN
Number of digital outputs	2
Output function	normally open / normally closed; (programmable)
Max. voltage drop switching output DC [V]	2.5
Permanent current rating of switching output DC [mA]	125; (125 mA (85° C); 200 mA (60° C); 250 mA (40° C))
Number of analogue outputs	2
Analogue current output [mA]	4...20; (in case of a fault: 2 mA)
Max. load [Ω]	220; (220 (9,2...15 V) / 500 (15...30 V))
Analogue voltage output [V]	2...10; (in case of a fault: 1 V)
Min. load resistance [Ω]	1000; (10000 (12...13,5 V) / 1000 (13,5...30 V))
Precision analogue output [%]	≤ 1
Short-circuit protection	yes
Overload protection	yes
Measuring/setting range	
Measuring principle	MEMS capacitive
Inclination measurement	
Number of measurement axes	2
Number of measurement axes	2
Angular range [°]	± 180
Angular range [°]	± 180
Limit frequency [Hz]	0.5...10; (parameterisable)
Vibration measurement	
Measuring range of vibration	16; (± 2; ± 4; ±8 g parameterisable) g 3200 mm/s
Frequency range [Hz]	0.1...400
Number of measurement axes	X/Y/Z parameterisable
Accuracy / deviations	
Accuracy [°]	≤ ± 0,5
Repeatability [°]	≤ ± 0,1
Resolution [°]	0.05
Temperature coefficient [1/K]	≤ ± 0,02
Software / programming	
Parameter setting options	angle (X/Y) / vibration (Veff / aPeak); hysteresis / window; switch points; switching logic; fault indication; self-test; current/voltage output

JN2200



Inclination sensor

INC-M2M360ABIAGK/US

Interfaces		
Communication interface	IO-Link	
Transmission type	COM2 (38,4 kBaud)	
IO-Link revision	1.1	
SDCI standard	IEC 61131-9 CDV	
IO-Link device ID	416 / 0x0001A0	
Profiles	Smart Sensor: Process Data Variable; Device Identification, Device Diagnosis	
SIO mode	yes	
Required master port type	A	
Process data analogue	2	
Process data binary	2	
Min. process cycle time [ms]	5	
Operating conditions		
Ambient temperature [°C]	-40...85	
Storage temperature [°C]	-40...85	
Protection	IP 65; IP 67; IP 68; IP 69K	
Tests / approvals		
EMC	DIN EN 61000-4-2 ESD	4 kV CD / 8 kV AD
	DIN EN 61000-4-3 HF radiated	10 V/m
	DIN EN 61000-4-4 Burst	2 kV
	DIN EN 61000-4-6 HF conducted	10 V
	DIN EN 55022 class B / CISPR 16-2-3	30 - 1000 MHz
	CISPR 25 ECE R 10	30 - 1000 MHz narrowband and broadband
	ISO 11452-2 ECE R 10	20 - 2000 MHz / 30 V/m
	ISO 7637-2 ECE R 10	pulse 1, 2a, 2b, 3a, 3b, 4, and pulse emission during operation, switching-on, switching-off
Shock resistance	DIN EN 60068-2-27	100 g 1 ms / 10000 impacts per axis (X/Y)
	DIN EN 60068-2-29	30 g 6 ms / 24000 shock (bump)
Vibration resistance	DIN EN 60068-2-64	10...2000 Hz Test VII / random, mounting place car body
	DIN EN 60068-2-6	10...500 Hz / 10 g 10 cycles/axis, sine
Salt spray test	DIN EN 60068-2-52	severity level 5 (motor vehicle)
Damp heat	DIN EN 60068-2-30	55 °C cyclic upper temperature / 95 % rh 2 cycles of 24 h
MTTF [years]	176	
Standard	Compliant with ECE R 10, rev. 5; ISO 7637-3: 2007-07	
Mechanical data		
Weight [g]	410	
Dimensions [mm]	90 x 62 x 33.2	
Materials	housing: diecast zinc nickel-plated	
Displays / operating elements		
Display	operation	1 x LED, green
	switch point	1 x LED, yellow
Accessories		
Accessories (supplied)	Protective cover	

JN2200



Inclination sensor

INC-M2M360ABIAGK/US

Remarks

Pack quantity 1 pcs.

Electrical connection - digital

- | | |
|---|----------------------------------|
| 1 | L+ 24 V DC (+Ub-D) |
| 2 | switching output OUT 2 |
| 3 | L - GND |
| 4 | switching output OUT 1 / IO-Link |

Connector: 1 x M12



Electrical connection - analogue

- | | |
|---|--------------------|
| 1 | L+ 24 V DC (+Ub-A) |
| 2 | analogue output A2 |
| 3 | L - GND |
| 4 | analogue output A1 |

Connector: 1 x M12





Inclination sensor

INC-M2M360ABIAG/US

Other data

Measuring/setting range

inclination measurement			min.	max.
switch point	SP1	[°]	-179.00	180.00
reset point	rP1	[°]	-180.00	179.00
switch point	SP2	[°]	-179.00	180.00
reset point	rP2	[°]	-180.00	179.00
Analogue start point	ASP1	[°]	-180.00	179.00
Analogue end point	AEP1	[°]	-179.00	180.00
Analogue start point	ASP2	[°]	-180.00	179.00
Analogue end point	AEP2	[°]	-179.00	180.00
In steps of		[°]	0.01	
vibration measurement			min.	max.
switch point	SP1	[mm/s]	1	3200
reset point	rP1	[mm/s]	0	3199
Analogue start point	ASP3	[mm/s]	0	3199
Analogue end point	AEP3	[mm/s]	1	3200
In steps of		[mm/s]	1	
vibration measurement			min.	max.
switch point	SP2	[mg]	1	16000
reset point	rP2	[mg]	0	15999
Analogue start point	ASP4	[mg]	0	15999
Analogue end point	AEP4	[mg]	1	16000
In steps of		[mg]	1	