

Amphenol Canada Corp - Product Change Notice (PCN)

PCN Date	Feb.17,2022
Supplier Name:	Amphenol Canada Corp.
Amphenol Canada PCN Number	PCN-C1646
Description of Change	Appearance and contact tail plating and some solder cup direction are different.
Reason for Change	The mould of the original D-sub are aging and out of control lead time for D-sub parts.
Summary of changes between new and old part	All of the contact tail are tin plating. The solder cup version middle row of contacts changed the solder cup opening direction. See the next page for the detail
Traceability guidelines (lot code / date code, markings, ship date...)	Data code - 2215
Last Time Buy Date	N/A
Datasheet attached? & Filename(s)	Refer to page 2 & 3
Qual Test data attached? & Filename(s)	N/A

Customer Part Number	Amphenol Old Part Number	Amphenol New Part Number	PCN Effectivity Date	Samples Availability Date	Last Time Buy Date	Expected Supplier Qual Date
NA	17EHD026PAA000 17EHD026SAA000 17EHD026PAM000	Unchanged	11-Apr-22	01-Apr-22	NA	NA
			Estimated	For new sample		

17EHD026PAA000

Old

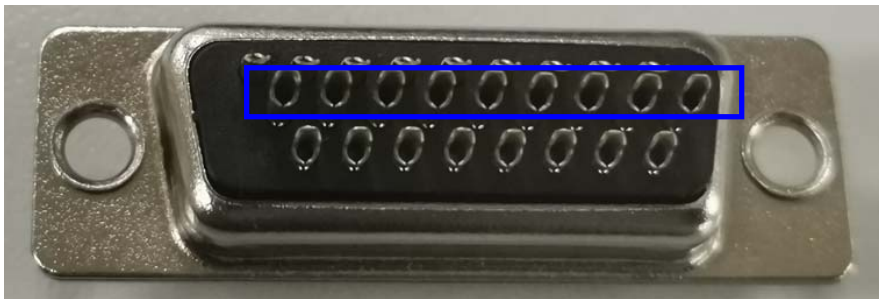

1. The middle row of contact's solder cup is facing down.
2. Contact tails are gold flash plated.

New

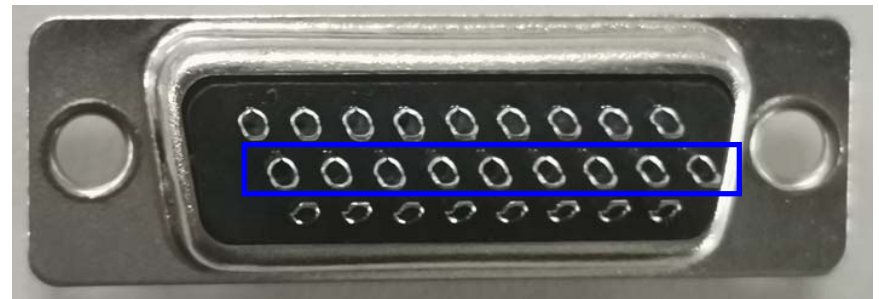

1. The middle row of contact's solder cup is facing up.
2. Contact tails are tin plated.

REVISIONS			
REV	ECN, ERN NO.	DATE	APPRD.
E	PRODUCT DWG PER EAR 14658	MAY07/18	K.L.
F	PRODUCT DWG PER EAR 15082	MAR01/22	A.G.

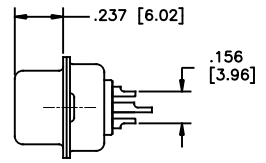
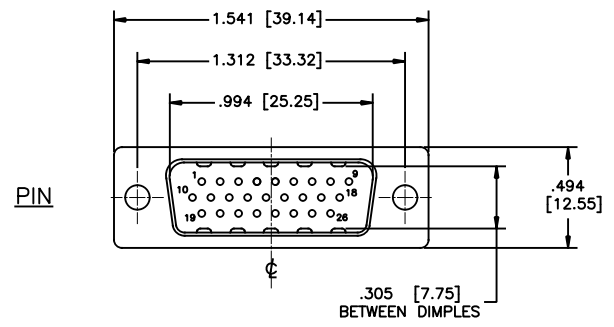

ORDERING CODE:

PART NUMBER: 17EHD-026PAM-100

SERIES _____
NUMBER OF CONTACTS 026
STYLE _____
 P=PIN
 S=SOCKET

TERMINATION-MOUNTING OPTIONS
 000= SOLDER CUP, .120 [3.05] DIA. THROUGH HOLE
 100= SOLDER CUP, #4-40 UNC THREADED HOLES
 200= SOLDER CUP, #4-40 UNC HEX JACK SOCKETS INSTALLED

CONTACT PLATING OPTIONS FOR ENGAGEMENT AREA
 AA= GOLD FLASH
 CH= 15μ" [0.38 MICRONS] GOLD
 AM= 30μ" [0.76 MICRONS] GOLD

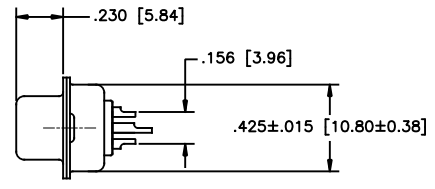
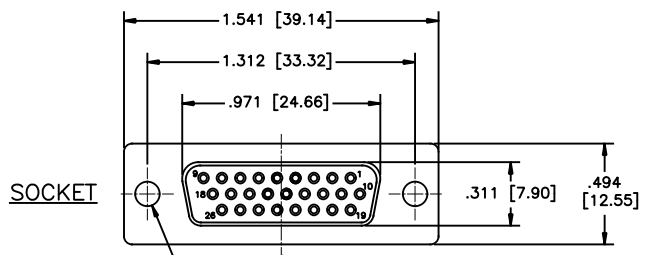

SPECIFICATIONS:

MATERIALS: ALL MATERIALS ARE RoHS COMPLIANT
SHELL: SPCC, NICKEL PLATED ON FRONT SHELL AND TIN ON REAR SHELL.
INSERTS: ENGINEERING THERMOPLASTIC PBT, GLASS REINFORCED, UL FLAMMABILITY RATING 94V-0, COLOUR: BLACK
CONTACTS: COPPER ALLOY, GOLD PLATING (SEE ORDERING CODE) OVER 50u" [1.27 MICRONS] NICKEL ON ENGAGEMENT AREA WITH 80u" [2.03 MICRONS] MIN. TIN ON CONTACT TERMINALS.

TERMINATION-MTG OPTION 000
 SOLDER CUP,
 .120 [3.05] DIA.
 THROUGH HOLE (2 PLACES)

ELECTRICAL DATA:

CURRENT RATING: 3 AMP
CONTACT RESISTANCE: 15 MILLIOHMS MAX.
INSULATION RESISTANCE: 3000 MEGOHMS MIN.
DIELECTRIC WITHSTANDING VOLTAGE: 1000 VAC rms
OPERATING TEMPERATURE: -55°C TO +105°C

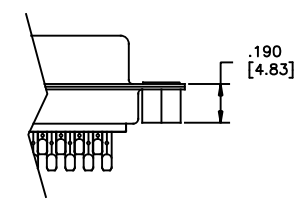
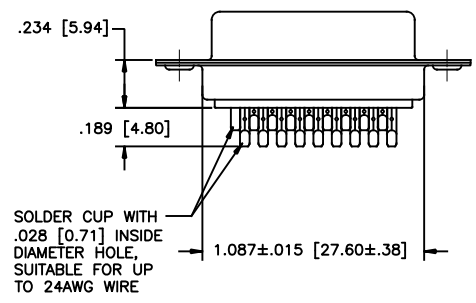

TERMINATION-MTG OPTION 100
 SOLDER CUP,
 #4-40 UNC THREADED THROUGH HOLES

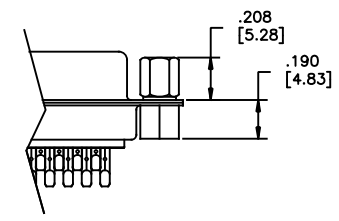

TERMINATION-MTG OPTION 200
 SOLDER CUP,
 #4-40 UNC HEX JACK SOCKETS INSTALLED



DRAWN	J.LEE	DATE	OCT03/06
DESIGNED			
CHECKED	K.LAMBIE	DATE	OCT03/06
I. E. APPRD.			
Q. A. APPRD.			
DWG. APPRD.			
ENG. REL. NO.		DWG	DRAWING NO.
REF.	EAR 12956	C	P-17EHD-026XXX-X00
DIMENSIONS ARE IN	INCHES	CODE ID. NO.	03554

Amphenol Canada Corp.
TITLE 17EHD SERIES HIGH DENSITY D-SUB CONNECTOR, 26 SIZE, SOLDER CUP, PLATING & MOUNTING OPTIONS, RoHS COMPLIANT

DWG	DRAWING NO.	REV.
C	P-17EHD-026XXX-X00	F
SCALE	2/1	WT. _____ SURF. _____ SHEET 1 OF 1

THIS DOCUMENT CONTAINS PROPRIETARY INFORMATION AND SUCH INFORMATION MAY NOT BE DISCLOSED TO OTHERS FOR ANY PURPOSE OR USED FOR MANUFACTURING PURPOSES WITHOUT WRITTEN PERMISSION FROM AMPHENOL CANADA CORP.