

≡	0.25	B
≡	0.25	A

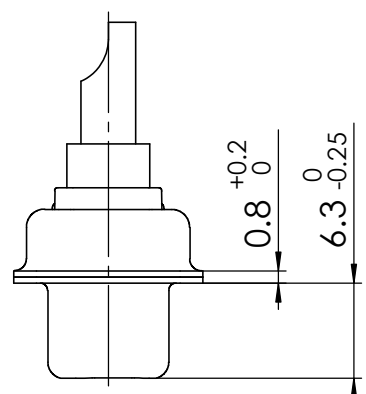

ØF1 = Cable diameter without rubber bushing Ø3 - Ø8.5mm
 ØF2 = Cable diameter with rubber bushing max. 6.5mm

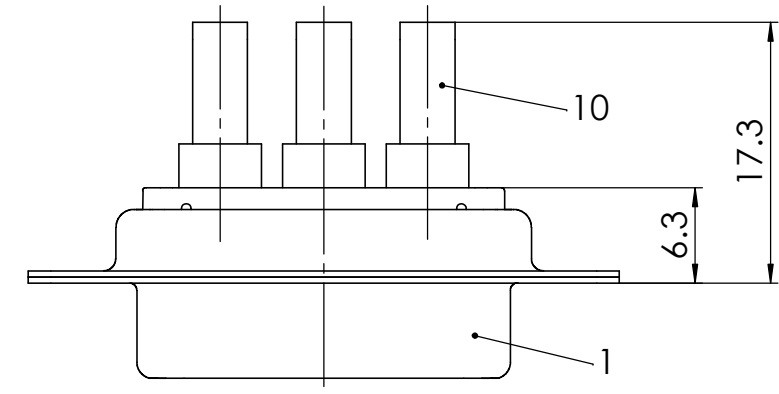
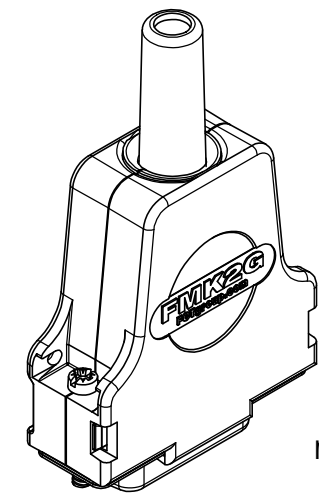
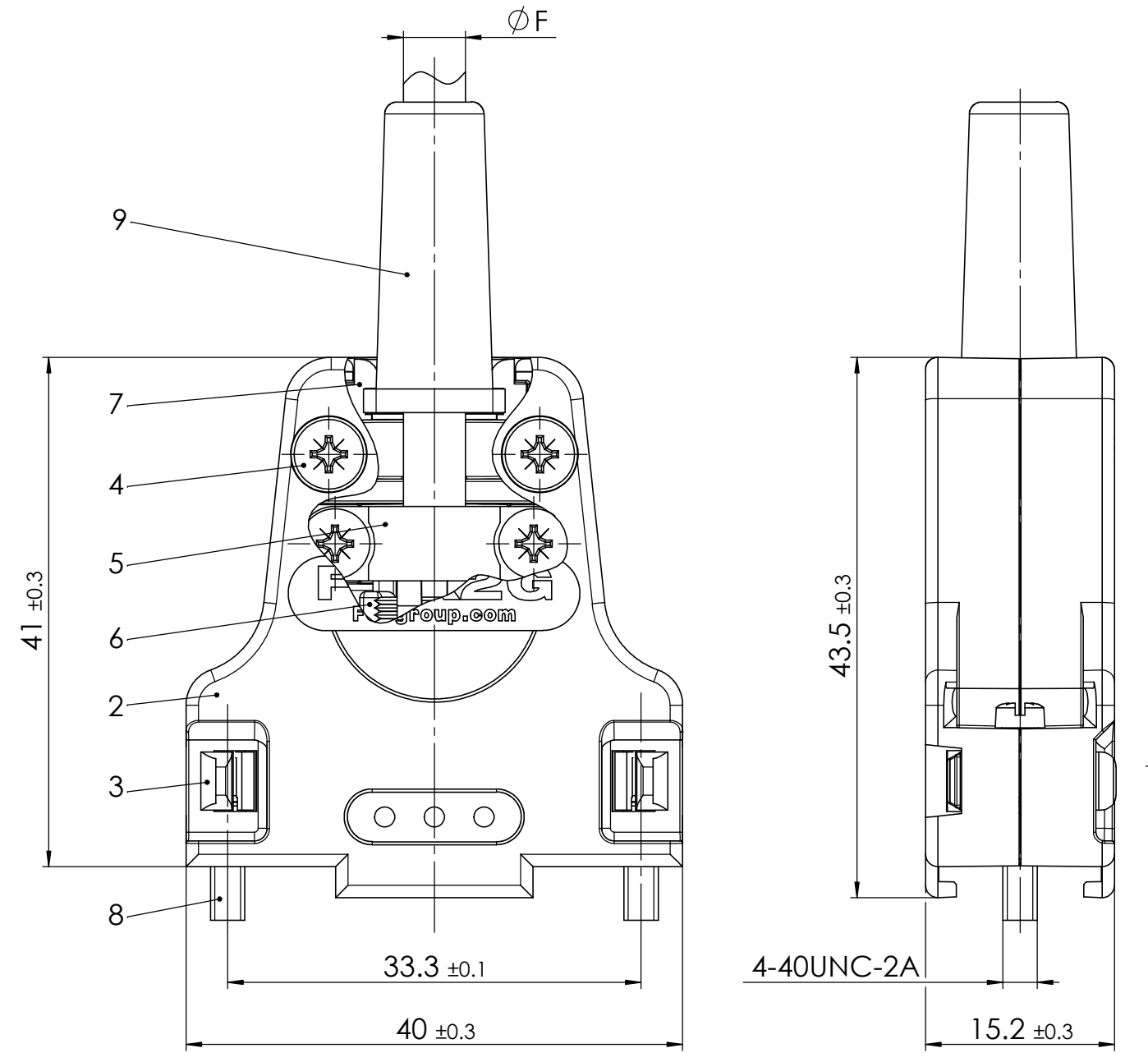

reverse side
1:1

RoHS compliant

max. torque are 40 Ncm
 Part-No. 9 and 10 not mounted

No.	St.	Part	Type	Description / Material	Surface plating / Colour / Class
10	3	High power contact	FMP006S204		AuroPur / 20A / AWG 12-16
9	1	Rubber bushing	TPE		black
8	2	Locking screw	FVS1/5-K1163 4-40 / Steel		nickel plated
7	2	Cable reduction plate	Zinc die-cast		nickel plated
6	1	Strain relief	ABS		nickel plated
5	1	Cable clamp	Steel		tin plated
4	4	Screw	Case hardened steel		zinc plated
3	2	Catch spring	PEI		black
2	1	Hood	FMK2G / Zinc die-cast		nickel plated
1	1	Mixed-Layout Connector	FM3W3S-K121		

		Measurement without tolerance occ. to ISO 2768-m		SCALE	TITLE
				2:1	Hood Connector Set
		DRAWN ameyerrichte 13-10-2016			
		CHECKED BWittef 14-10-2016			
				DWG.NO.	REV.
				FMK2G-3W3SA-5936	1
1					
REV.	DATE	CH.-NO.	ORIGINAL: DIN A3-DRAWING AS A FILE	REPLACEMENT FOR:	PAGES 1

COMMENT: ALL RIGHTS ARE RESERVED BY US FOR THIS DRAWING. WITHOUT OUR PRIOR CONSENT, IT MAY NEITHER BE DUBLICATED NOR MADE AVAILABLE TO A THIRD PARTY. AND IT ALSO MAY NOT BE IMPROPERLY USED BY THE RECEIVER, OR A THIRD PARTY.