

# MOBS. | Horizontal toggle clamps

with straight base and anti-release lever, steel or stainless steel



- 1
- 2
- 3
- 4
- 5
- 6
- 7
- 8
- 9
- 10
- 11
- 12
- 13
- 14
- 15
- 16
- 17
- 18

## STANDARD EXECUTIONS

With open clamping lever and two folded washers:

- **MOBS-NL**: zinc-plated steel body and rivets.
- **MOBS-NLX**: AISI 304 stainless steel body and rivets.

With solid clamping lever and retainer for welding:

- **MOBS-PL**: zinc-plated steel body and rivets.
- **MOBS-PLX**: AISI 304 stainless steel body and rivets.

## SUPPORT BUSHING

Hardened and ground steel (for sizes  $\geq 355$ ).

## HANDLE

Polyurethane, red colour.

## CLAMPING BOLT (TO BE ORDERED SEPARATELY)

## FEATURES AND APPLICATIONS

Anti-release lever to prevent accidental opening in the presence of strong vibrations.

The operator's fingers cannot be hit by the lever while opening.

During clamping, the lever is controlled to prevent impact on functioning due to side thrust.

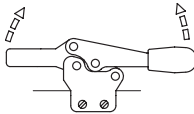

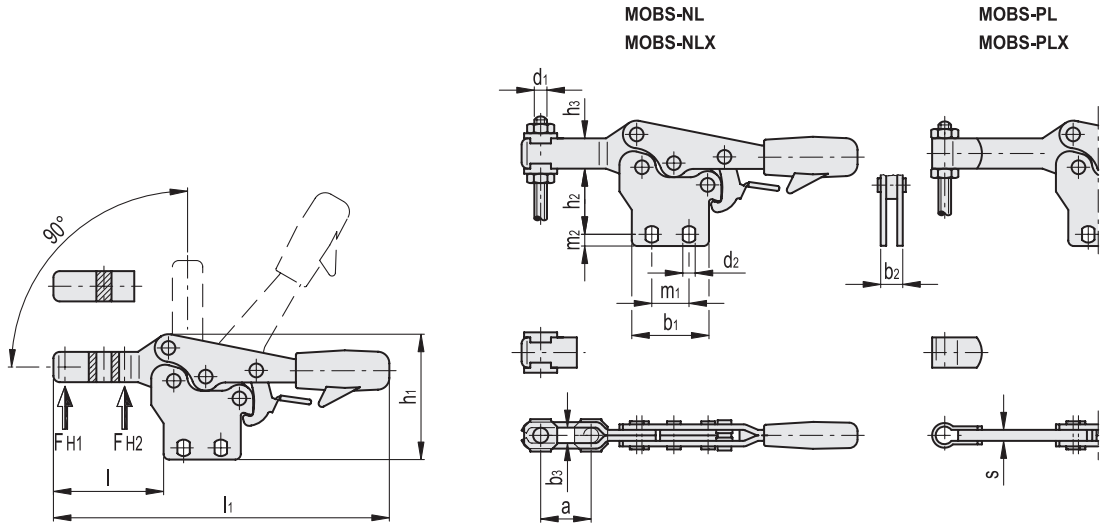

**MOBS-NL**

Code	Description	a	b1	b2	b3	d1	d2	h1	h2	h3	l	l1	m1	m2	FH1 [N]*	FH2 [N]*	⚖️
GG.AD094	MOBS.75-NL	20	28	8	5.3	M5	4.5	45.5	24+25.5	11	39	118	13.5	3.5+5	900	1350	90
GG.AD154	MOBS.130-NL	32	36	10	6.3	M6	5.6	64.5	35+38	16	56.5	171.5	26	5.8+8.8	1000	2000	200
GG.AD292	MOBS.230-NL	37	44	12	8.5	M8	6.6	75.5	42+44.5	18	65	196	26	6.5+9	1700	3300	320
GG.AD392	MOBS.355-NL	58	60	14	10.5	M10	8.6	102	60+62	22	100	269	41	7.5+9.6	1800	4000	730
GG.AD492	MOBS.455-NL	65	70	18	12.5	M12	8.7	120	68+69.5	26	114	305	41.5	11+12.5	3200	6200	1200

**MOBS-NLX**

**INOX** STAINLESS STEEL

Code	Description	a	b1	b2	b3	d1	d2	h1	h2	h3	l	l1	m1	m2	FH1 [N]*	FH2 [N]*	⚖️
GG.DS102	MOBS.75-NLX	20	28	8	5.3	M5	4.5	45.5	24+25.5	11	39	118	13.5	3.5+5	900	1350	90
GG.DS154	MOBS.130-NLX	32	36	10	6.3	M6	5.6	64.5	35+38	16	56.5	171.5	26	5.8+8.8	1000	2000	200
GG.DS289	MOBS.230-NLX	37	44	12	8.5	M8	6.6	75.5	42+44.5	18	65	196	26	6.5+9	1700	3300	320

**MOBS-PL**

Code	Description	b1	b2	d1	d2	h1	h2	h3	l	l1	m1	m2	s	FH1 [N]*	FH2 [N]*	⚖️
GG.AD098	MOBS.75-PL	28	8	M5	4.5	45.5	24+25.5	11	39.5	118.5	13.5	3.5+5	4	900	1350	90
GG.AD158	MOBS.130-PL	36	10	M6	5.6	64.5	35+38	16	57	172	26	5.8+8.8	5	1000	2000	200
GG.AD296	MOBS.230-PL	44	12	M8	6.6	75.5	42+44.5	18	66	196.5	26	6.5+9	6	1700	3300	330
GG.AD396	MOBS.355-PL	60	14	M10	8.6	102	60+62	22	101	270	41	7.5+9.6	7	1800	4000	750
GG.AD496	MOBS.455-PL	70	18	M12	8.7	120	68+69.5	26	115.5	306.5	41.5	11+12.5	10	3200	6200	1220

**MOBS-PLX**

**INOX** STAINLESS STEEL

Code	Description	b1	b2	d1	d2	h1	h2	h3	l	l1	m1	m2	s	FH1 [N]*	FH2 [N]*	⚖️
GG.DS106	MOBS.75-PLX	28	8	M5	4.5	45.5	24+25.5	11	39.5	118.5	13.5	3.5+5	4	900	1350	90
GG.DS158	MOBS.130-PLX	36	10	M6	5.6	64.5	35+38	16	57	172	26	5.8+8.8	5	1000	2000	200
GG.DS293	MOBS.230-PLX	44	12	M8	6.6	75.5	42+44.5	18	66	196.5	26	6.5+9	6	1700	3300	330

\* Holding force.

