

**Features**

- 2-channel isolated barrier
- 24 V DC supply (Power Rail)
- Dry contact or NAMUR inputs
- Isolated passive transistor output, non-polarized
- Line fault detection (LFD)
- Reversible mode of operation
- Up to SIL 2 acc. to IEC 61508

**Function**

This isolated barrier is used for intrinsic safety applications. The device transfers digital signals (NAMUR sensors or dry contacts) from a hazardous area to a safe area. Each input controls a passive transistor output. The outputs are galvanically isolated from each other. Via switches the mode of operation can be reversed and the line fault detection can be switched off. A fault is signaled by LEDs acc. to NAMUR NE44 and a separate collective error message output.

**Assembly**

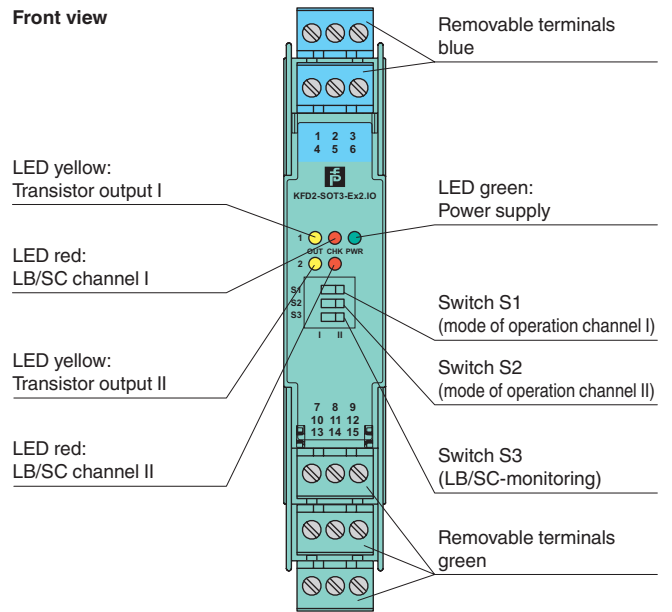

**SIL 2**

**Connection**

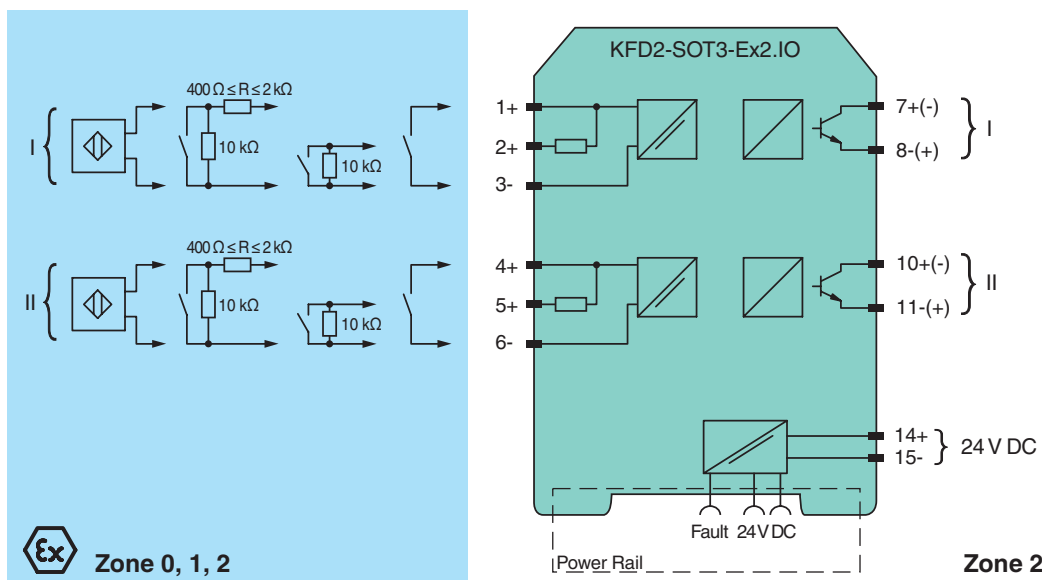

Release date 2017-01-13 13:23 Date of issue 2017-01-13 264212\_eng.xml

Refer to "General Notes Relating to Pepperl+Fuchs Product Information".

<b>General specifications</b>		
Signal type		Digital Input
<b>Supply</b>		
Connection		Power Rail or terminals 14+, 15-
Rated voltage	$U_r$	19 ... 30 V DC
Ripple		≤ 10 %
Rated current	$I_r$	30 ... 20 mA
Power dissipation		≤ 1.1 W including maximum power dissipation in the output
<b>Input</b>		
Connection		terminals 1+, 2+, 3-; 4+, 5+, 6-
Rated values		acc. to EN 60947-5-6 (NAMUR), see system description for electrical data
Open circuit voltage/short-circuit current		approx. 10 V DC / approx. 8 mA
Switching point/switching hysteresis		1.2 ... 2.1 mA / approx. 0.2 mA
Line fault detection		breakage I ≤ 0.1 mA , short-circuit I ≥ 6.5 mA
Pulse/Pause ratio		≥ 100 μs / ≥ 100 μs
<b>Output</b>		
Connection		output I: terminals 7, 8 ; output II: terminals 10, 11
Rated voltage	$U_n$	30 V DC
Rated current	$I_n$	100 mA , short-circuit protected
Response time		≤ 200 μs
Signal level		1-signal: (external voltage) - 3 V max. for 100 mA 0-signal: blocked output (off-state current ≤ 10 μA)
Output I		signal ; Transistor
Output II		signal ; Transistor
Collective error message		Power Rail
<b>Transfer characteristics</b>		
Switching frequency		≤ 5 kHz
<b>Galvanic isolation</b>		
Input/Output		reinforced insulation according to IEC/EN 61010-1, rated insulation voltage 300 V <sub>eff</sub>
Input/power supply		reinforced insulation according to IEC/EN 61010-1, rated insulation voltage 300 V <sub>eff</sub>
Output/power supply		basic insulation according to IEC/EN 61010-1, rated insulation voltage 300 V <sub>eff</sub>
Output/Output		basic insulation according to IEC/EN 61010-1, rated insulation voltage 60 V <sub>eff</sub>
<b>Directive conformity</b>		
Electromagnetic compatibility		
Directive 2014/30/EU		EN 61326-1:2013 (industrial locations)
<b>Conformity</b>		
Electromagnetic compatibility		NE 21:2012 , EN 61326-3-2:2008
Degree of protection		IEC 60529:2001
Input		EN 60947-5-6:2000
<b>Ambient conditions</b>		
Ambient temperature		-20 ... 60 °C (-4 ... 140 °F)
<b>Mechanical specifications</b>		
Degree of protection		IP20
Mass		approx. 150 g
Dimensions		20 x 119 x 115 mm (0.8 x 4.7 x 4.5 inch) , housing type B2
Mounting		on 35 mm DIN mounting rail acc. to EN 60715:2001
<b>Data for application in connection with hazardous areas</b>		
EU-Type Examination Certificate		EXA 16 ATEX 0016 X
Marking		⊕ II 3(1)G Ex nA [ia Ga] IIC T4 Gc ⊕ II (1)D [Ex ia Da] IIIC ⊕ I (M1) [Ex ia Ma] I
Input		Ex ia
Voltage	$U_o$	10.5 V
Current	$I_o$	17.1 mA
Power	$P_o$	45 mW (linear characteristic)
<b>Supply</b>		
Maximum safe voltage	$U_m$	253 V AC (Attention! $U_m$ is no rated voltage.)
<b>Output</b>		
Maximum safe voltage	$U_m$	253 V AC (Attention! The rated voltage can be lower.)
<b>Galvanic isolation</b>		
Input/Output		safe electrical isolation acc. to IEC/EN 60079-11, voltage peak value 375 V
Input/power supply		safe electrical isolation acc. to IEC/EN 60079-11, voltage peak value 375 V
<b>Directive conformity</b>		
Directive 2014/34/EU		EN 60079-0:2012+A11:2013 , EN 60079-11:2012 , EN 60079-15:2010

Release date 2017-01-13 13:23 Date of issue 2017-01-13 264212\_eng.xml

Refer to "General Notes Relating to Pepperl+Fuchs Product Information".

Pepperl+Fuchs Group  
www.pepperl-fuchs.com

USA: +1 330 486 0002  
pa-info@us.pepperl-fuchs.com

Germany: +49 621 776 2222  
pa-info@de.pepperl-fuchs.com

Singapore: +65 6779 9091  
pa-info@sg.pepperl-fuchs.com

<b>International approvals</b>	
IECEX approval	IECEX EXA 16.0009 X
Approved for	Ex nA [ia Ga] IIC T4 Gc , [Ex ia Da] IIIC , [Ex ia Ma] I
<b>General information</b>	
Supplementary information	EC-Type Examination Certificate, Statement of Conformity, Declaration of Conformity, Attestation of Conformity and instructions have to be observed where applicable. For information see <a href="http://www.pepperl-fuchs.com">www.pepperl-fuchs.com</a> .
<b>Accessories</b>	
Optional accessories	power feed module KFD2-EB2 Universal Power Rail UPR-03 Universal Power Rail UPR-03-S profile rail K-DUCT-BU profile rail K-DUCT-UPR-03

Release date 2017-01-13 13:23 Date of issue 2017-01-13 264212\_eng.xml

Refer to "General Notes Relating to Pepperl+Fuchs Product Information".

Pepperl+Fuchs Group  
www.pepperl-fuchs.com

USA: +1 330 486 0002  
pa-info@us.pepperl-fuchs.com

Germany: +49 621 776 2222  
pa-info@de.pepperl-fuchs.com

Singapore: +65 6779 9091  
pa-info@sg.pepperl-fuchs.com

**Configuration**

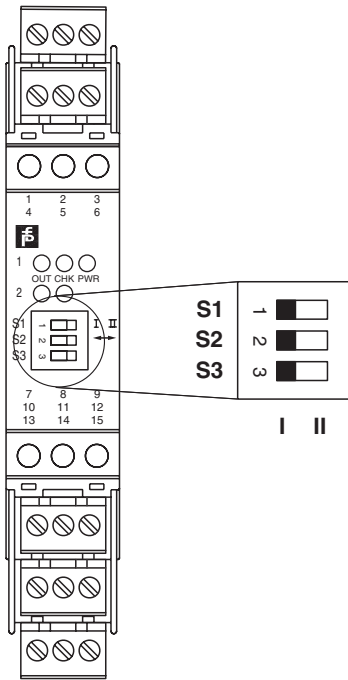

**Switch position**

S	Function		Position
1	Mode of operation Output I active	with high input current	I
		with low input current	II
2	Mode of operation Output II active	with high input current	I
		with low input current	II
3	Line fault detection	ON	I
		OFF	II

**Operating status**

Control circuit	Input signal
Initiator high impedance/ contact opened	low input current
Initiator low impedance/ contact closed	high input current
Lead breakage, lead short-circuit	Line fault

Factory settings: switch 1, 2 and 3 in position I