

## Double-Strand Roller Chains Similar to DIN ISO 606 (formerly DIN 8187), with Straight Plates

**Material:** Special chain steels.

High-quality duplex roller chains, pre-stretched according to DIN.

Notes regarding the performance calculation on page 41.

With straight link plates, to use as conveyor chain or drive chain.

Chains are supplied with an uneven number of links, with inner links at both ends. Connecting links must be ordered separately.

**Temperature range:** -20°C to +120°C.

Other temperatures are possible if special grease is used.

**Ordering Details:** e.g.: Product No. 125 000 00GL, Double-Strand Roller Chain, 08 B-2-GL, with straight plates

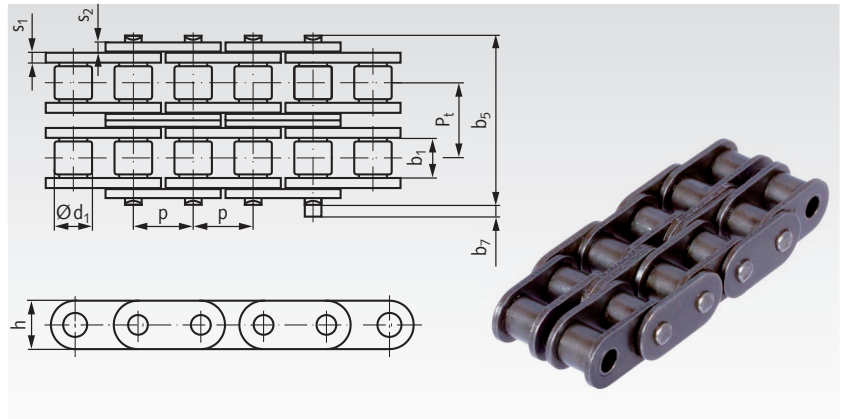

DIN ISO-No.	Product No.	Pitch x Inner Width		Plate Height h max. mm	Plate Thickness s <sub>1</sub> /s <sub>2</sub> max. mm	Roller-Ø d <sub>1</sub> mm	Width over Pin b <sub>5</sub> mm	Transv. Pitch P <sub>t</sub> mm	Projection over link b <sub>7</sub> <sup>1)</sup> mm	Breaking Load min. kN	Weight kg/m	
		mm	inch									
06 B-2	121 000 00*	9,525	x 5,72	3/8 x 7/32	8,26	1,405	6,35	23,8	10,24	3,3	16,9	0,78
08 B-2-GL	125 000 00GL	12,7	x 7,75	1/2 x 5/16	11,8	1,6	8,51	31,2	13,92	3,9	31,1	1,45
10 B-2-GL	126 000 00GL	15,875	x 9,65	5/8 x 3/8	14,7	1,7	10,16	36,1	16,59	4,1	44,5	2,00
12 B-2-GL	127 000 00GL	19,05	x 11,68	3/4 x 7/16	16,0	1,85	12,07	42,0	19,46	4,6	57,8	2,62
16 B-2-GL	128 000 00GL	25,4	x 17,02	1" x 17,02mm	21,0	4,15/3,1	15,88	68,0	31,88	5,4	106,0	6,10
16 B-2-GLH	128 000 00GLH	25,4	x 17,02	1" x 17,02mm	24,0	4,15/3,1	15,88	68,0	31,88	5,4	106,0	6,90
20 B-2-GL	129 000 00GL	31,75	x 19,56	1 1/4 x 3/4	26,4	4,50/3,5	19,05	79,7	36,45	6,1	170,0	8,23

<sup>1)</sup> Maximum values at the link.

\* Standard chain DIN ISO 606.

**Attention please: Packing Unit 5m**  
If special lengths are needed, please tell us the length and the number of links (uneven number!). Connecting links have to be ordered separately.

## Connecting Links for Double-Strand Roller Chains Similar to DIN ISO 606 (formerly DIN 8187), with Straight Plates

**Material:** Special chain steels.



No. 11/E: Connecting Link with Spring Clip



No. 12/L: Cranked Link with Cottered Pin



No. 4/B: Inner Link (2 pieces required)

**Details:** e.g.: Product No. 125 003 00GL, Connecting Link No. 11/E, 08 B-2-GL

DIN ISO No.	Product No. Conn. Link No. 11/E	Weight g	Product No. Cranked Link No. 12/L <sup>1)</sup>	Weight g	Product No. Inner Link No. 4/B <sup>2)</sup>	Weight g
10 B-2-GL	126 003 00GL	31	126 004 00	30	106 001 00GL	18
12 B-2-GL	127 003 00GL	44	127 004 00	47	107 001 00GL	28
16 B-2-GL	128 003 00GL	135	128 004 00	137	108 001 00GL	83
16 B-2-GLH	128 003 00GLH	154	-	-	108 001 00GLH	93
20 B-2-GL <sup>3)</sup>	129 003 00GL	235	129 004 00	343	109 001 00GL	141

<sup>1)</sup> With cranked links, power and breaking loads are reduced by 20%.

<sup>2)</sup> 2 pieces required.

<sup>3)</sup> With cottered pin.