

SECTION A-A
SCALE 2:1

SECTION B-B
SCALE 2:1

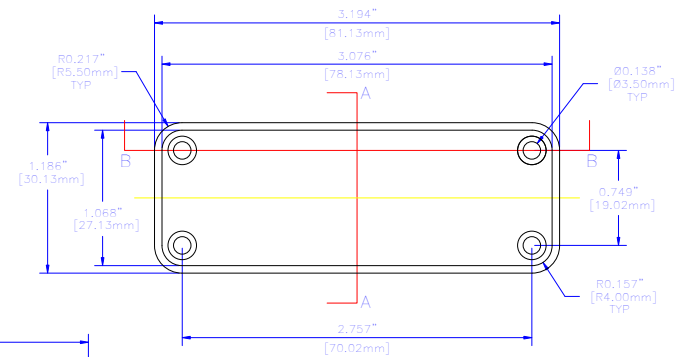

BEZEL

NOTES
 Constructed from extruded Al with a minimum thickness of 0.060"(1.50mm)
 Available in clear or Black anodized finish
 Version 1 includes two Al end panels, and two Black plastic bezels.
 Hardware and self-adhesive rubber feet included.

EXTRUSION

THIS DRAWING IS PROPRIETARY INFORMATION OF HAMMOND MFG.CO.LTD. NOT TO BE USED WITHOUT EXPRESSED WRITTEN PERMISSION OF HAMMOND MFG.CO.LTD.

Rev	EC	Description	Date	By

Unless otherwise specified dimensions are in inches
 Tolerances are:
 .X ± .1
 .XX ± .02
 .XXX ± .010
 .XXXX ± .0005
 Holes ± .0050
 Angles ± .5°

Dwn	T. SPARKS
Date	04 11 02
Chk	---
Mat'l	Extruded Aluminum
Sheet	1 of 2

HAMMOND MANUFACTURING CO. LTD.
 Electronics Group, Waterloo, Ont. - Cheektowaga, NY

HAMMOND 1455 SERIES
 EXTRUDED ALUMINUM

Part #: 1455J1602 Dwg: 1455J1602/A

For the best fit print on legal size paper.

NOTES

Constructed from extruded Al with a minimum thickness of 0.060"(1.50mm)
 Available in clear or Black anodized finish
 Version 1 includes two Al end panels, and two Black plastic bezels.
 Hardware and self-adhesive rubber feet included.

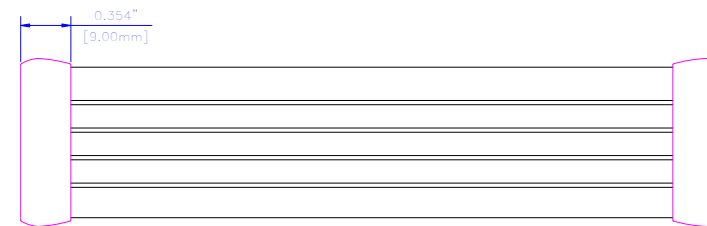
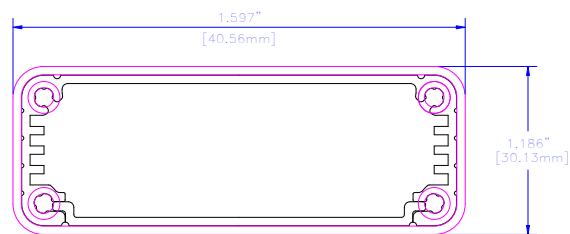
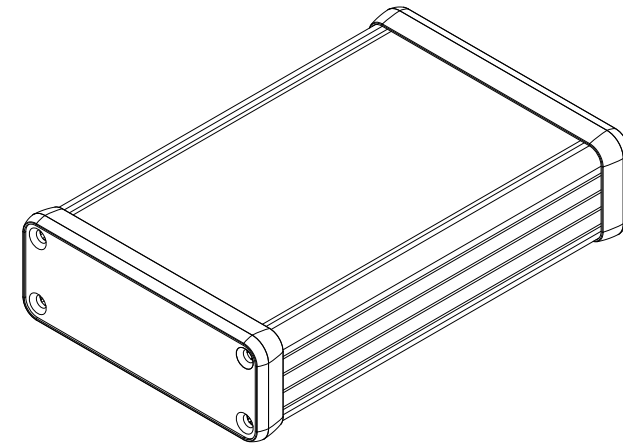
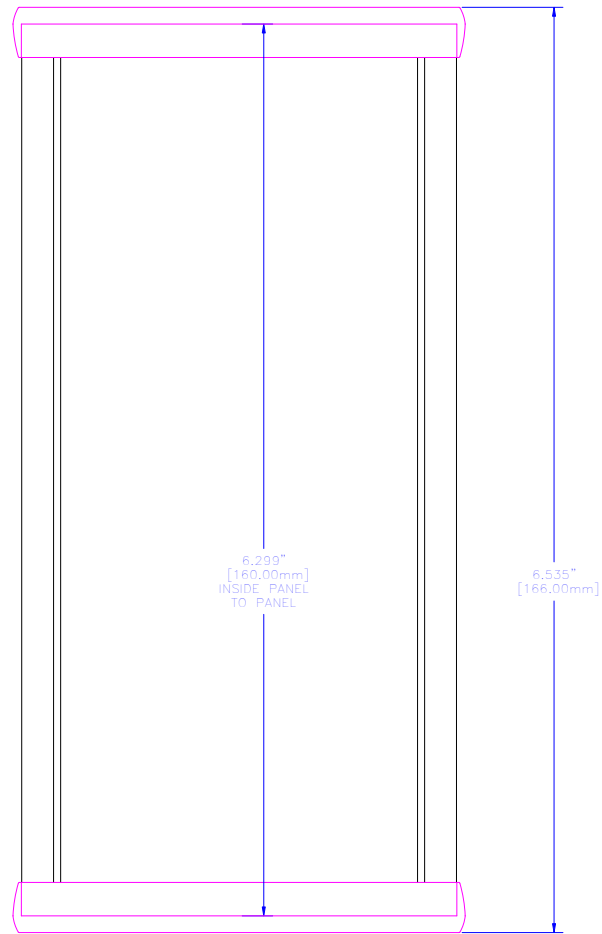

ASSEMBLED

For the best fit print on legal size paper.

THIS DRAWING IS PROPRIETARY INFORMATION OF HAMMOND MFG.CO.LTD. NOT TO BE USED WITHOUT EXPRESSED WRITTEN PERMISSION OF HAMMOND MFG.CO.LTD.

Rev	EC	Description	Date	By

Unless otherwise specified dimensions are in inches
 Tolerances are:
 .X ± .1
 .XX ± .02
 .XXX ± .010
 .XXXX ± .0050
 Holes ± .005
 Angles ± .5°



Own	T. SPARKS
Date	04 11 02
Chk	---
Mat'l	Extruded Aluminum
Sheet	2 of 2

 HAMMOND MANUFACTURING CO. LTD.
 Electronics Group, Waterloo, Ont. - Cheektowaga, NY

HAMMOND 1455 SERIES
 EXTRUDED ALUMINUM

Part #:	1455J1602	Dwg:	1455J1602/A
---------	-----------	------	-------------