

Locking Assemblies TMK

Material Version A: Steel, bright.

Material Version B: Steel with corrosion protection (inner bush and nut nickel-plated, outer bush zinc-plated).

- For fixing a hub (e.g. drive wheel, rotor or similar) on a shaft.
- For medium torques.
- Self-centering.
- With a second hexagon to hold against while tightening the nut.
- Axial offset during mounting (can be compensated by correct positioning).

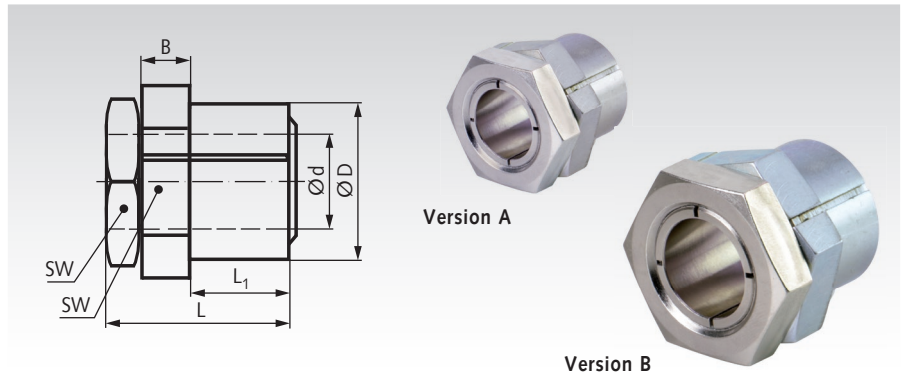

Ordering Details: e.g.: Product No. 615 502 05, Locking Assembly TMK Version A, 5 mm

Product No. Version A	Product No. Version B	d mm	D mm	L mm	L ₁ mm	B* mm	T Nm	F _{ax} kN	P _w N/mm ²	P _N N/mm ²	SW* mm	T _A Nm	Weight g
615 502 05	615 582 05	5	12	19	9	6	10	4,0	264	119	14	10	16
615 502 06	615 582 06	6	12	19	9	6	12	4,0	220	119	14	10	15
615 502 07	615 582 07	7	14	22	11	6	20	5,8	205	121	16	17	23
615 502 08	615 582 08	8	14	22	11	6	23	5,8	180	121	16	17	21
615 502 09	615 582 09	9	18	24	12	7	43	9,7	246	144	22	35	47
615 502 10	615 582 10	10	18	24	12	7	48	9,7	221	144	22	35	44
615 502 11	615 582 11	11	20	24	12	7	59	10,8	225	145	22	44	47
615 502 12	615 582 12	12	20	24	12	7	65	10,8	207	145	22	44	44
615 502 14	615 582 14	14	24	28	15	7	93	13,3	179	118	27	65	76
615 502 15	615 582 15	15	24	28	15	7	99	13,3	167	118	27	65	72
615 502 16	615 582 16	16	24	28	15	7	106	13,3	156	118	27	65	67
615 502 17	615 582 17	17	26	34	16	10	163	19,2	187	148	32	110	122
615 502 18	615 582 18	18	30	36	17	10	223	24,8	224	155	36	160	176
615 502 19	615 582 19	19	30	36	17	10	235	24,8	213	155	36	160	169
615 502 20	615 582 20	20	30	36	17	10	248	24,8	202	155	36	160	162
615 502 22	615 582 22	22	38	41	20	10	349	31,7	197	134	46	250	338
615 502 24	615 582 24	24	38	41	20	10	381	31,7	181	134	46	250	315
615 502 25	615 582 25	25	38	41	20	10	397	31,7	174	134	46	250	304
615 502 28	615 582 28	28	42	44	23	10	565	40,3	174	134	50	355	370
615 502 30	615 582 30	30	42	44	23	10	605	40,3	163	134	50	355	345
615 502 32	615 582 32	32	50	51	28	10	764	47,7	166	112	55	490	552
615 502 35	615 582 35	35	50	51	28	10	836	47,7	152	112	55	490	495
615 502 38	615 582 38	38	58	58	32	11	1140	60,2	155	116	65	700	851
615 502 40	615 582 40	40	58	58	32	11	1200	60,2	147	116	65	700	801
615 502 42	615 582 42	42	60	63	37	11	1250	59,6	120	94	65	740	841
615 502 45	615 582 45	45	60	63	37	11	1340	59,6	112	94	65	740	741

T = transmittable torque at $F_{ax} = 0$.

F_{ax} = transmittable axial force at $T = 0$.

P_w = surface pressure onto the shaft.

P_N = surface pressure onto the hub.

T_A = fastening torque of the screws.

* Slim open-end wrench required.

Fit

Shaft h8, Hub H8.
Surface roughness R_z
max. 12.5 μm .

Construction

The nut is screwed on the inner bush and is hold with it's collar inside the hexagon of the outer bush.

Mounting

It is essential to degrease the shaft and hub. There must be little oil only between the two hexagons. The locking assembly must not get in contact with any fixed components. Hold the back hexagon with a slim open-end wrench and tighten the front hexagon with a torque wrench clockwise to the torque T_A as per the table.

Demounting

Hold the back hexagon with a slim open-end wrench and loosen the front hexagon counter-clockwise, until the inner bush moved a few millimeters out of the outer bush.