



# Push-Pull and E-Stop Switches



# Push-Pull and E-Stop Switches

Honeywell Push-pull and E-stop switches are durable, environmentally sealed, sliding contact switches incorporating two circuits with multiple combinations. The sliding contacts provide positive contact closure and opening when the switch knob is operated.

The dual O-ring design protects the contact chamber by isolating it from any moisture or any other contaminant. These Push-pull and E-stop switches are available as two-circuit switches. Contact closures are available with both circuits closed in the push position, both circuits closed in the pull position, or alternate closure: one closed and one open.

These switches can be a replacement for sealed and unsealed switches including power take-off switches and park brake switches. These rugged and reliable switches increase application reliability and facilitate seamless equipment operation and control with their ability to keep dirt and moisture out of the contact chamber, thereby promoting longer switch life.

Multiple standard knob colors are available with these switches and can be shipped in bulk packaging.

## *What makes our switches better?*

- The dual O-ring design protects the contact chamber by isolating it from any moisture or any other contaminant
- Vibration frequency from 18 Hz to 1000 Hz
- UL and CE certified listings offered
- Self-cleaning, sliding contacts deliver outstanding reliability that enhances performance
- Sliding contacts provide positive contact closure and opening when the switch knob is operated

*Designed for severe temperatures*



HIGH DURABILITY • SLIDING CONTACTS  
MOMENTARY SWITCH OPTION

## Features and Benefits

### **ENVIRONMENTAL PROTECTION**

Honeywell Push-pull and E-stop switches are designed and tested to withstand a wide range of environmental conditions and contaminants: severe temperatures, chemical splashes, pressure wash, vibration, dust, humidity, and salt.

### **IMPROVED DURABILITY**

The dual O-ring design protects the contact chamber by isolating it from moisture and/or any other contaminant.

***Form factor! Easily customized for specific applications***

### **NON-CONDENSING CAPABILITY**

These Push-pull switches can be operated in humidity range of 5 %RH to 95 %RH and are designed for severe temperatures.

### **SLIDING CONTACTS**

The sliding contacts provide positive contact closure and opening when the switch knob is operated.

### **ENHANCED DURABILITY**

IP67 sealing (select listings); resistant to impact, vibration, and shock.

### **MULTIPLE KNOB COLOR AVAILABILITY**

### **UL FILE E219293 (select listings)**

# Push-Pull and E-Stop Switches

## Potential Applications



Honeywell Push-pull and E-stop switches are found in the toughest applications including:

- Construction
- Agricultural
- Marine
- Material handling
- Machine tools
- Mining
- Lawn and garden
- Heavy equipment



# Push-Pull and E-Stop Switches

**Table 1. Electrical, Mechanical, and Environmental Specifications**

Characteristics		Description
<b>Electrical</b>		
Nominal voltage	12 dc, 24 dc, 48 dc, or C300*	
Current, max.	20 A @ 12 Vdc, 10 A @ 24 Vdc, 4 A @ 48 Vdc	
Current, min.	0.1 A, resistive	
Dielectric	500 Vdc or 707 Vdc for 1 minute, 5 mA max.	
Voltage drop	1 Vdc at rated dc loads, max.	
<b>Mechanical</b>		
Operating force	27 N ±14 N	
Life	25,000 cycles at rated load	
Handle shock	1 m [39.37 in] drop to hard surface	
Vibration	10 g max., 18 Hz to 1000 Hz	
Connector	Screw terminals (combo-head), wire harness with 4-pin Deutsch connector	
<b>Environmental</b>		
Humidity	95 % non-condensing	
UV color fade	DE 3 max. at 15,000 hours UVB, ASTM G 154-06	
Temperature	Operating	-40 °C to 40 °C [-40 °F to 104 °F]
	Storage	-40 °C to 80 °C [-40 °F to 176 °F]
Sealing	50058830-05 is IP67 rated	
Approvals	UL, CE (select listings)	

\*For details, please refer Table 2

**Table 2. Electrical Ratings based on Utilization Categories**

Designation <sup>1</sup>	Utilization Category	Conventional Enclosed Thermal Current $I_{the}$ (A)	Rated Operational Current $I_e$ (A) at Rated Operational Voltage						VA Rating	
			120 V	240 V	380 V	480 V	500 V	600 V	Make	Break
	ac	—	120 V	240 V	380 V	480 V	500 V	600 V	Make	Break
C300	AC-15	2,5	1,5	0,75	—	—	—	—	1800	180

Note 1: The letter stands for the conventional enclosed thermal current and identifies (ac or dc); for example B means 5 A ac. The rated insulation voltage  $U_i$  is at least equal to the number after the letter

Note 2: The rated operational current  $I_e$  (A), the rated operational voltage  $U_e$  (V) and the break apparent power B (VA) are correlated by the formula  $B=U_e \cdot I_e$









# Push-Pull and E-Stop Switches

**Table 3. Packaging Options/Codes**

Code	Quantity/Packaging	Fastenings
00	150 units per box	One (1) of each part (mounting nut, large screw, cap, clip, button) and four (4) of each mounting hardware (clamps and short screws) are packed into individual bags. Bags are placed individually with each product in its carton cell.
01	50 units per box	Fifty (50) of each part (mounting nuts, large screws, caps, clips, and buttons) are packed into one large bag and placed into the carton.
02	50 units per box	Fifty (50) of each part (mounting nuts, large screws, caps, clips, buttons, installation screws, and wire clamps) are packed into individual part bags and placed into the carton.
04	100 units per box	100 of each part (mounting nuts, large screws, caps, clips, buttons, installation screws, and wire clamps) are packed in two bags containing 50 of each part and placed into the carton.
05	150 units per box	150 of each part (mounting nuts, large screws, caps, clips, and buttons) are packed into three bags containing 50 of each part and placed in box.
08	48 units per box	One (1) of each part (mounting nut, large screw, cap, clip, button) and four (4) of each mounting hardware (clamps and short screws) are packed into a bag. The bag is placed into an individual box within the carton.
09	150 units per box	One (1) of each part (mounting nut, large screw, cap, clip, button) and four (4) of each mounting hardware (clamps and short screws) are packed into individual bags. 150 bags are then placed into the carton.
12	150 units per box	One (1) of each part (mounting nut, large screw, cap, clip, button) and four (4) of each mounting hardware (clamps and short screws) are packed into individual bags. 150 bags are placed individually with each product in its carton cell.











# Push-Pull and E-Stop Switches

Table 4. Order Guide and Specifications

	Catalog Listing <sup>1</sup>	Knob Color	Circuitry	Terminal Type	Terminals	Approvals	Bulk Packaging	Dimensional Drawing
<b>Push-Pull Switches</b>								
	88843-00	Orange	2NO	Screw terminal	4	UL, CE	150 units per box	Figure 1
	89496-09	Orange	2NC	Screw terminal	4	UL, CE	150 units per box	Figure 2
	90098-09	Orange	1NC/1NO	Screw terminal	4	UL, CE	150 units per box	Figure 4
	50070967-001-00	Orange	2NC	Screw terminal	4	—	150 units per box	Figure 2
	50070967-001-01	Orange	2NC	Screw terminal	4	—	50 units per box	Figure 2
	50070967-001-08	Orange	2NC	Screw terminal	4	—	48 units per box	Figure 2
	50070967-003-00	Yellow	2NC	Screw terminal	4	—	150 units per box	Figure 2
	50070967-003-01	Yellow	2NC	Screw terminal	4	—	50 units per box	Figure 2
	50070967-003-08	Yellow	2NC	Screw terminal	4	—	48 units per box	Figure 2
	50070967-004-00	Black	2NC	Screw terminal	4	—	150 units per box	Figure 2
	50070967-004-01	Black	2NC	Screw terminal	4	—	50 units per box	Figure 2
	50070967-004-08	Black	2NC	Screw terminal	4	—	48 units per box	Figure 2
	50070967-005-08	Green	2NC	Screw terminal	4	—	48 units per box	Figure 2
	50070967-006-08	Blue	2NC	Screw terminal	4	—	48 units per box	Figure 2
	50070967-008-08	Gray	2NC	Screw terminal	4	—	48 units per box	Figure 2
	50070967-009-08	White	2NC	Screw terminal	4	—	48 units per box	Figure 2
	50070974-001-00	Orange	1NC/1NO	Screw terminal	4	—	150 units per box	Figure 4
	50070974-001-01	Orange	1NC/1NO	Screw terminal	4	—	50 units per box	Figure 4
	50070974-001-08	Orange	1NC/1NO	Screw terminal	4	—	48 units per box	Figure 4

<sup>1</sup> Numbers before the dash indicate the model number; the three digit number after the model number indicates the color code and the two digit number following the dash indicates the packaging option. For more information on packaging options, see Table 3.

# Push-Pull and E-Stop Switches

	Catalog Listing <sup>1</sup>	Knob Color	Circuitry	Terminal Type	Terminals	Approvals	Bulk Packaging	Dimensional Drawing
	50070974-003-00	Yellow	1NC/1NO	Screw terminal	4	—	150 units per box	Figure 4
	50070974-003-01	Yellow	1NC/1NO	Screw terminal	4	—	50 units per box	Figure 4
	50070974-003-08	Yellow	1NC/1NO	Screw terminal	4	—	48 units per box	Figure 4
	50070974-004-00	Black	1NC/1NO	Screw terminal	4	—	150 units per box	Figure 4
	50070974-004-01	Black	1NC/1NO	Screw terminal	4	—	50 units per box	Figure 4
	50070974-004-08	Black	1NC/1NO	Screw terminal	4	—	48 units per box	Figure 4
	50070974-005-00	Green	1NC/1NO	Screw terminal	4	—	150 units per box	Figure 4
	50070974-005-01	Green	1NC/1NO	Screw terminal	4	—	50 units per box	Figure 4
	50070974-005-08	Green	1NC/1NO	Screw terminal	4	—	48 units per box	Figure 4
	50070974-006-00	Blue	1NC/1NO	Screw terminal	4	—	150 units per box	Figure 4
	50070974-006-01	Blue	1NC/1NO	Screw terminal	4	—	50 units per box	Figure 4
	50070974-008-00	Gray	1NC/1NO	Screw terminal	4	—	150 units per box	Figure 4
	50070974-008-01	Gray	1NC/1NO	Screw terminal	4	—	50 units per box	Figure 4
	50070974-008-08	Gray	1NC/1NO	Screw terminal	4	—	48 units per box	Figure 4
	50070974-009-00	White	1NC/1NO	Screw terminal	4	—	150 units per box	Figure 4
	50070974-009-01	White	1NC/1NO	Screw terminal	4	—	50 units per box	Figure 4
	50070974-009-08	White	1NC/1NO	Screw terminal	4	—	48 units per box	Figure 4
	50087384-12	Yellow	1NC/1NO	Screw terminal	4	—	150 units per box	Figure 7
<b>E-Stop Switches</b>								
	87941-00	Red	2NC	Screw terminal	4	UL, CE	150 units per box	Figure 2
	87941-01	Red	2NC	Screw terminal	4	UL, CE	50 units per box	Figure 2
	87941-08	Red	2NC	Screw terminal	4	UL, CE	48 units per box	Figure 2
	87943-00	Red	1NC/1NO	Screw terminal	4	UL, CE	150 units per box	Figure 4
	87943-01	Red	1NC/1NO	Screw terminal	4	UL, CE	50 units per box	Figure 4
	87943-08	Red	1NC/1NO	Screw terminal	4	UL, CE	48 units per box	Figure 4
	87944-00	Red	2NO	Screw terminal	4	UL, CE	150 units per box	Figure 1
	87944-04	Red	2NO	Screw terminal	4	UL, CE	100 units per box	Figure 1
	87944-08	Red	2NO	Screw terminal	4	UL, CE	48 units per box	Figure 1

<sup>1</sup> Numbers before the dash indicate the model number; the three digit number after the model number indicates the color code and the two digit number following the dash indicates the packaging option. For more information on packaging options, see Table 3.



# Push-Pull and E-Stop Switches

	Catalog Listing <sup>1</sup>	Knob Color	Circuitry	Terminal Type	Terminals	Approvals	Bulk Packaging	Dimensional Drawing
	50058830-05	Red	1NC/1NO	Wire harness with 4-pin Deutsch connector	n/a	UL, CE	150 units per box	Figure 5
	50070967-002-08	Red	2NC	Screw terminal	4	—	48 units per box	Figure 2
	50070974-002-00	Red	1NC/1NO	Screw terminal	4	—	150 units per box	Figure 4
	50070974-002-01	Red	1NC/1NO	Screw terminal	4	—	50 units per box	Figure 4
	50070974-002-08	Red	1NC/1NO	Screw terminal	4	—	48 units per box	Figure 4
	50093979-05	Red	2NC	Wire harness with 4-pin Deutsch connector	n/a	—	150 units per box	Figure 3
<b>Momentary Push-Pull Switches</b>								
	90201-02	Red	1NC	Screw terminal	2	UL, CE	50 units per box	Figure 6
	90221-09	Orange	2NC	Screw terminal	4	UL, CE	150 units per box	Figure 2

<sup>1</sup> Numbers before the dash indicate the model number; the three digit number after the model number indicates the color code and the two digit number following the dash indicates the packaging option. For more information on packaging options, see Table 3.

# Push-Pull and E-Stop Switches

## DIMENSIONAL DRAWINGS

Figure 1. Push-pull/E-stop switches with 2NO circuitry and screw terminal

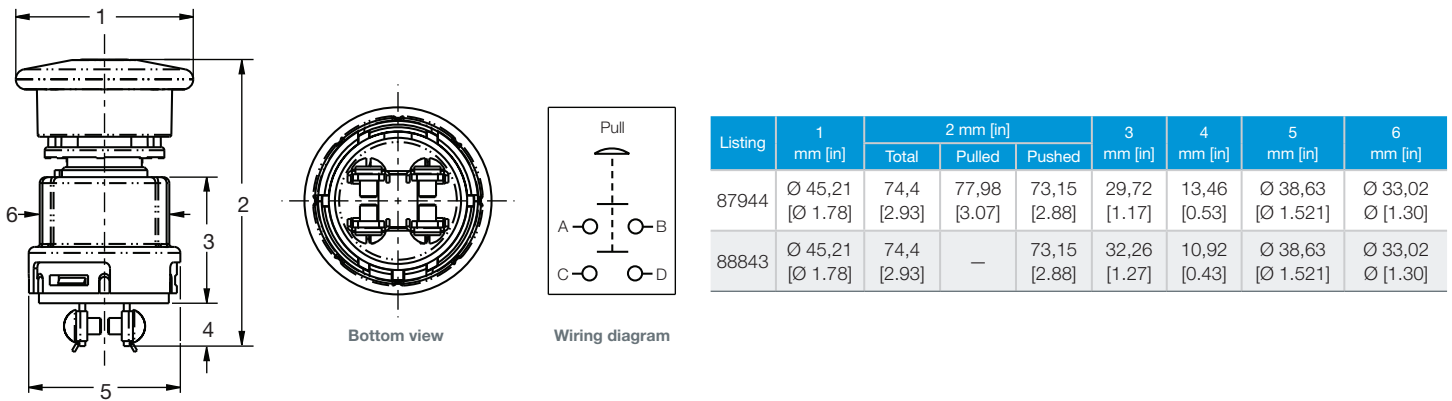

Figure 2. Push-pull/E-stop switches with 2NC circuitry and screw terminal

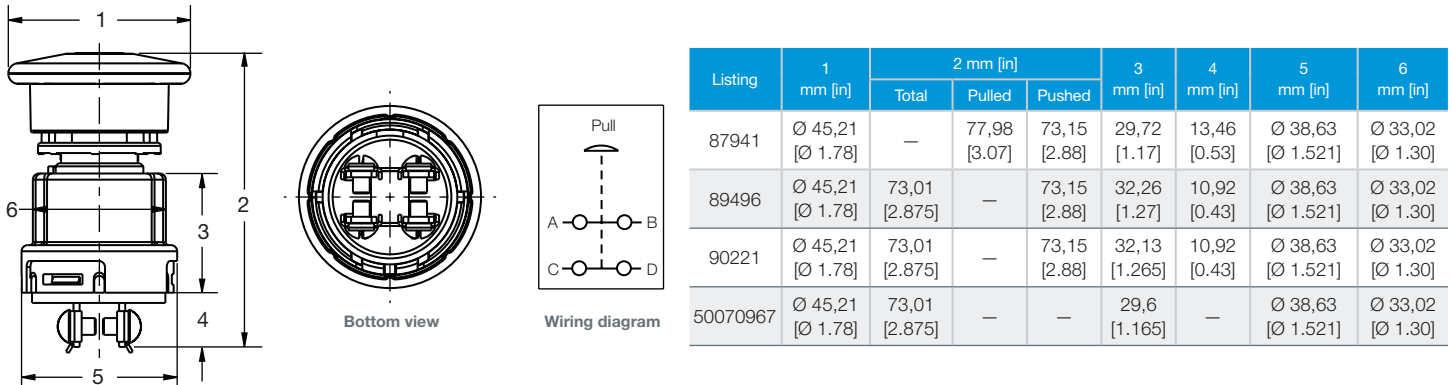
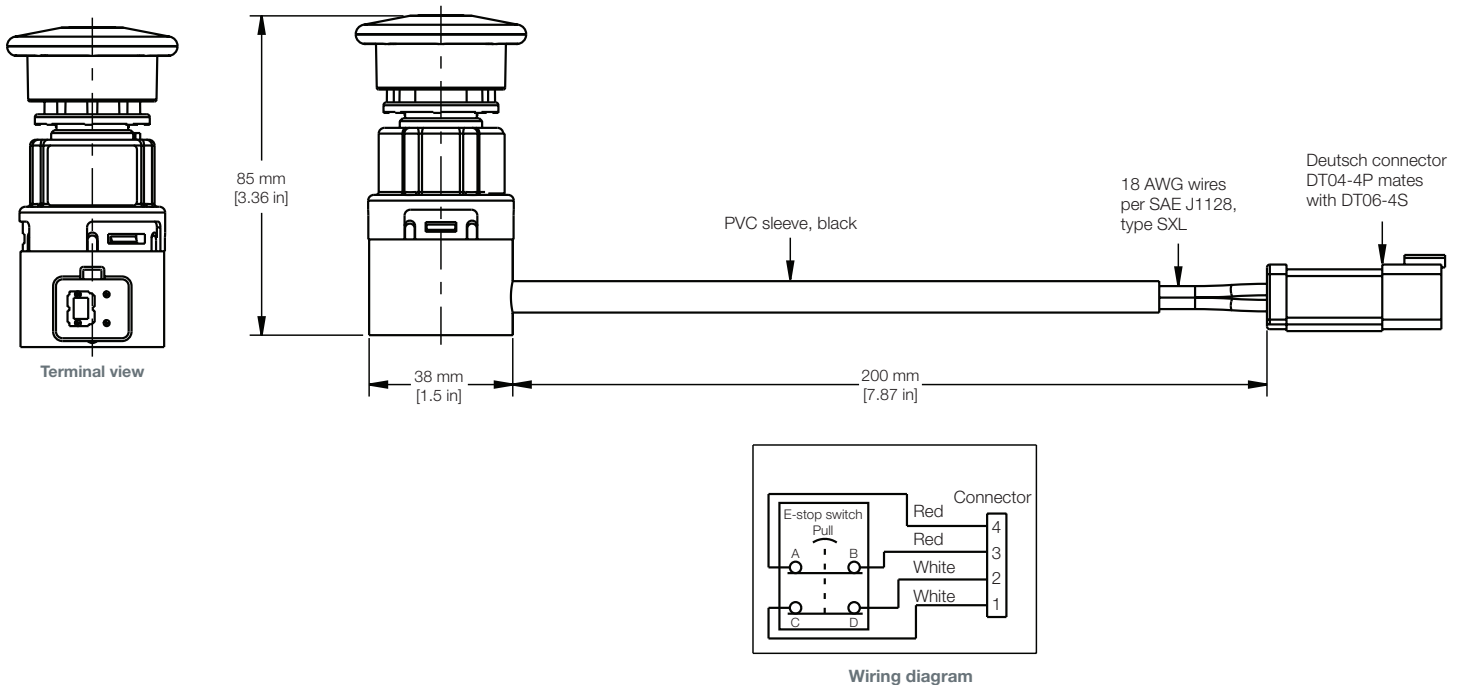

Figure 3. Push-pull/E-stop switches with 2NC circuitry and Deutsch connector, 50093979



# Push-Pull and E-Stop Switches

Figure 4. Push-pull/E-stop switches with 1NC/1NO circuitry and screw terminal

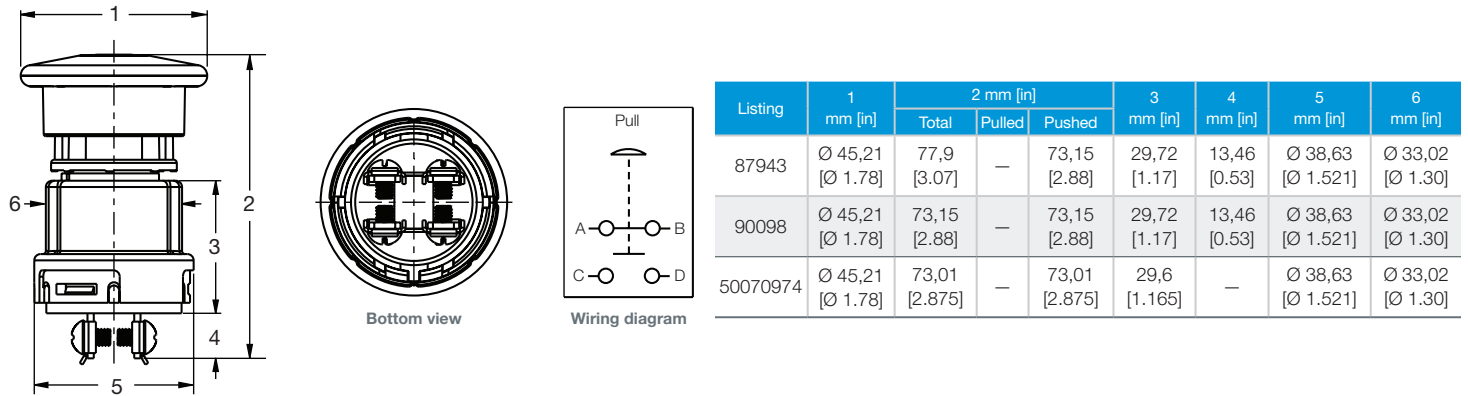

Figure 5. Push-pull/E-stop switches with 1NC/1NO circuitry and Deutsch connector, 50058830

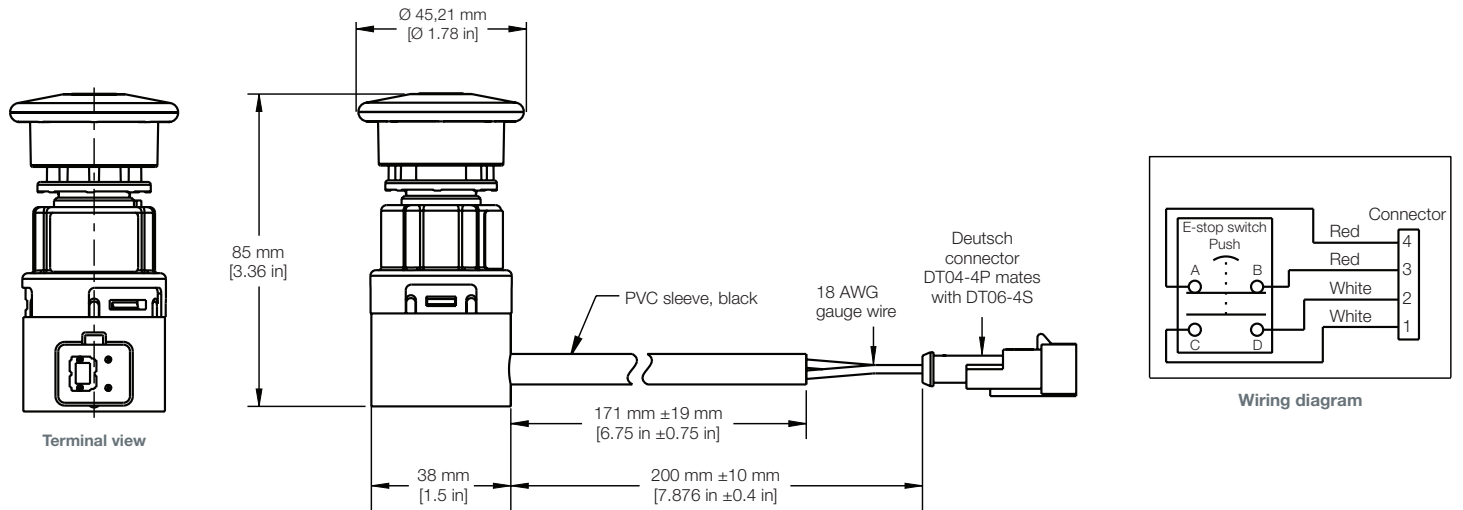
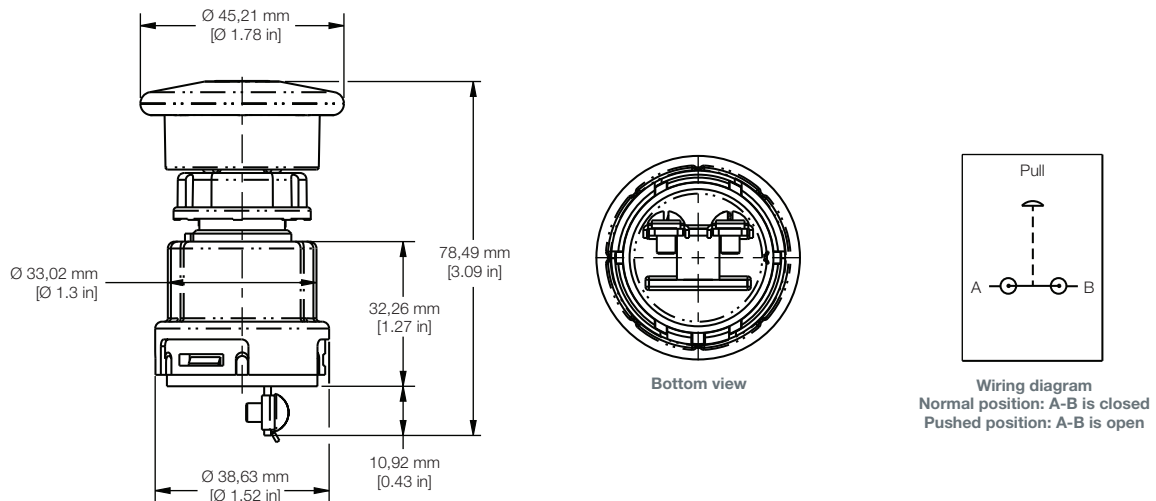
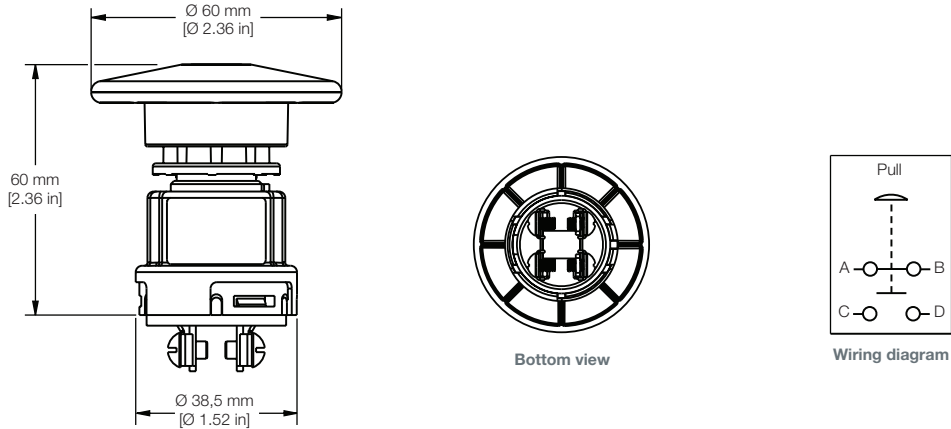

Figure 6. Push-pull/E-stop switches with 1NC circuitry and screw terminal, 90201



# Push-Pull and E-Stop Switches

Figure 7. Push-pull/E-stop switches with 1NC/1NO circuitry and screw terminal, 50087384



## Mounting knobs

Figure 8. 50071755

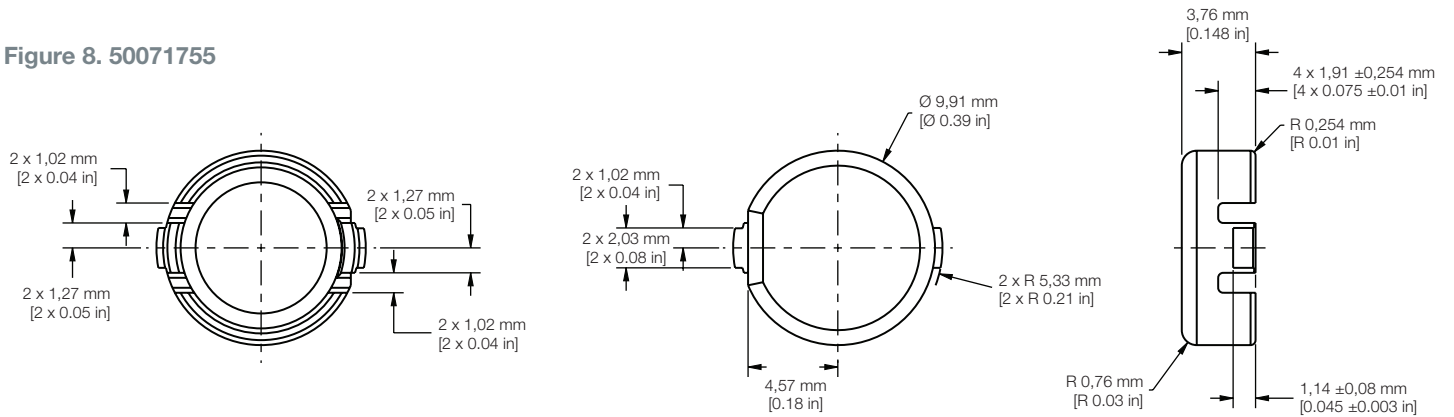
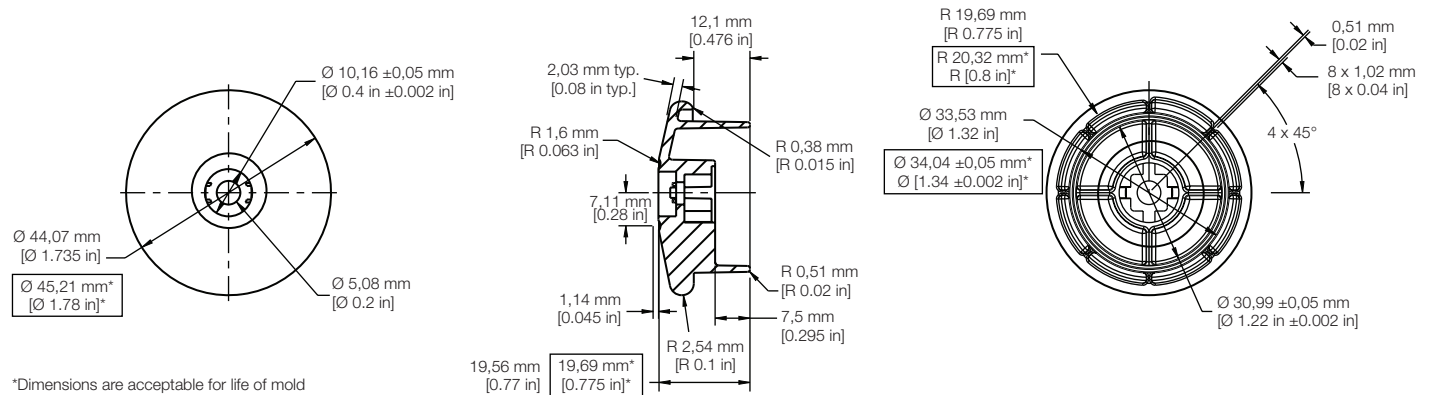
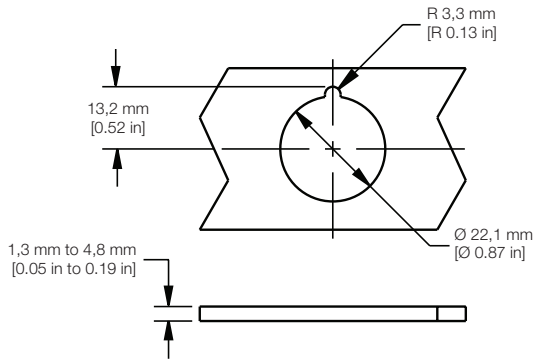

Figure 9. 50071756



# Push-Pull and E-Stop Switches

Figure 10. Recommended mounting hole



Part numbers: 87944, 50058830, 50087384, 50093979

Figure 11. Recommended mounting hole

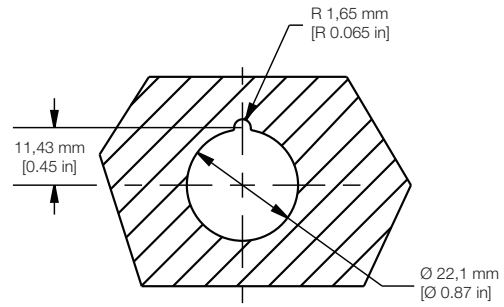

Mounting plate thickness: 1,3 mm to 4,8 mm [0.05 in to 0.19 in]  
Part numbers: 87941, 87943, 88843, 89496, 90201, 90221, 90098, 50070967, and 50070974

Figure 12. Mounting screw 81908

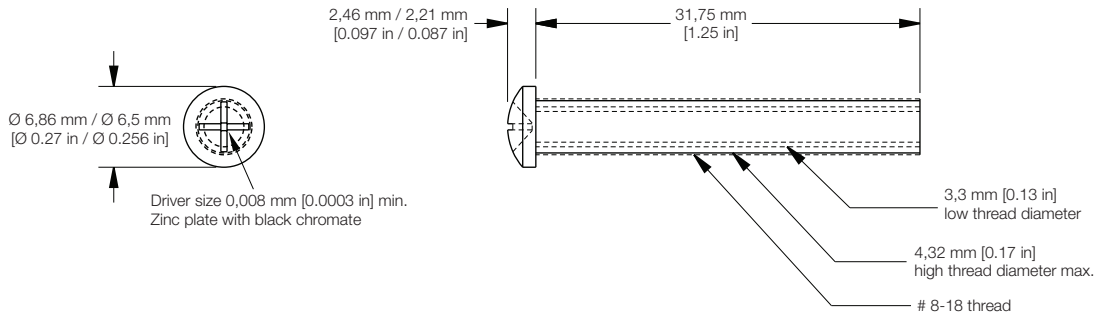

Figure 13. Mounting nut 84508

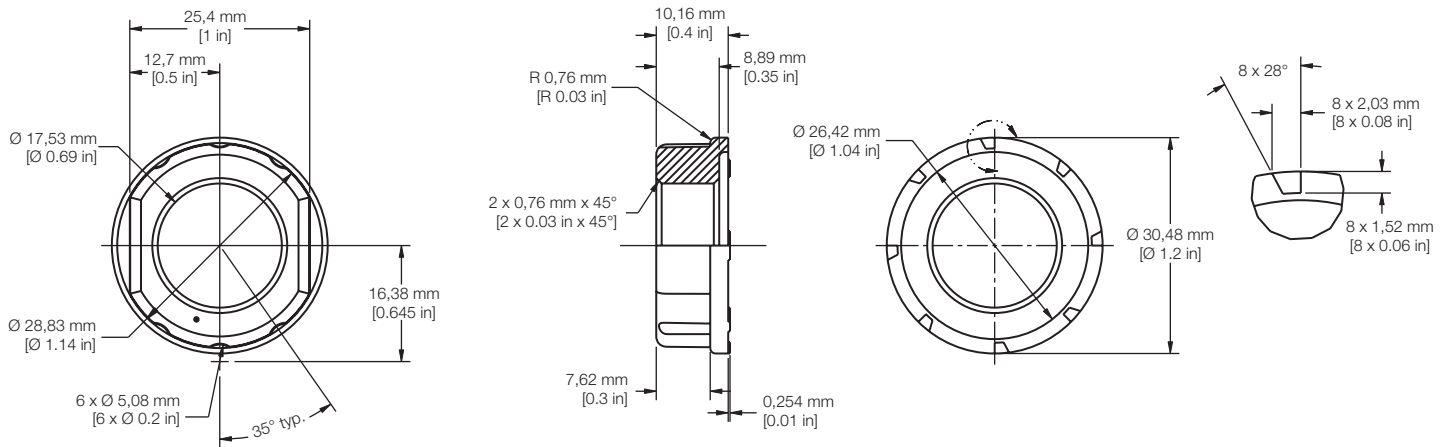
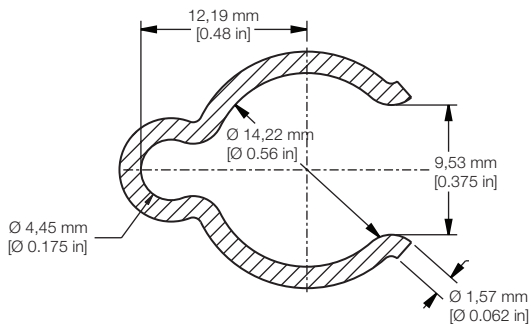

Figure 14. Mounting clip 87770



# Push-Pull and E-Stop Switches

## ADDITIONAL INFORMATION

The following associated literature is available on the Honeywell website at [sensing.honeywell.com](http://sensing.honeywell.com):

- Product line guide
- Product range guide
- Product application-specific information
  - Application note: Sensors and switches in front loaders
  - Application note: Sensors and switches in mobile cranes
  - Application note: Sensors and switches in oil rig applications

### Find out more

Honeywell serves its customers through a worldwide network of sales offices, representatives and distributors. For application assistance, current specifications, pricing or name of the nearest Authorized Distributor, contact your local sales office.

To learn more about Honeywell's sensing and switching products, call **+1-815-235-6847** or **1-800-537-6945**, visit **[sensing.honeywell.com](http://sensing.honeywell.com)**, or email inquiries to **[info.sc@honeywell.com](mailto:info.sc@honeywell.com)**

### Honeywell Sensing and Productivity Solutions

9680 Old Bailes Road  
Fort Mill, SC 29707  
[honeywell.com](http://honeywell.com)

006186-1-EN IL50 GLO  
April 2016  
Copyright 2016 Honeywell International Inc. All rights reserved.

### **WARNING**

#### **PERSONAL INJURY**

**DO NOT USE** these products as safety or emergency stop devices or in any other application where failure of the product could result in personal injury.

**Failure to comply with these instructions could result in death or serious injury.**

### **WARNING**

#### **MISUSE OF DOCUMENTATION**

- The information presented in this product sheet is for reference only. Do not use this document as a product installation guide.
- Complete installation, operation, and maintenance information is provided in the instructions supplied with each product.

**Failure to comply with these instructions could result in death or serious injury.**

## WARRANTY/REMEDY

Honeywell warrants goods of its manufacture as being free of defective materials and faulty workmanship. Honeywell's standard product warranty applies unless agreed to otherwise by Honeywell in writing; please refer to your order acknowledgement or consult your local sales office for specific warranty details. If warranted goods are returned to Honeywell during the period of coverage, Honeywell will repair or replace, at its option, without charge those items it finds defective. **The foregoing is buyer's sole remedy and is in lieu of all other warranties, expressed or implied, including those of merchantability and fitness for a particular purpose. In no event shall Honeywell be liable for consequential, special, or indirect damages.**

While we provide application assistance personally, through our literature and the Honeywell website, it is up to the customer to determine the suitability of the product in the application.

Specifications may change without notice. The information we supply is believed to be accurate and reliable as of this printing. However, we assume no responsibility for its use.

# Honeywell