

B9004808

Unter- und Oberteil EM

Baugruppe: Modernes, flaches Styling. Einfach zu tragen. Vertieft liegende Fläche für Folientastaturen. Fixiersockel für Platinen/Einbauteile im Gehäuseunterteil. Zwischenring EM als separater Artikel erforderlich.

Lieferumfang

1 Ober- und Unterteil EM, 1 selbstformende Schraube



TECHNISCHE DATEN

Material	ABS (UL 94 HB)	Länge	68 mm
Farbe	lava	Breite	42 mm
Standards	RoHS konform, REACH konform	Höhe	18 mm
		Platinenlänge Unterteil	51 mm
		Platinenbreite Unterteil	34 mm
		Folienlänge	44,7 mm
		Folienbreite	27,55 mm

Bitte die Maße an aktuellen Teilen abnehmen. Diese unterliegen material- und produktionsspezifischen Fertigungstoleranzen.

KAUFMÄNNISCHE DATEN

Gewicht/1 Stück	11 g
Warentarifnummer (OKW Produkt)	39269097
Herstellungsland	Deutschland

KUNDENSPEZ. MODIFIKATIONEN

B9004808

Unter- und Oberteil EM

Was benötigen Sie für Ihr persönliches Produkt? Bei Bedarf liefern wir Ihnen die Gehäuse/Drehknöpfe einbaufertig mit allen notwendigen Modifikationen und Veredelungen. Wir beraten Sie gerne. Fragen Sie an!

Produktoptionen für B9004808



Mechanische
Bearbeitung



Bedruckung



Laserbeschriftung



Dekorfolien



Sondermaterial



EMV Schutz



Konfektion / Montage

B9004808

Unter- und Oberteil EM

SYSTEMKOMPONENTEN ZUM KOMPLETTIEREN



B9004702
Zwischenring EM
SEBS (TPE)
lava



B9004703
Zwischenring EM
SEBS (TPE)
orange



B9004704
Zwischenring EM
SEBS (TPE)
grün



B9004705
Zwischenring EM
SEBS (TPE)
blau



B9004707
Zwischenring EM
SEBS (TPE)
grauweiß RAL 9002



B9004708
Zwischenring EM
SEBS (TPE)
vulkan



B9004709
Zwischenring EM
ABS (UL 94 HB)
schwarz RAL 9005



B9004752
Zwischenring EM
SEBS (TPE)
lava



B9004753
Zwischenring EM
SEBS (TPE)
orange



B9004754
Zwischenring EM
SEBS (TPE)
grün



B9004755
Zwischenring EM
SEBS (TPE)
blau



B9004757
Zwischenring EM
SEBS (TPE)
grauweiß RAL 9002



B9004758
Zwischenring EM
SEBS (TPE)
vulkan



B9004759
Zwischenring EM
ABS (UL 94 HB)
schwarz RAL 9005



B9004778
Zwischenring EM, Micro USB 5
P, B Type SMT
SEBS (TPE)
vulkan



B9004782
Zwischenring EM, hoch
SEBS (TPE)
lava

B9004808

Unter- und Oberteil EM



B9004783
Zwischenring EM, hoch
SEBS (TPE)
orange



B9004784
Zwischenring EM, hoch
SEBS (TPE)
grün



B9004785
Zwischenring EM, hoch
SEBS (TPE)
blau



B9004787
Zwischenring EM, hoch
SEBS (TPE)
grauweiß RAL 9002



B9004788
Zwischenring EM, hoch
SEBS (TPE)
vulkan



B9004798
Zwischenring EM, USB Typ A
SEBS (TPE)
vulkan

ZUBEHÖR "TRAGEN"



A9164001
Schlüsselring
Stahl
vernickelt
20,5mm



B9100033
Armband
schwarz
280mm



B9100043
Handschlaufe, Textil
schwarz
200mm



B9100053
Halsband, Textil
schwarz
900x15mm



B9100063
Halsband, Textil
schwarz
860mm

Oberteil ohne Vertiefung
top part without recessed area

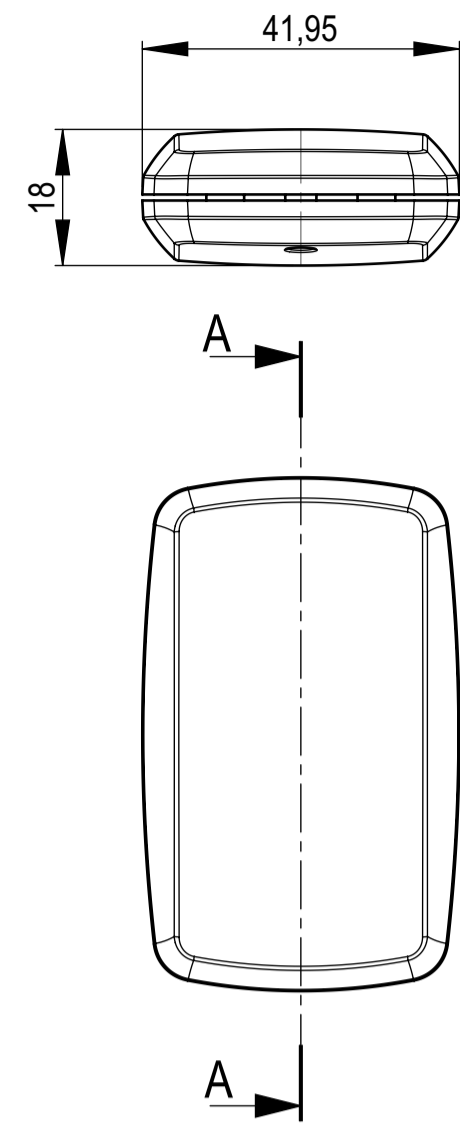

Unter- und Oberteil (nur in Kombination mit Zwischenring)
bottom and top part (only in combination with intermediate ring)

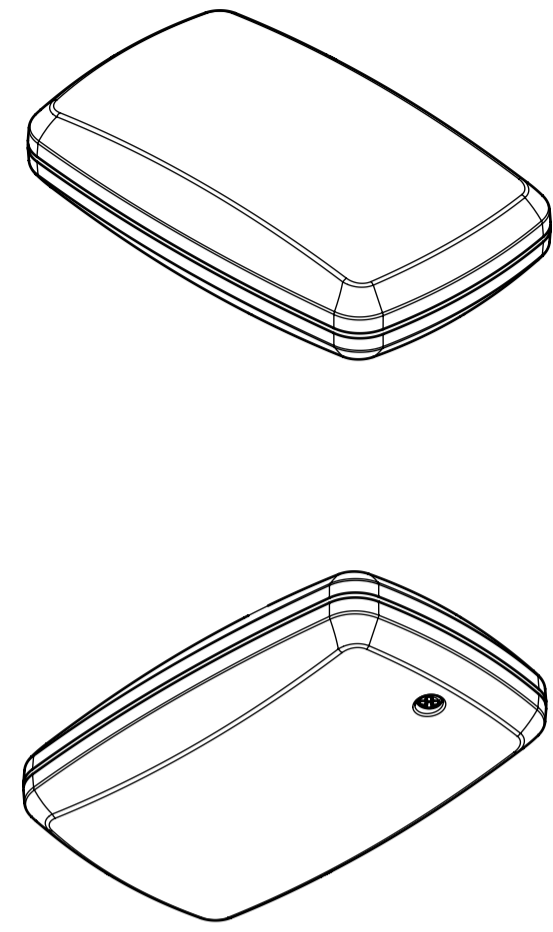
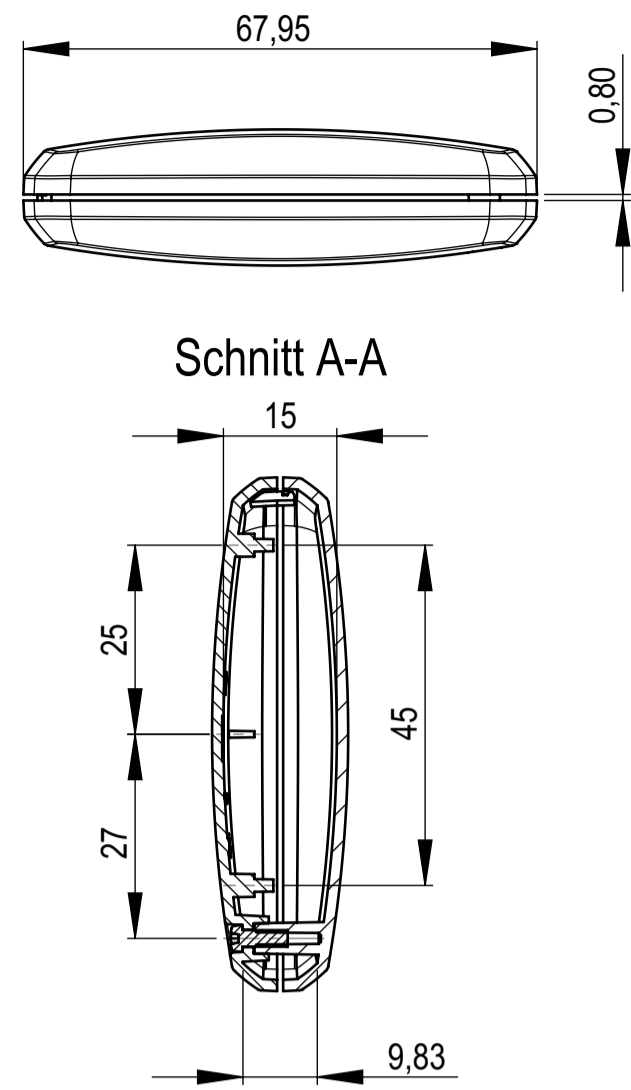

Oberteil mit Vertiefung
top part with recessed area

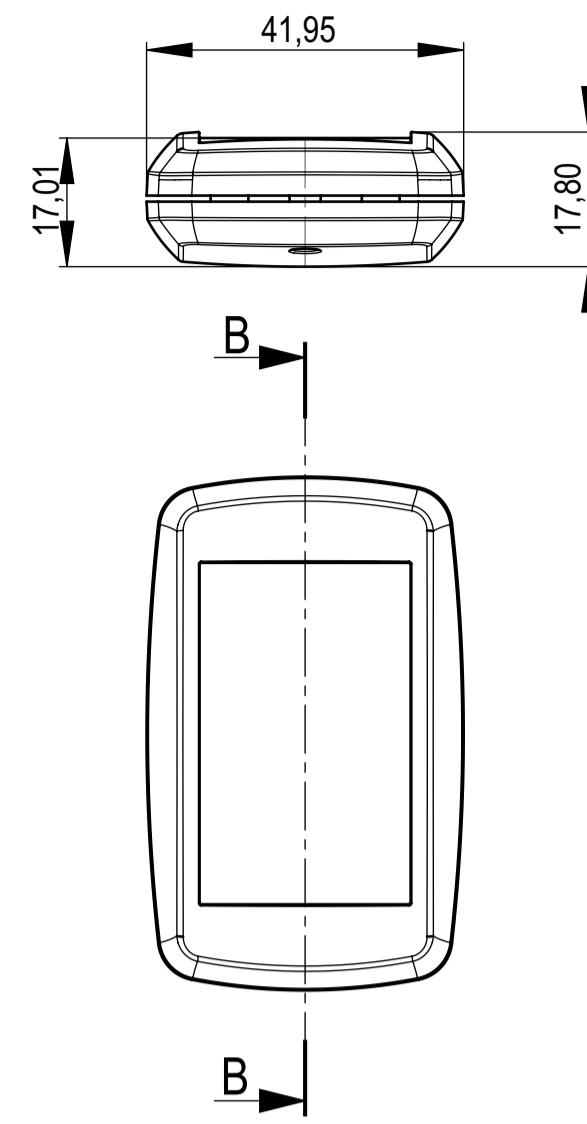

Unter- und Oberteil (nur in Kombination mit Zwischenring)
bottom and top part (only in combination with intermediate ring)

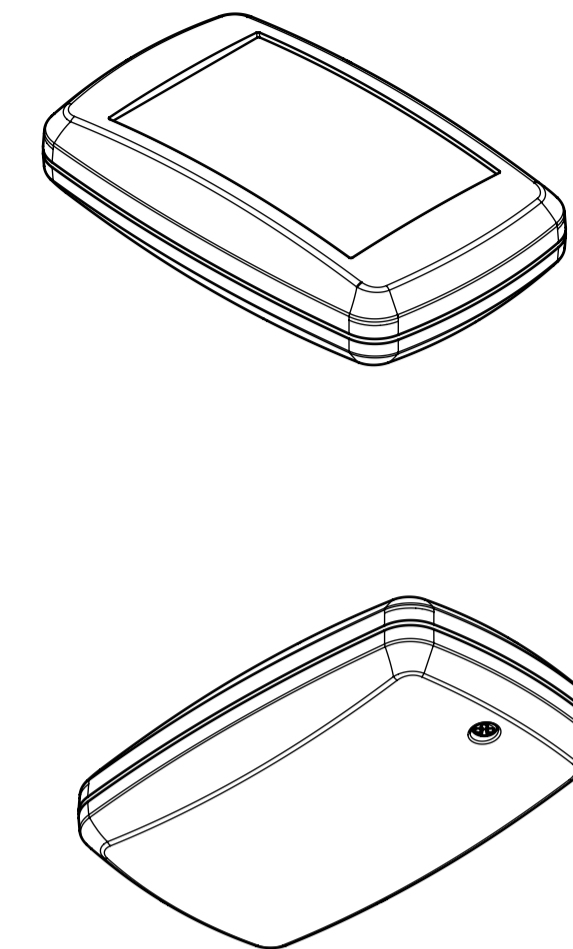
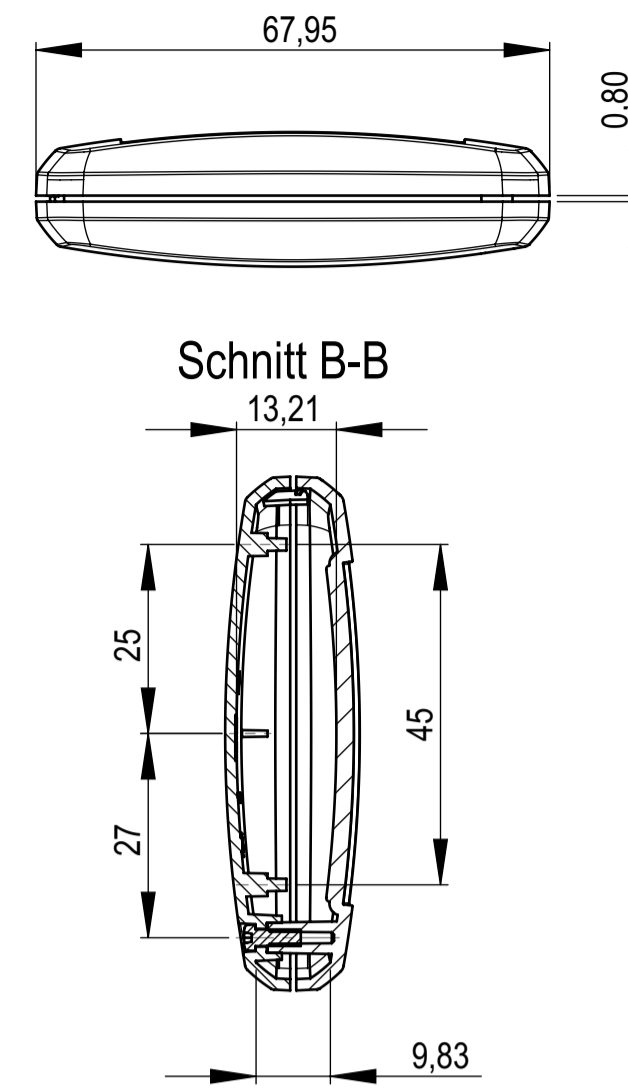

Unterteil
bottom part

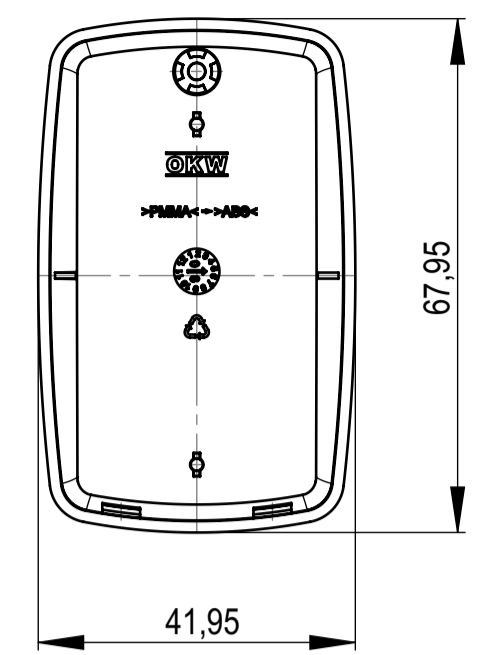

Oberteil ohne / mit Vertiefung
top part without / with recessed area

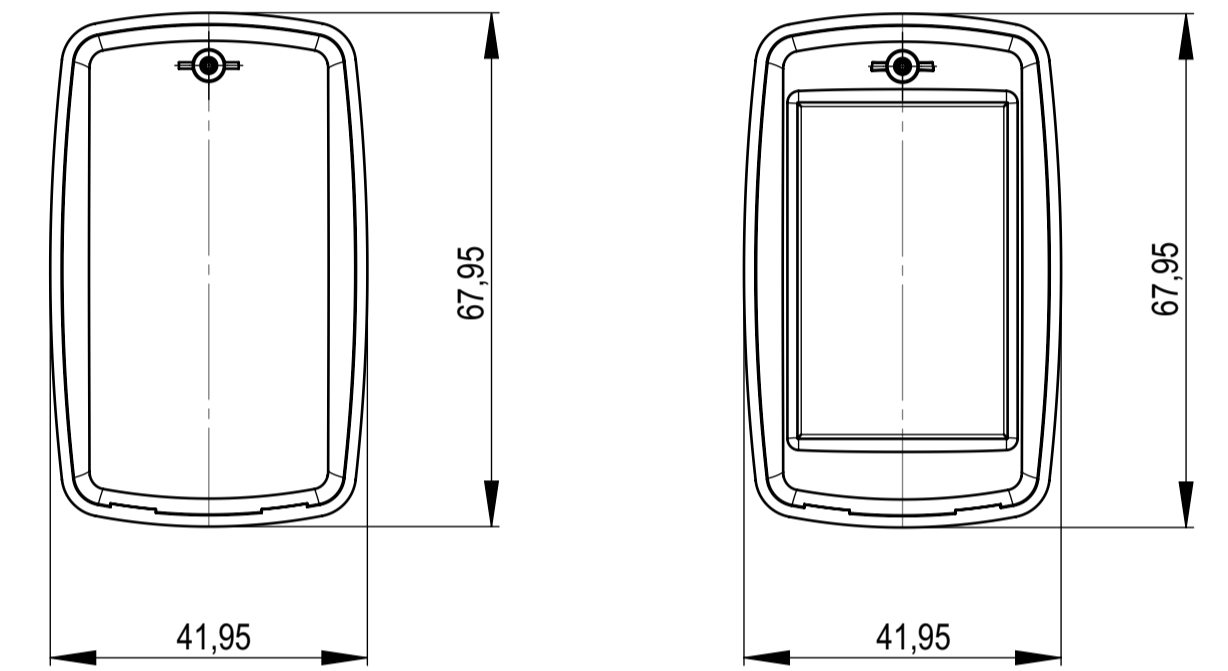

mit 1 Öse
with 1 strap loop

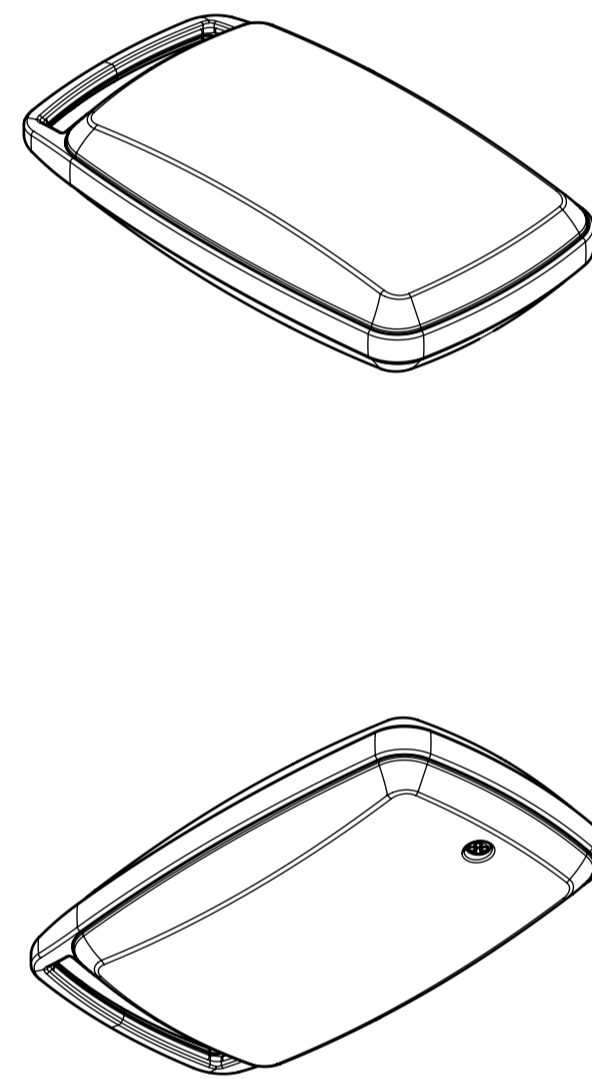
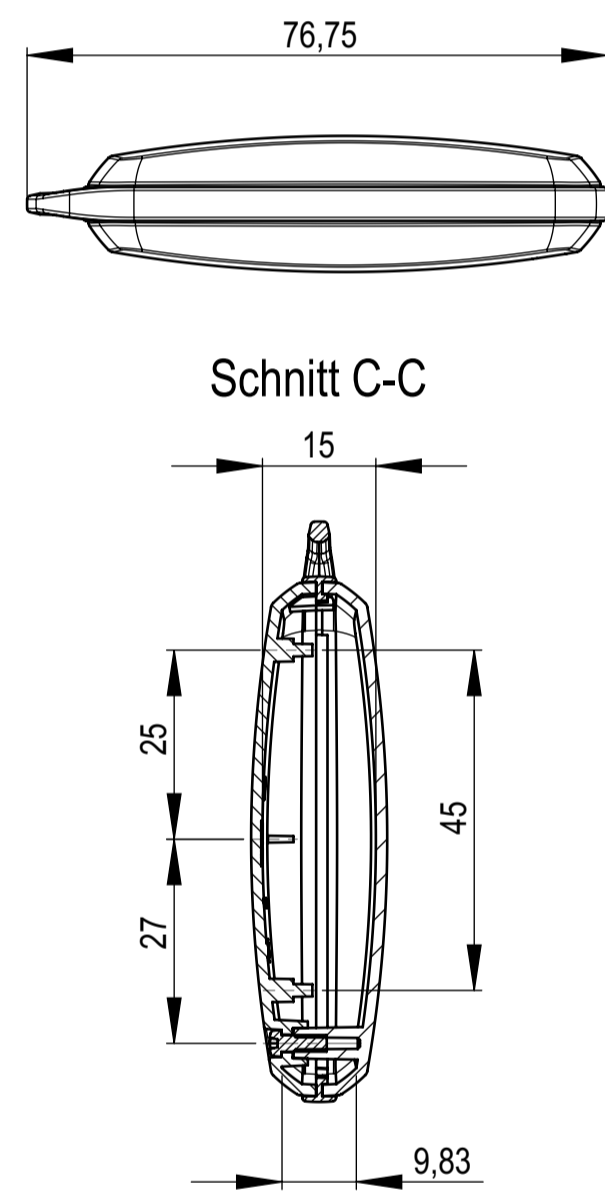
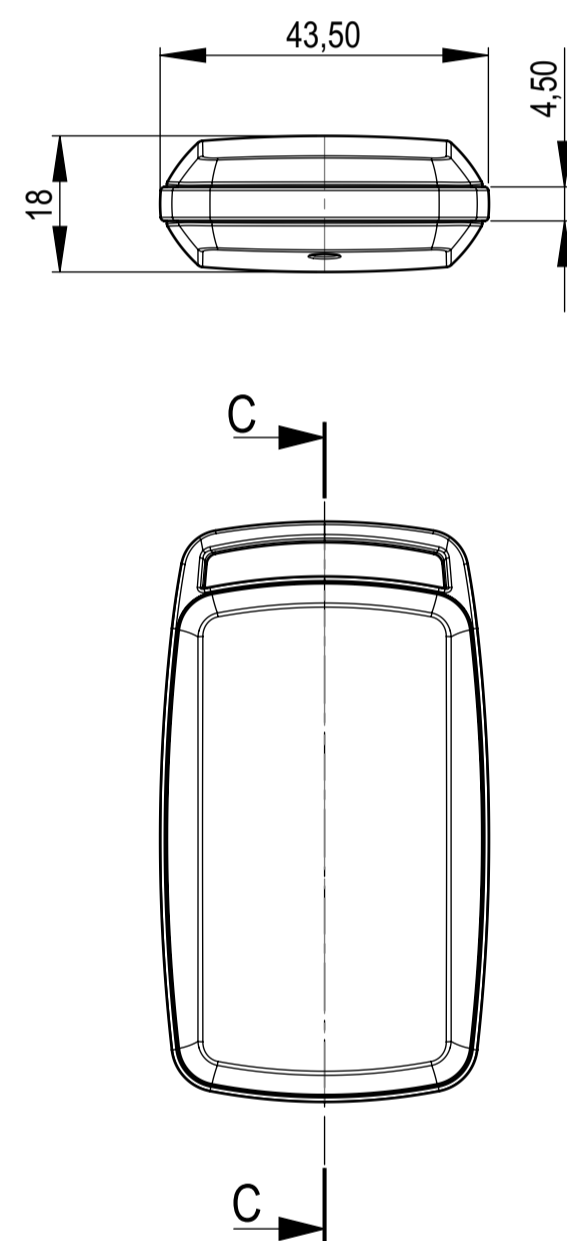

mit 1 Öse
with 1 strap loop

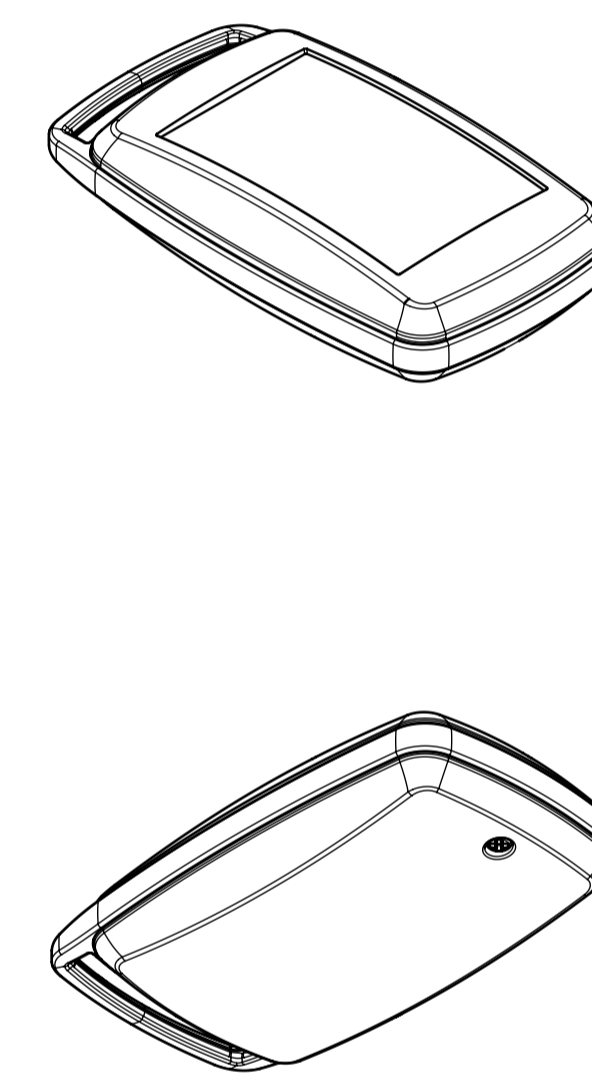
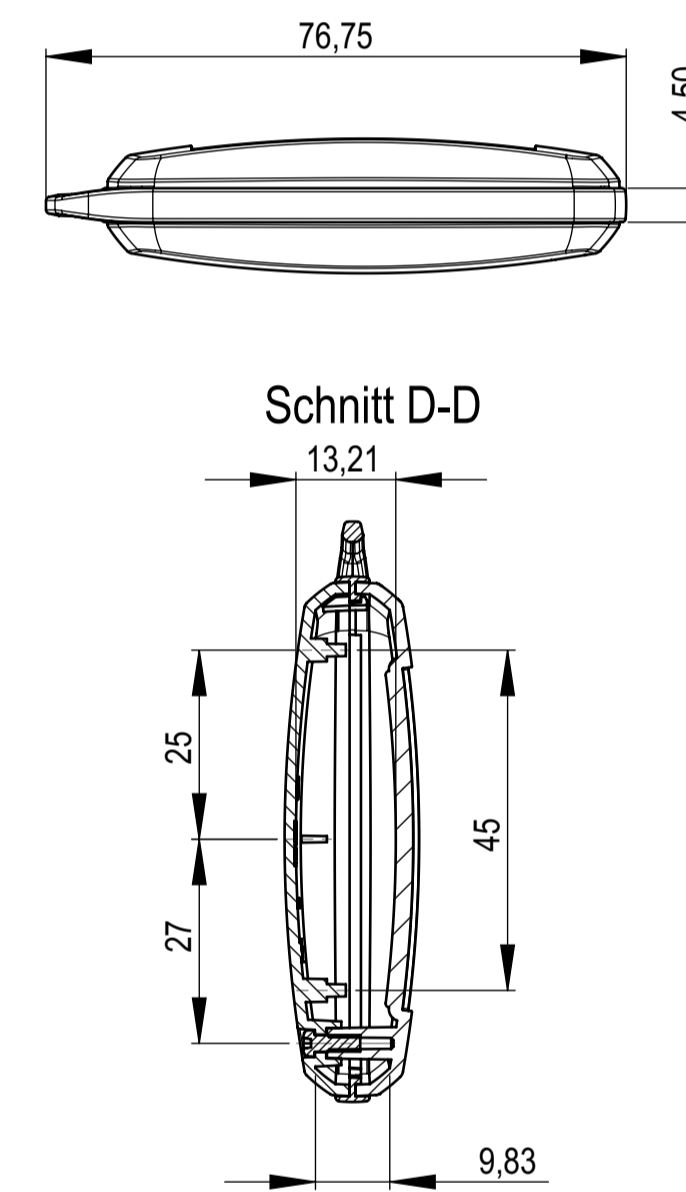
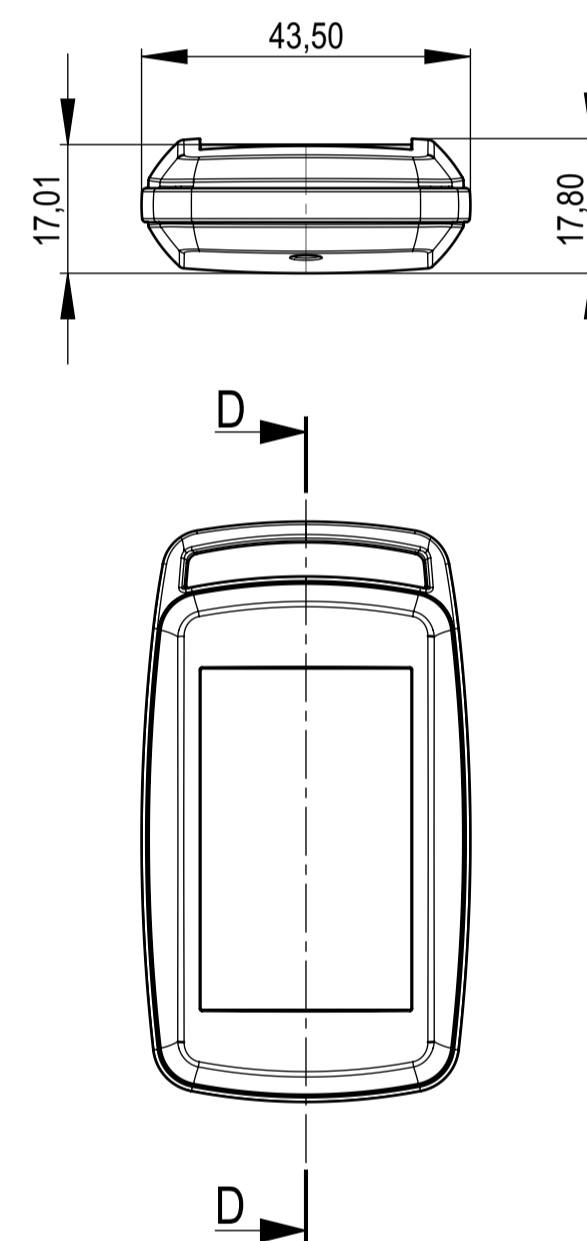

Platine UT
P C B

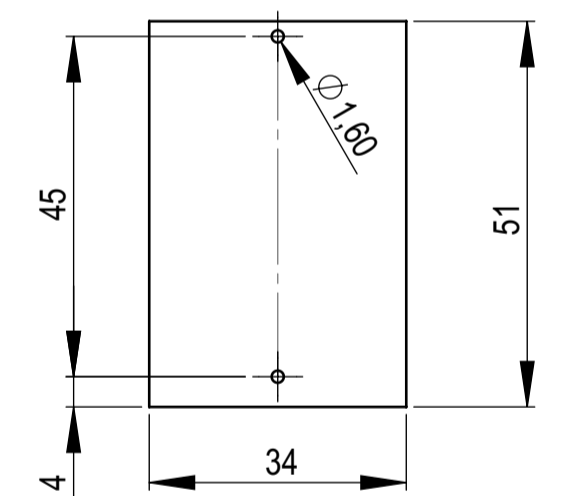

mit 2 Ösen
with 2 strap loops

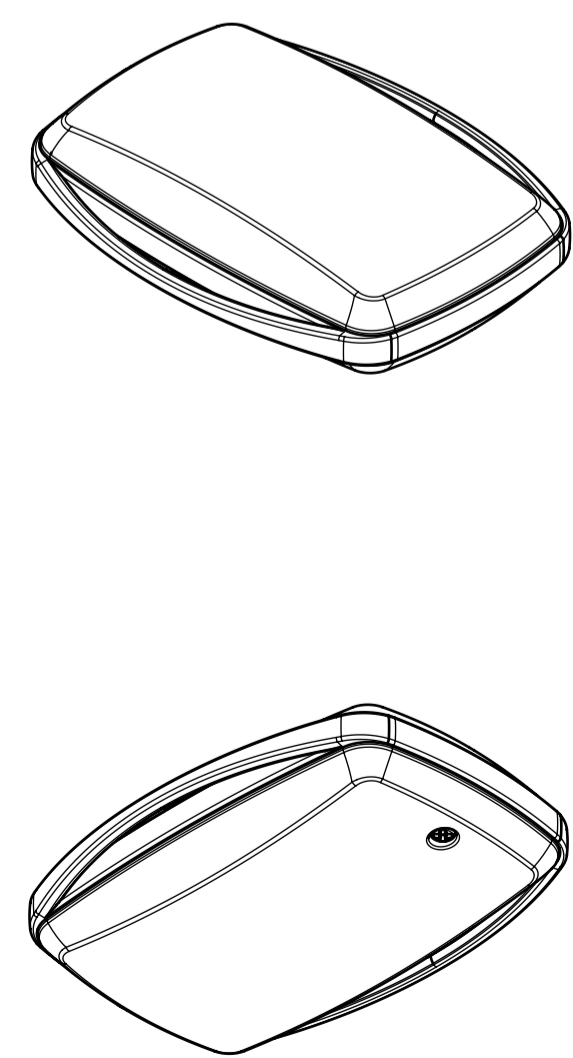
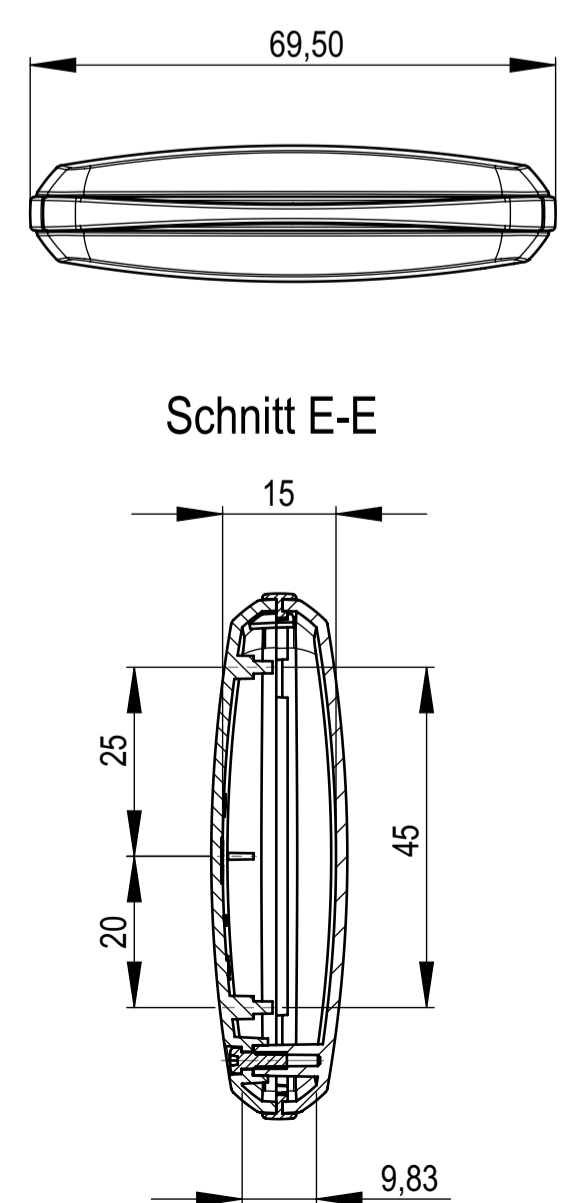
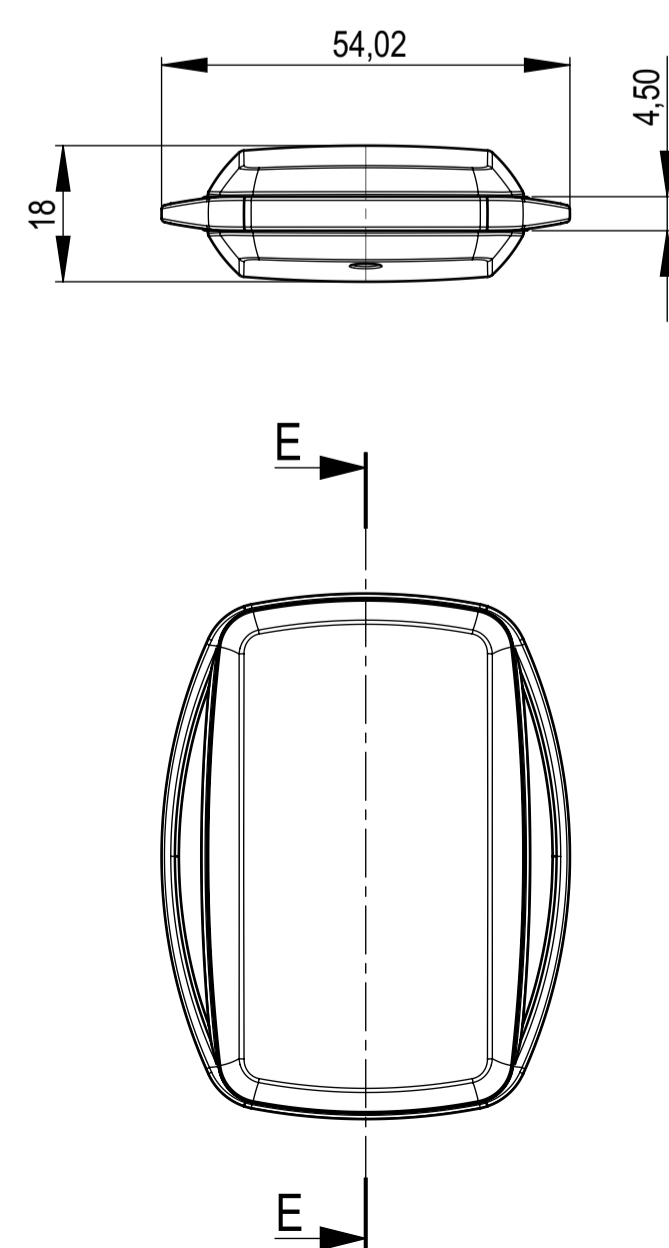

mit 2 Ösen
with 2 strap loops

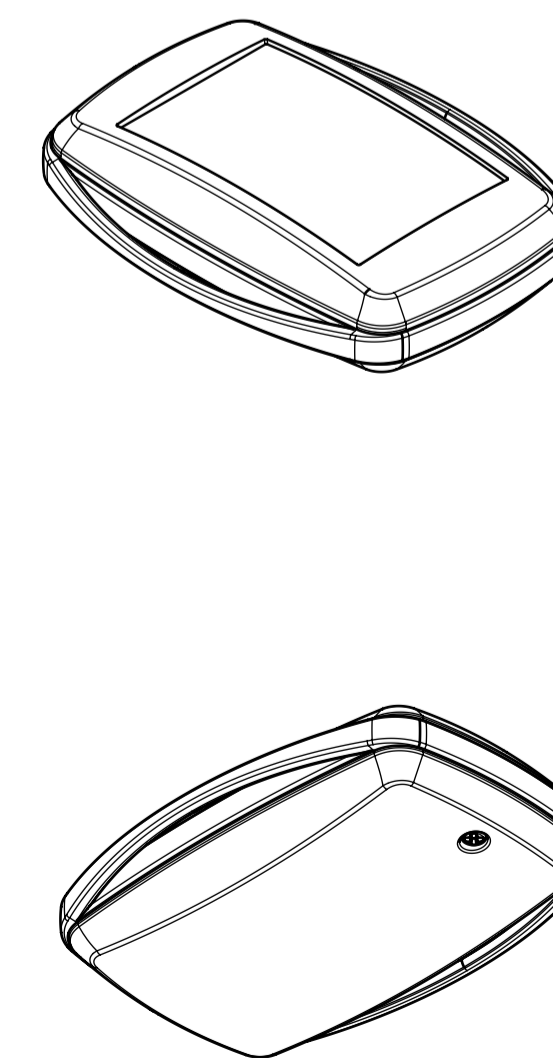
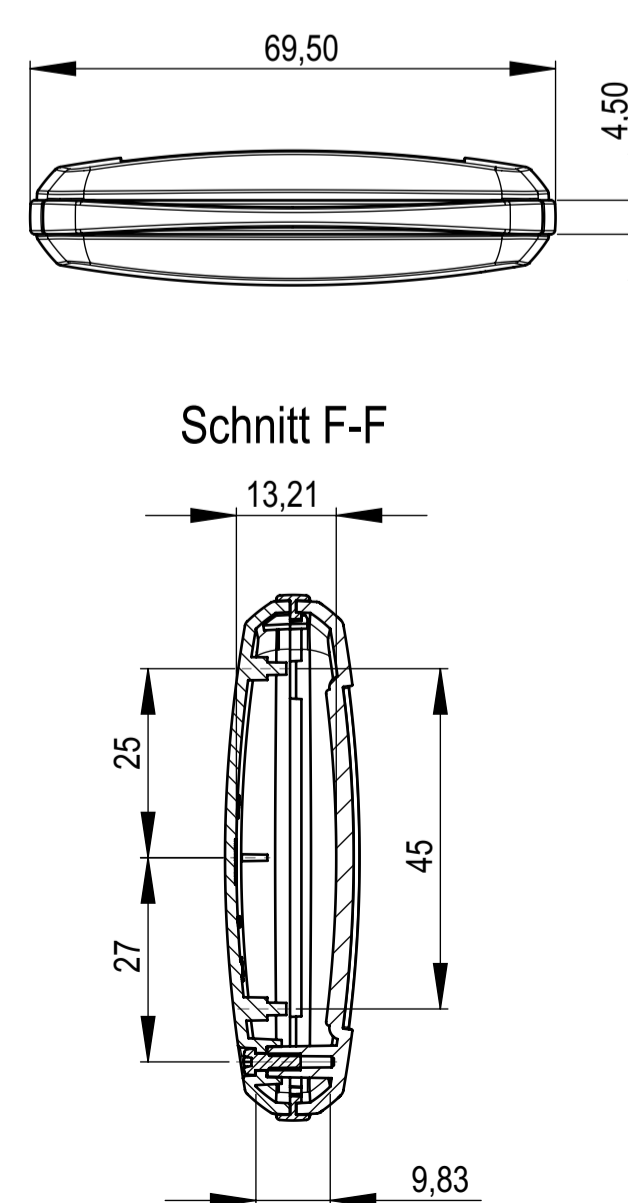
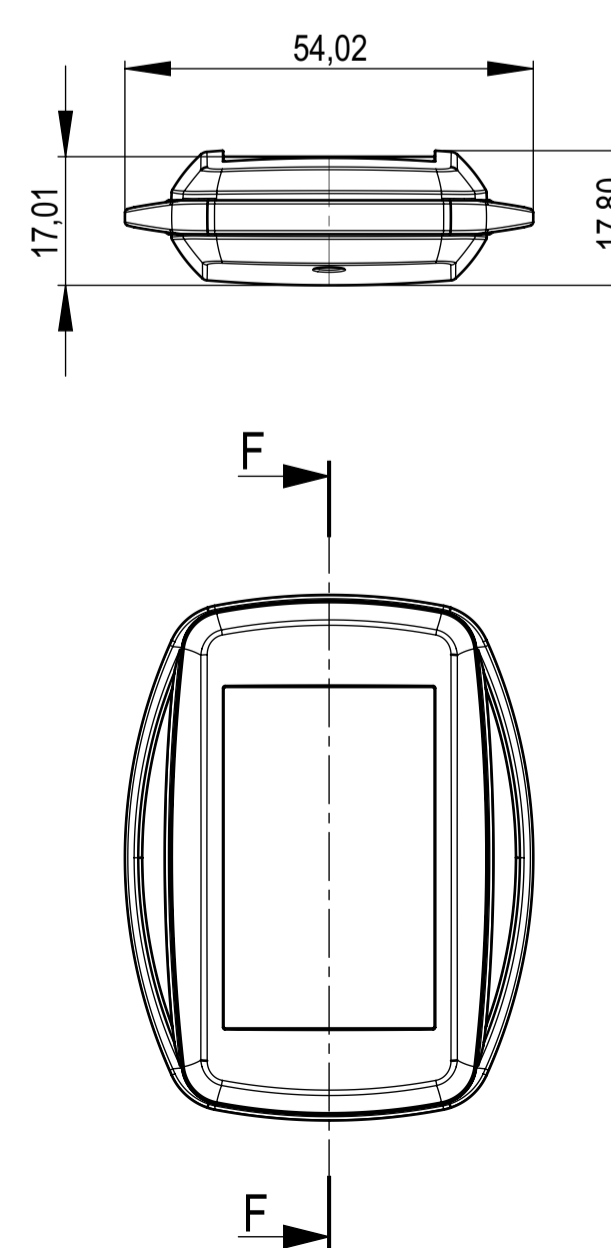

Folientastatur
membrane keyboard

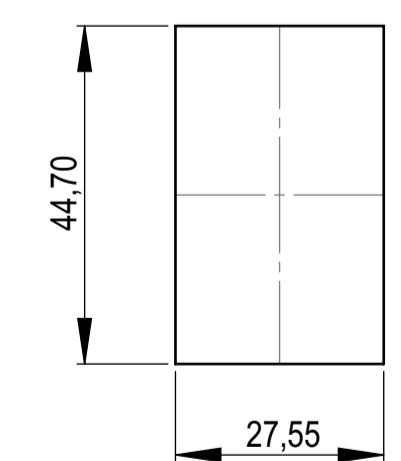

Hinweis: Zwischenring als separater Artikel B 90 04 7..
Note: intermediate ring as separate article B 90 04 7..

Informationskopie
Copy for Information
will not be updated

Erst. am: 30.09.2009
Erst. von: Herrlich
Freig. am:
Freig. von:
Revision: 02

Toleranzen:
Volumen:
Status: ÄNDERUNG
Zeichnungsart: KUNDE
DIN 6 Teil 2

Technische Änderungen vorbehalten. Irrtümer oder Druckfehler begründen keinen Anspruch auf Schadensersatz. Wichtige Einbaumaße bitte direkt mit dem aktuellen Produkt bestimmen.
Subject to technical modification without prior notice. Typographical and other errors do not justify any claim for damages. All dimensions should be verified using an actual moulded part.
Sous réserve de modifications techniques. Toute erreur ou faute d'impression ne justifie aucune demande d'indemnisation. Nous prions les clients de vérifier les dimensions des composants avec les boîtiers avant le montage.



MINITEC E M
mit Ring 1 und Ring 2
B90048**

M 1:1
Dateiname: 00011816