

Product Data Sheet

9695480316
VWEG172PJLPZ
6314NM

ebmpapst

Engineering a better life



6314NM

INDEX

- 1 General 3**
- 2 Mechanics 3**
 - 2.1 General 3
 - 2.2 Connections 3
- 3 Operating Data 4**
 - 3.1 Electrical Operating Data 4
 - 3.2 Electrical Features 5
 - 3.3 Aerodynamics 6
 - 3.4 Sound Data 7
- 4 Environment 7**
 - 4.1 General 7
 - 4.2 Climatic Requirements 7
- 5 Safety 8**
 - 5.1 Electrical Safety 8
 - 5.2 Approval Tests 8
- 6 Reliability 8**
 - 6.1 General 8

1 General

Fan type	Axial	
Rotating direction looking at rotor	Counterclockwise	
Airflow direction	Air outlet over struts	
Bearing system	Ball bearing	
Mounting position - shaft	Any	

2 Mechanics

2.1 General

Depth	51,0 mm	
Diameter	172,0 mm	
Mass	0,730 kg	
Housing material	Metal	
Impeller material	Plastic	
Max. torque when mounted across both mounting flanges	Wire outlet corner: 600 Ncm Remaining corners: 600 Ncm	
Screw size	ISO 4762 - M4 degreased, without an additional brace and without washer	

2.2 Connections

Electrical connection	Wires	
Lead wire length	L = 365 mm	
Tolerance	+ - 10,0 mm	
Tube length	S = 10 mm	
Tolerance	+ - 2,0 mm	



Wire	Color	Operation	Wire size	Insulation diameter
1	red	+ UB	AWG 22	1,7 mm
2	blue	- GND	AWG 22	1,7 mm

The auxiliaries shown on the schematic diagram (which are required for the intended use) are not part of our delivery.

3 Operating Data

3.1 Electrical Operating Data

Measurement conditions: Normal air density = 1,2 kg/m³; Temperature 23°C +/- 3°C; Motor axis horizontal; warm-up time before measuring 5 minutes (unless otherwise specified). In the intake and outlet area should not be any solid obstruction within 0,5 m.

$\Delta p = 0$: corresp. to free air flow (see chapter aerodynamics)

I: corresp. to arithm. mean current value

>90% PWM; f = 2 kHz or broken lead wire (open control input)

Features	Condition	Symbol	Values		
Voltage range		U	16 V		32 V
Nominal voltage		U _N		24,0 V	
Power consumption	$\Delta p = 0$	P	5,8 W	9,5 W	10,5 W
Tolerance	0010		+/- 10,0 %	+/- 10,0 %	+/- 10,0 %
Current consumption	$\Delta p = 0$	I	360 mA	400 mA	320 mA
Tolerance	0010		+/- 10,0 %	+/- 10,0 %	+/- 10,0 %
Speed	$\Delta p = 0$	n	2.000 1/min	2.500 1/min	2.500 1/min
Tolerance	0010		+/- 10,0 %	+/- 10,0 %	+/- 10,0 %

3.2 Electrical Features

Electronic function	None	
Reversed polarity protection	Rectifying diode	
Max. residual current at U_N	$I_F \leq 5 \text{ mA}$	
Locked rotor protection	Auto restart	
Locked rotor current at U_N	I_{block} approx. 1.000 mA	
Clock signal at locked rotor	t_3 / t_4 typical: 0,5 s / 10,0 s	

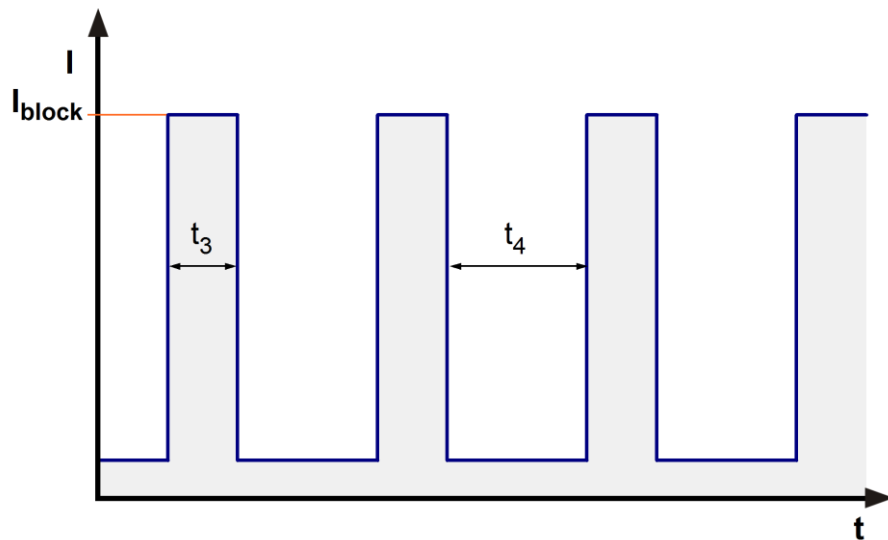

This fan has a startup delay of 2,2 seconds after applying supply voltage.

Internal Fuse: Littelfuse Nano2 Fuse Very Fast-Acting 451/453 Series 4A / 75V

3.3 Aerodynamics

Measurement conditions:

Measured with a double chamber intake rig acc. to DIN EN ISO 5801.
Normal air density = 1,2 kg/m³; Temperature 23°C +/- 3°C;
In the intake and outlet area should not be any solid obstruction within 0,5 m. Motor shaft horizontal.
The information is only valid under the specified test conditions and may be changed by the installation conditions. If there are deviations from the standard test conditions, the characteristic values must be checked under the installed conditions. Power consumption of the fan motor when operating at normal voltage is shown. Depending on the operating conditions of the application, the power input may be higher.

a.) Operation condition:

2.500 1/min at free air flow

Max. free-air flow ($\Delta p = 0 / \dot{V} = \text{max.}$)	330 m ³ /h	
Max. static pressure ($\Delta p = \text{max.} / \dot{V} = 0$)	140 Pa	

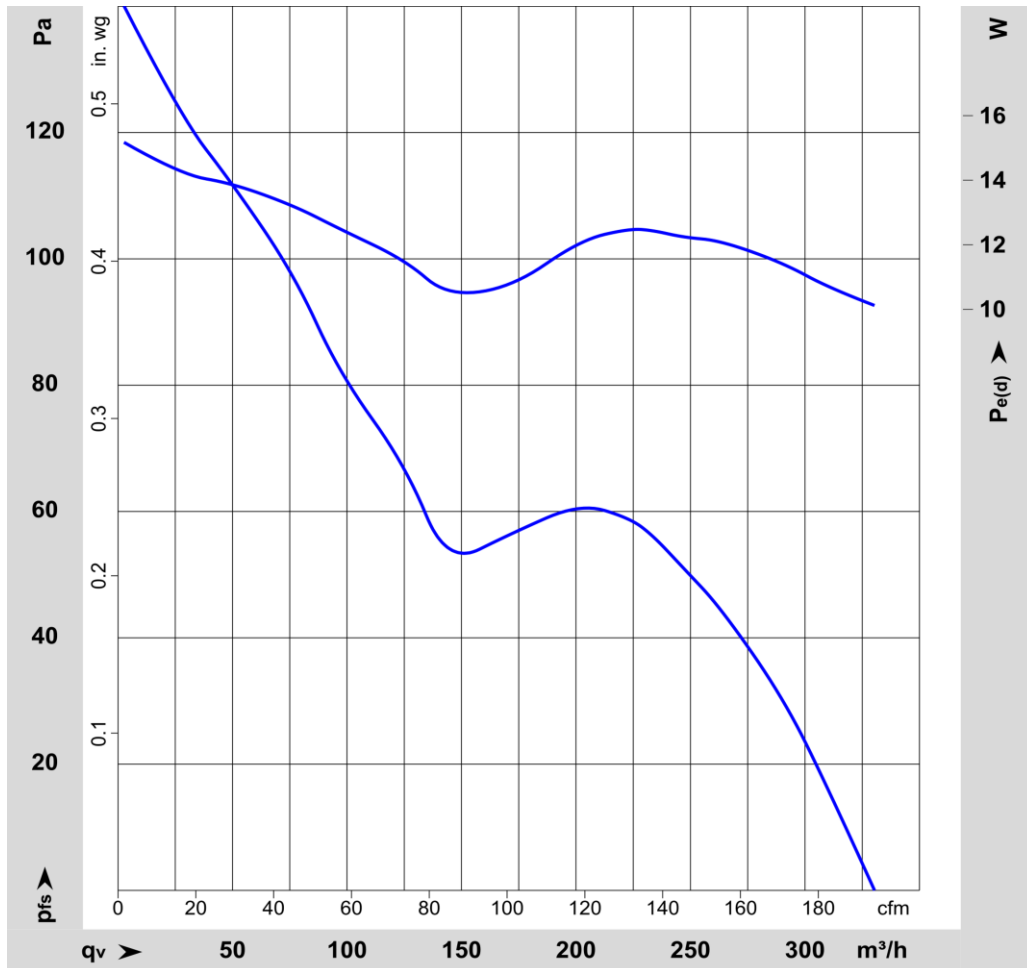

3.4 Sound Data

Measurement conditions: Sound pressure level: 1 meter distance between microphone and the air intake.
Sound power level: According to ISO 13347-3.
Measured in a semianechoic chamber with a background noise level of $L_p(A) < 5 \text{ dB(A)}$
For further measurement conditions see chapter aerodynamics.

a.) Operation condition:

2.500 1/min at free air flow

Optimal operating point	232 m ³ /h @ 57 Pa	
Sound power level at the optimal operating point	5,7 bel(A)	
Sound pressure level at free air flow, measured in rubber bands	49 dB(A)	

4 Environment

4.1 General

Min. permitted ambient temperature TU min.	-20 °C	
Max. permitted ambient temperature TU max.	70 °C	
Min. permitted storage temperature TL min.	-40 °C	
Max. permitted storage temperature TL max.	80 °C	

4.2 Climatic Requirements

Humidity requirements	humid heat, constant; according to DIN EN 60068-2-78, 14 days	
Water exposure	None	
Dust requirements	None	
Salt fog requirements	None	

Permitted application area:

The product is intended for use in sheltered rooms with controlled temperature and controlled humidity. Directly exposure to water must be avoided.

Pollution degree 1 (according DIN EN 60664-1)

There is either no pollution or it occurs only dry, non-conductive pollution. The pollution has no negative impact.

Please require severity levels and specification parameters from the responsible development departments.

5 Safety

5.1 Electrical Safety

Dielectric strength DIN EN 62368 and DIN EN 60335 A.) Type test Measuring conditions: After 48h of storage at 95% R.H. and 25°C. No arcing or breakdown is allowed! All connections together to ground. B.) Routine test Measuring conditions: At indoor climate. No arcing or breakdown is allowed! All connections together to ground.	1000 VAC / 1 Min. 1700 VDC / 1 Sec.	
Isolation resistance Measuring conditions: After 48h of storage at 95% R.H. and 25°C measured with U=500 VDC for 1 min.	RI > 10 MOhm	
Clearance / creepage distance	1,0 mm / 1,5 mm	
Protection class	III	

5.2 Approval Tests

CE	EC Declaration of Conformity	No
EAC	Eurasian Conformity	Yes
UL	Underwriters Laboratories	Yes
VDE	Association for Electrical, Electronic and Information Technologies	Yes
CSA	Canadian Standards Association	Yes
CCC	China Compulsory Certification	Not applicable

6 Reliability

6.1 General

Life expectancy L10 at TU = 40 °C	80.000 h	
Life expectancy L10 at TU max.	40.000 h	
Life expectancy L10 acc. to IPC 9591 at TU = 40 °C	135.000 h	

Copyright of this document, and design, is reserved. It shall not be used or reproduced in any form without the written consent of ebmpapst. All rights are reserved in the event of the part of a patent or the registration of a utility model or design.

Sonderdruck nach DIN ISO 9016 (revisions /
 Sonderdruck nach DIN ISO 9016 (revisions /
 Sonderdruck nach DIN ISO 9016 (revisions /

3) Schraube: Duo-Tapfite nach
 DIN 7500, CM 4x8, Torx /
 screw: Duo-Tapfite according to
 DIN 7500, CM 4x8, Torx

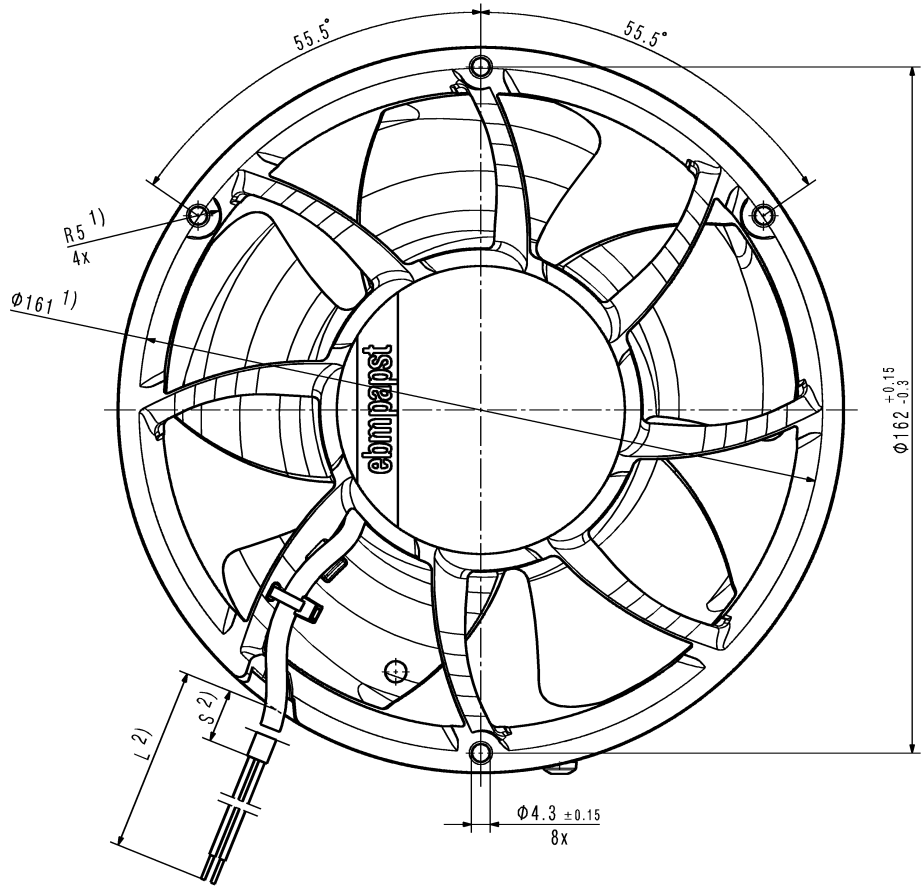
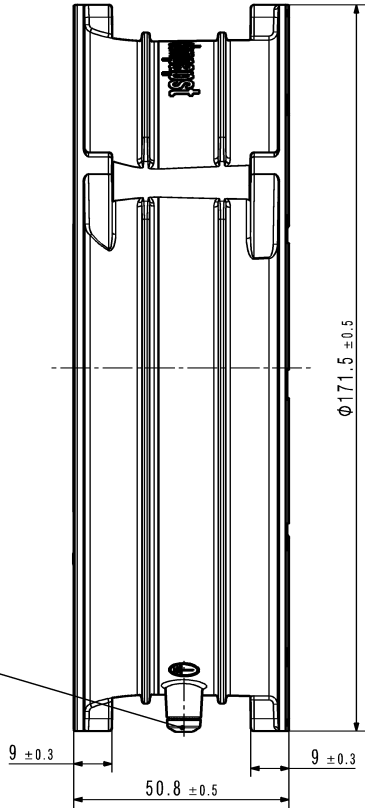

- 1) Maße aus Montageausschnitt
- 2) Anzahl und Länge der Litzen/Schlauch siehe Produktspezifikation
- 3) Erdungsschraube nur wenn in der Lueftergehaeusestueckliste enthalten

- Axialspiel der Kugellager mit Feder spielfrei gelagert

- 1) measures of mounting cut out
- 2) length an number of wires/tube see product specification
- 3) grounding screw only if contained in the fan housing part list

- ball bearing without clearance by a pre-load spring

Dokument-Status / Document-State		CATIA-Version/ CATIA-Version	CAO-Integration/ CAO-Environment	Werkstoff / Material:	Volumen / Volume (cm³):
		999548000 CPM000			Gewicht / Mass (g):
Aend.-Nr. / Change-No.		3D-Referenzmodell / 3D-ReferenceModel		Artikel / Title:	
Tolerierung / Tolerances:		Datum	Name		
Allgemeintoleranzen / Gen. Tolerances:		Bearb. / Drawn		Zug.-Nr. / Drawing No:	Ers.f.-Zug. / Replaces:
		Gepr. / Checked			
		Freig. / Released			
		ebmpapst		Dokumenttyp / Type of Document	Tei/Lockument (Blatt/Page)
		ebm-papst St. Georgen GmbH & Co KG		Index / Index:	Format / Size:
					Masstab/Scale