



Service cart

Version 03/15

Item no. 1296213

Intended use

The product is designed for home and hobby shop use and is equipped with two plastic shelves. The service cart can be moved optimally and parked securely by means of four castors (two of them with brakes).

The service cart comes disassembled and must be assembled in order to work. This is done in only a few steps.

Please read these operating instructions carefully to ensure safe use and operation of the product. Keep these operating instructions in a safe place for future reference. Always observe the safety instructions and all other information included in these operating instructions.

Any use other than that described above is not permitted and can lead to damage of this product; this can also lead to danger for the user.

This product meets applicable national and European requirements. All names of companies and products are the trademarks of the respective owners. All rights reserved.

Explanation of symbols



This symbol points to specific risks associated with handling, function and use.



The "Hand" symbol indicates special tips and operating information.

Package contents

• Service cart (disassembled)

A 1x top deck

B 1x bottom deck (including threads for castors)

C 2x handle

D 4x aluminium profile tube

E 2x castor with brake

F 2x castor

G 1x open-end wrench

H 4x snap ring

• Operating instructions

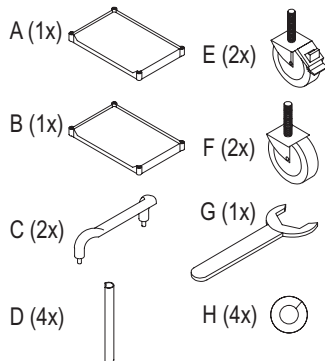

Safety instructions



The warranty/guarantee will be void in the event of damage caused by failure to observe these operating instructions! We do not assume any liability for any resulting damage!

We do not assume any liability for material and personal damage caused by improper use or non-compliance with the safety instructions! In such cases, the warranty will be null and void.

- For safety reasons, any unauthorised conversion and/or modification to the product is not permitted.
- The product is not a toy and it should be kept out of the reach of children.
- Never overload the product. The permitted load capacity is max. 30 kg per deck (do not accumulate load in one place!).
- Do not use to transport persons.
- Always place the service cart in such a way that it cannot tilt over or roll away.
- Always lock both brakes of the castors when you don't move the service cart. This applies especially when the ground is uneven or sloppy.
- While you push, keep hold of the service cart; never let it move on its own.
- In schools, educational centres, hobby and self-help workshops, the use of the product is to be supervised by trained employees in a responsible manner.
- Do not leave the packaging material carelessly lying around, as it could become a dangerous plaything for children.
- If you are in doubt about how to use the service cart correctly, or if you have any questions not covered by these operating instructions, please contact our technical support or any other specialist.

Assembly

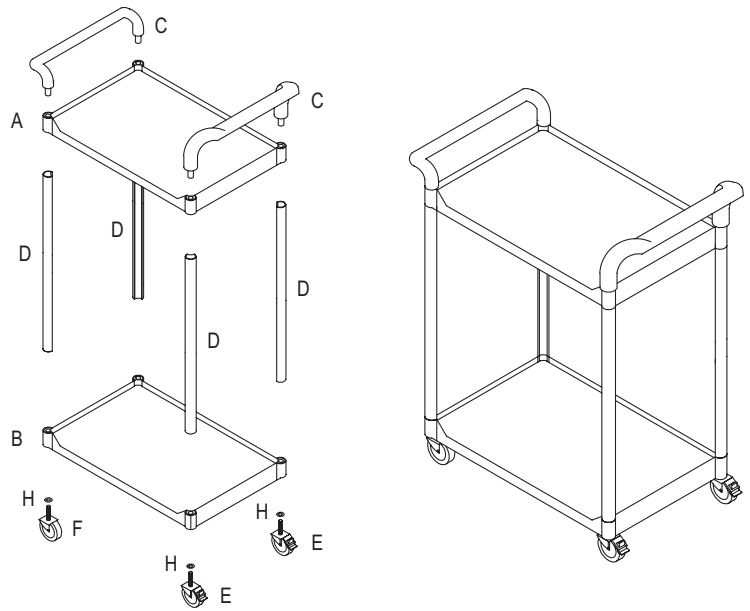

Step 1:

First insert the four aluminium profile tubes (D) into the bottom deck (B). By means of a rubber mallet, tap the section tubes gently into the corresponding slots on the deck.



If you do not have a rubber mallet, you may use a conventional hammer and a suitable padding such as a piece of soft wood. Place the wood on the section tube and then tap the section tube gently into the corresponding slot on the lower bottom deck.



Do not apply excessive force, which may damage the aluminium profile tubes or plastic decks and thus resulting in loss of guarantee/ warranty!

Step 2:

Place the top deck (A) on the four section tubes (D). Proceed as described in step 1 and insert the section tubes into the slots on the top deck.

Step 3:

Insert the two plastic handle brackets (C) into the openings of the top deck (A) until they lock in place. Both handles must point outward.

Step 4:

Turn the service cart upside down at 180°.

Put a snap ring (H) on each of the threads of the four castors (E + F).

One after the other drive in the four castors (E + F) into the appropriate threads on the bottom deck (B). Make use of the flat metal wrench (G).



The castors equipped with a brake (E) can be driven in at the longitudinal or the transverse side, depending where and how you intend to use the service cart.

Turn the service cart over so that it is standing on the for castors. The service cart is now ready for use.

Cleaning

Clean the product only with a soft, clean, dry cloth. For heavier soiling, you can moisten the cloth with lukewarm water.

Do not use aggressive, chemical or scouring cleaning agents, as this may lead to discolouration or changes in the material on the surface.

Technical data

Load capacity of the bottom deck.....max. 30 kg (no punctiform load)

Load capacity of the top deck.....max. 30 kg (no punctiform load)

Dimensions.....900 x 500 x 970 mm (L x W x H)

Weight:9.4 kg