

# Spezifikation für Freigabe / specification for release

Kunde / customer :  
 Artikelnummer / part number :

**7497011611A**



Bezeichnung : **LAN-Übertrager WE-RJ45LAN 10/100BaseT**  
 description : **LAN-Transformer WE-RJ45LAN 10/100BaseT**

DATUM / DATE : 2015-04-16

## A Mechanische Abmessungen / dimensions :

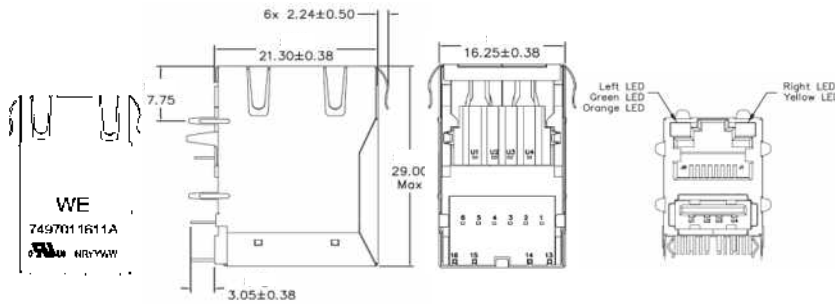

## B Lötpad / soldering spec. :

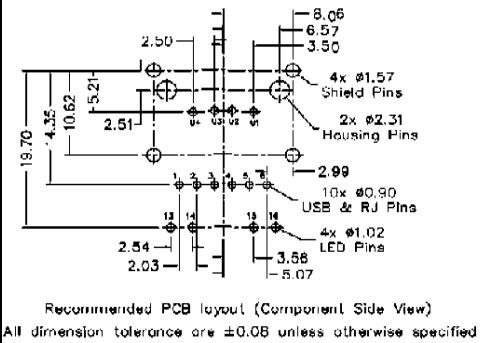

## C Elektrische Eigenschaften / electrical properties :

Eigenschaften / properties	Testbedingungen / test conditions		Wert / value	Einheit / unit	tol.
Induktivität / Inductance	100kHz / 100mV @ 8mA DC-Bias	OCL	350	µH	min.
Übersetzungsverhältnis / Turns ratio	100kHz / 100mV	TR	1 : 1	Tx	#####
			1 : 1	Rx	
Insertion Loss	1-100MHz	IL	-1,0	dB	max.
Return Loss	1-30MHz	RL	-18	dB	min.
	30-45MHz		-16,0		
	45-60MHz		-13,5		
	60-80MHz		-12		
Common Mode Rejection	1-100MHz	CMR	-30	dB	min.
Crosstalk	1-100MHz	CT	-30	dB	min.

## Suggested panel opening

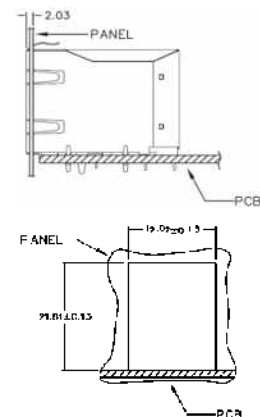

## D Prüfgeräte / test equipment :

Agilent E5071C

## E Testbedingungen / test conditions :

Luftfeuchtigkeit / humidity: 33%  
 Umgebungstemperatur / temperature: +25°C

## F Werkstoffe & Zulassungen / material & approvals :

Basismaterial / base material: Ferrit/ ferrite  
 Draht / wire: QPN 180°C  
 Kontaktmaterial/ contact plating: 100% tin w. nickel underplating 30µ"gold plating on contact area  
 Gehäuse / housing: Thermoplastic UL 94V-0  
 LED: 1,8-2,8 V/ 20mA  
 Shield: 50µ" nickel over 0.01" cooper alloy

## G Eigenschaften / general specifications :

Betriebstemp. / operating temperature: -40°C - +85°C  
 Hochspannungsprüfung / Hipot test: 1500Vrms 1min.  
 Geeignet für 10/100Base-TX gemäß IEEE 802.3u / Compliant with IEEE 802.3u for 10/100Base-TX-Applications  
 Auto MDIX fähig / Auto MDIX capable

Freigabe erteilt / general release:	<b>Kunde / customer</b>		
.....			
Datum / date	Unterschrift / signature		
	<b>Würth Elektronik</b>		
.....			
Geprüft / checked	Kontrolliert / approved	JaB	Revision 00
		Name	Änderung / modification
			Datum / date

## Würth Elektronik eiSos GmbH & Co.KG

D-74638 Waldenburg · Max-Eyth-Straße 1 - 3 · Germany · Telefon (+49) (0) 7942 - 945 - 0 · Telefax (+49) (0) 7942 - 945 - 400  
 http://www.we-online.com

# Spezifikation für Freigabe / specification for release

Kunde / customer :  
 Artikelnummer / part number : **7497011611A**  
 Bezeichnung : **LAN-Übertrager WE-RJ45LAN 10/100BaseT**  
 description : **LAN-Transformer WE-RJ45LAN 10/100BaseT**



DATUM / DATE : 2015-04-16

## H Schaltbild / Schematics :

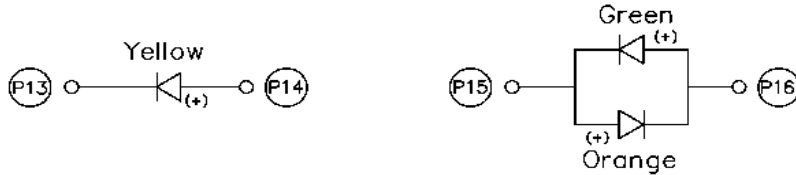
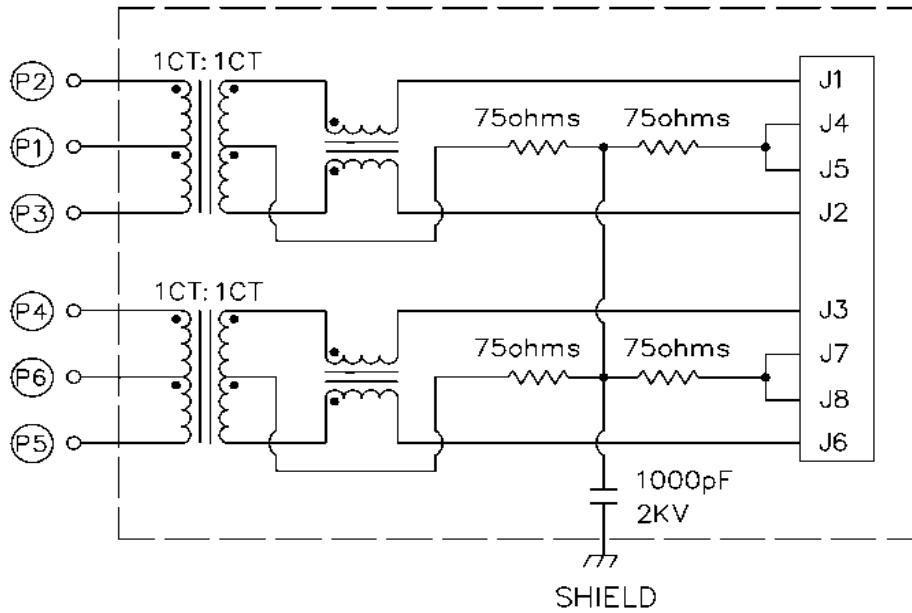

Freigabe erteilt / general release:	<b>Kunde / customer</b>			
.....	.....			
Datum / date	Unterschrift / signature			
.....	<b>Würth Elektronik</b>			
.....	.....			
Geprüft / checked	Kontrolliert / approved	JaB	Revision 00	2015-04-16
		Name	Änderung / modification	Datum / date

### Würth Elektronik eiSos GmbH & Co.KG

D-74638 Waldenburg · Max-Eyth-Straße 1 - 3 · Germany · Telefon (+49) (0) 7942 - 945 - 0 · Telefax (+49) (0) 7942 - 945 - 400  
<http://www.we-online.com>

# Spezifikation für Freigabe / specification for release

Kunde / customer :  
 Artikelnummer / part number : **7497011611A**  
 Bezeichnung : LAN-Übertrager WE-RJ45LAN 10/100BaseT  
 description : LAN-Transformer WE-RJ45LAN 10/100BaseT



DATUM / DATE : 2015-04-16

## I Verpackungsspezifikation / package specification :

Tray

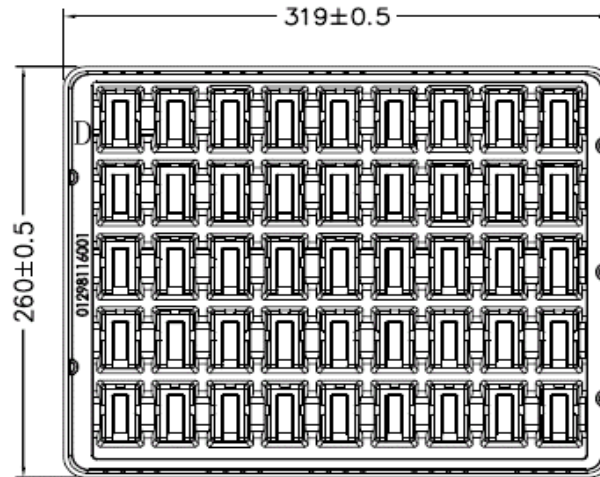

Carton

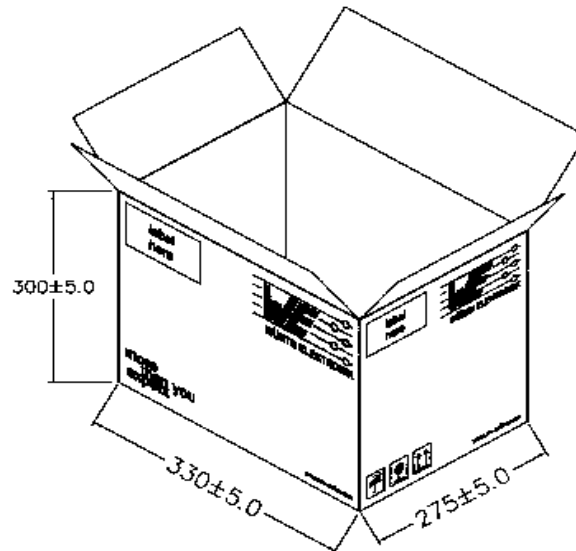

**Package Quantity:**

tray = 60 pcs  
 carton = 480 pcs

**dimensions in mm**

Freigabe erteilt / general release:	Kunde / customer			
Datum / date	Unterschrift / signature			
	Würth Elektronik			
Geprüft / checked	Kontrolliert / approved	JaB	Revision 00	2015-04-16
		Name	Änderung / modification	Datum / date

This electronic component has been designed and developed for usage in general electronic equipment. Before incorporating this component into any equipment where higher safety and reliability is especially required or if there is the possibility of direct damage or injury to human body, for example in the range of aerospace, aviation, nuclear control, submarine, transportation, (automotive control, train control, ship control), transportation signal, disaster prevention, medical, public information network etc, Würth Elektronik eiSos GmbH must be informed before the design-in stage. In addition, sufficient reliability evaluation checks for safety must be performed on every electronic component which is used in electrical circuits that require high safety and reliability functions or performance.

**Würth Elektronik eiSos GmbH & Co.KG**

D-74638 Waldenburg · Max-Eyth-Straße 1 · 3 · Germany · Telefon (+49) (0) 7942 - 945 - 0 · Telefax (+49) (0) 7942 - 945 - 400  
<http://www.we-online.com>