



LENGTH-ADJUSTABLE TWIST LEVER FOR
POSITION SWITCH 3SE51/52 METAL LEVER 100MM
LONG STAINLESS STEEL ROLLER 19MM

Product designation		actuator for part-turn actuator
Manufacturer article number		
<ul style="list-style-type: none"> of the supplied operating lever 		3SE5000-0AA51

General technical data:

Product function		
<ul style="list-style-type: none"> positive opening 		No
Shock resistance		30g / 11 ms
Vibration resistance		0.35 mm / 5g
Mechanical service life (switching cycles)		
<ul style="list-style-type: none"> typical 		15 000 000
Equipment marking		
<ul style="list-style-type: none"> acc. to DIN EN 61346-2 		T
<ul style="list-style-type: none"> acc. to DIN EN 81346-2 		T
Active principle		mechanical
Explosion protection category for dust		none
Explosion protection category for gas		none

Enclosure:

Coating of the enclosure		Other types
---------------------------------	--	-------------

Drive Head:

Design of the operating mechanism		metal lever, adjustable length, stainless steel roller 19 mm
Shape of the switch head		roller
Outer diameter of the switch head	mm	19

Communication/ Protocol:

Design of the interface		without
-------------------------	--	---------





Ambient conditions:

Ambient temperature		
• during operation	°C	-25 ... +85
• during storage	°C	-40 ... +90

Installation/ mounting/ dimensions:

mounting position		any
Mounting type		screw fixing

Certificates/ approvals:

General Product Approval	Declaration of Conformity	Test Certificates	other
 CSA	 UL		 EG-Konf.
		Special Test Certificate	Confirmation

Further information

Information- and Downloadcenter (Catalogs, Brochures,...)

<http://www.siemens.com/industrial-controls/catalogs>

Industry Mall (Online ordering system)

<http://www.siemens.com/industrymall>

Cax online generator

<http://support.automation.siemens.com/WW/CAXorder/default.aspx?lang=en&mlfb=3SE5000AA51>

Service&Support (Manuals, Certificates, Characteristics, FAQs,...)

<http://support.automation.siemens.com/WW/view/en/3SE5000AA51/all>

Image database (product images, 2D dimension drawings, 3D models, device circuit diagrams, EPLAN macros, ...)

http://www.automation.siemens.com/bilddb/cax_de.aspx?mlfb=3SE5000AA51&lang=en

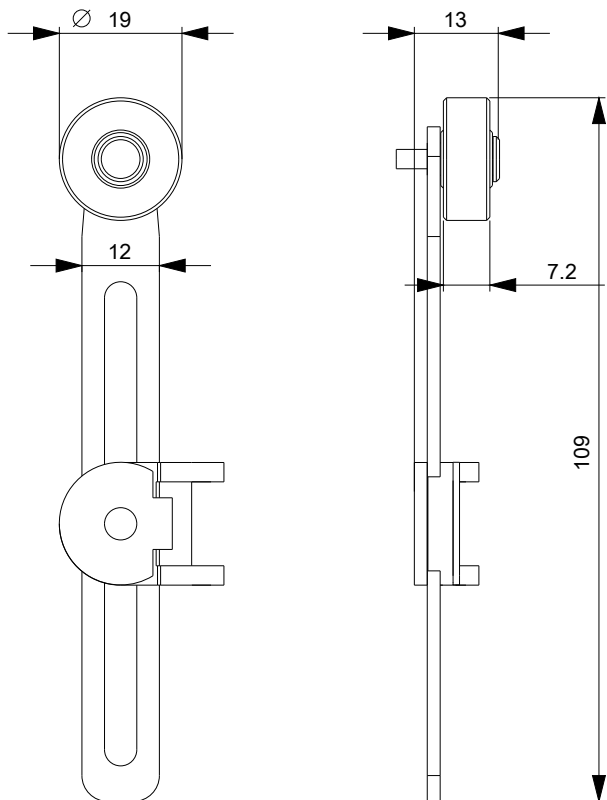

last modified:

16.03.2015