

Motor-Spannschienenensätze SPS aus Stahl, mit versetzbaren Spannklöben

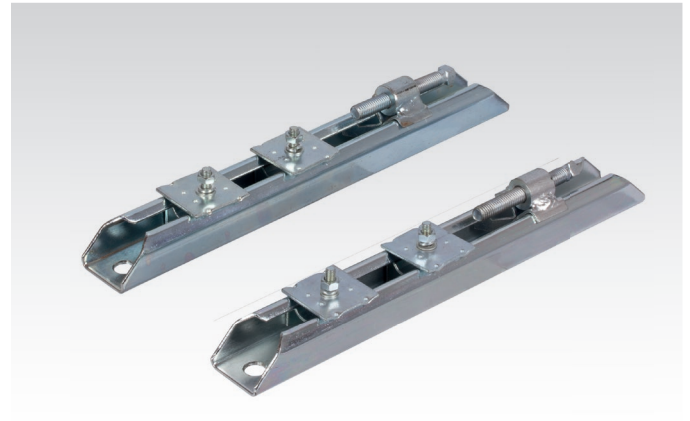
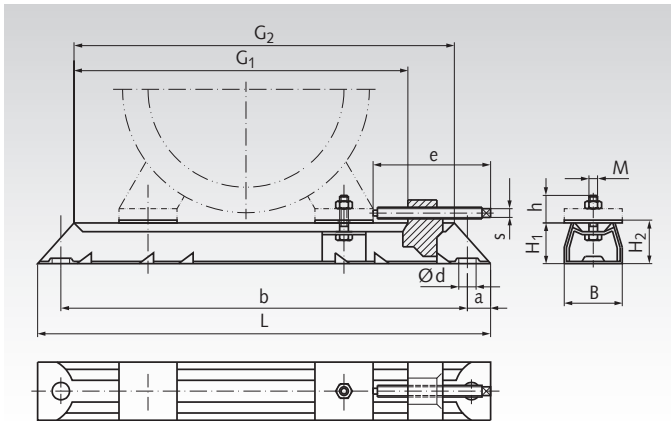

Bestellangaben: z.B.: Typenbezeichnung, Gesamtlänge, Artikel-Nr.

Verkauf paarweise: 1 x Artikel-Nr. = 1 Paar

Artikel-Nr. Paar	Gesamtlänge L mm	Gleitlänge G ₁ mm	Motor-Baugröße	M x h mm	e x S mm	G ₂ mm	a mm	b mm	Ød mm	B mm	H ₁ mm	H ₂ mm	Gewicht kg
430 180 00	312	240	63/71	M6 x 19	84 x 10	262	16	280	12	40	28	30	1,5
430 182 00	395	302	80/90	M8 x 35	106 x 12	325	20	355	12	50	40	43	3,3
430 184 00	495	405	100/112/132	M10 x 35	97 x 9	425	20	455	12	50	40	43	4,15
430 186 00	630	515	132	M10 x 37	138 x 24*	542	25	580	14	60	50	54	8,1

* Sechskantschraube mit SW24.

Frequenzumrichter
Seite 919



Bauformen Stirnradtriebmotoren (Die Abb. stellen nur die Bauformen, nicht die Getriebeausführungen dar.)

B 3

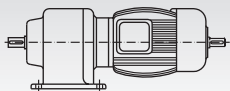

B 3 / B 5

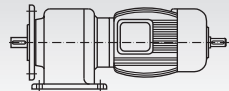

B 8 / B 5

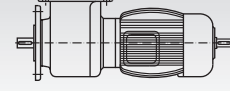

B 5

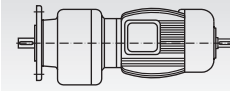

B 5a

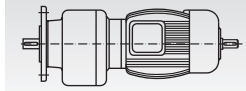

B 5 ohne Flansch

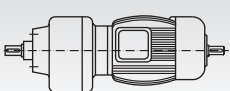

B 6

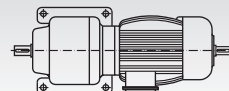

B 7

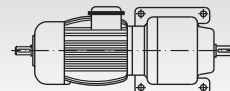

B 8

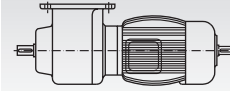

V 1

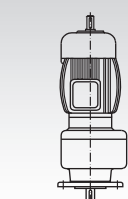

V 1 / V 5

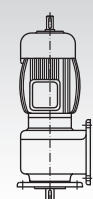

V 3

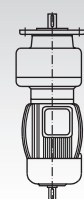

V 3 / V 6

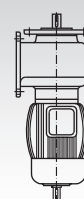

V 5



V 6

