

NOTES:

1. MATERIALS AND FINISHES:
 BODY, CLAMP NUT, WASHERS,
 OUTER CONTACT & COUPLING NUT - BRASS, NICKEL PLATING
 CONTACT - BRASS, SILVER PLATING
 INSULATOR - PTFE, NATURAL
 RETAINING RING - BeCu OR SUS304, NATURAL
 GASKETS - SILICONE RUBBER, RED
2. ELECTRICAL:
 A. IMPEDANCE: 50 OHM
3. MECHANICAL:
 A. DURABILITY: 500 CYCLES MIN.
 B. TEMPERATURE RANGE: -65 °C TO +165 °C
4. PACKAGING:
 A. QUANTITY: SINGLE PACK
 B. MARKING: BAG TO BE MARKED
 "AMPHENOL RF, 82-202-1006, AND DATE CODE"

5 SHOWS CABLE ENTRY DIMENSIONS.

6. CABLE ASSEMBLY INSTRUCTIONS:
 A. STRIP CABLE AS SHOWN.
 B. SLIDE CLAMP NUT, WASHER, GASKET & BRAID CLAMP OVER CABLE SHEATH.
 C. COMB OUT THE BRAID AND FOLD OUT, TRIM EXCESS BRAID.
 D. SOLDER CABLE CENTER CONDUCTOR TO CENTER CONTACT.
 E. SLIDE SUB-ASSEMBLY TO THE REAR SIDE OF THE BODY AND TIGHTEN.
 MAKE SURE INTERFACE DIMENSIONS ARE MET.

THIRD ANGLE PROJ.

REVISIONS

REV	DESCRIPTION	DATE	ECO	APPR
--	RELEASE TO MFG.	--	--	--
K	REDRAWN IN PRO-E & COD ADDED	28-May-14	49890	SH

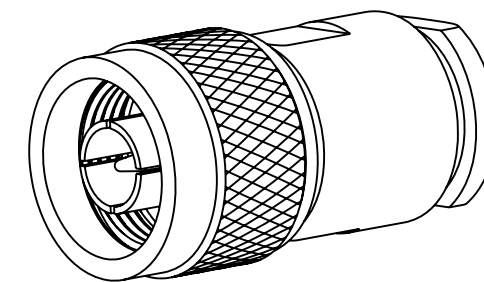

SCALE 1.500

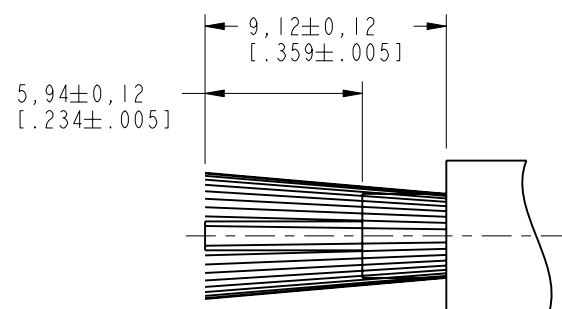

RECOMMENDED CABLE STRIPPING DIMENSIONS

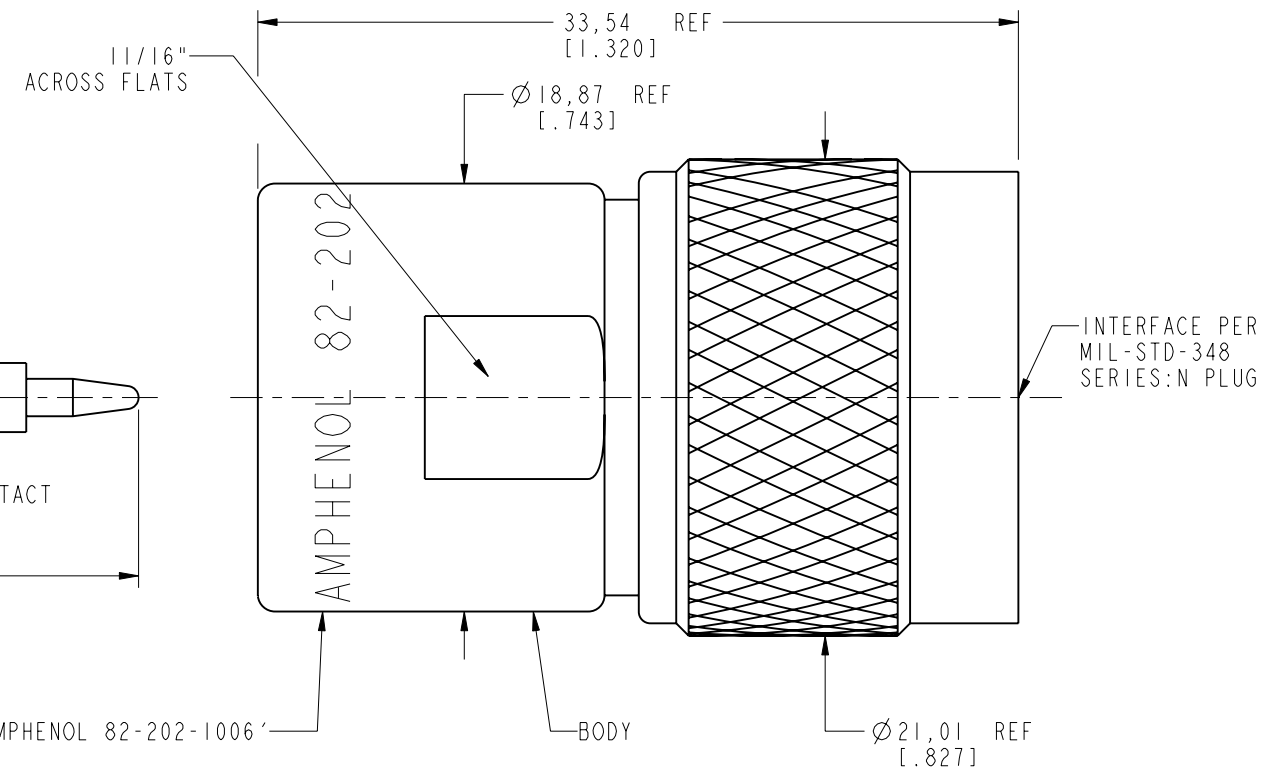
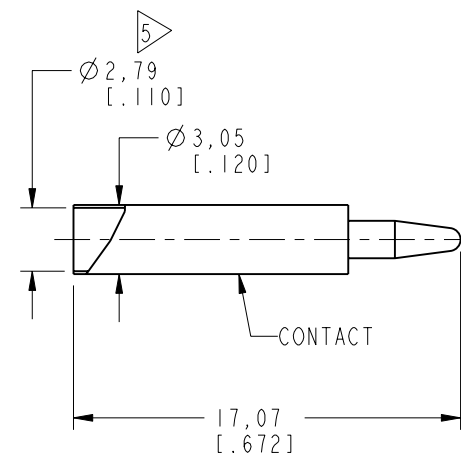
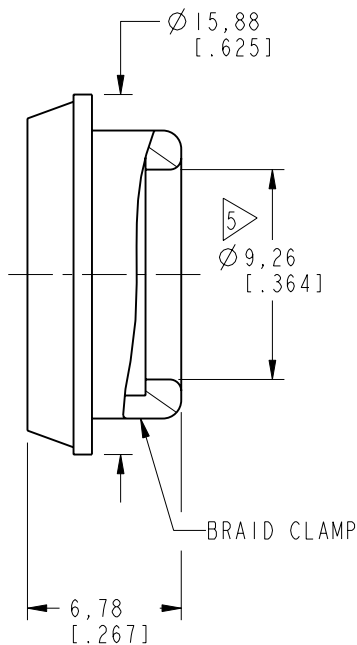
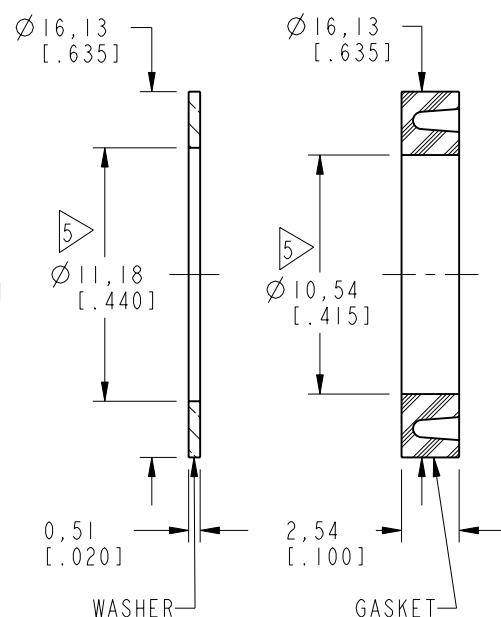
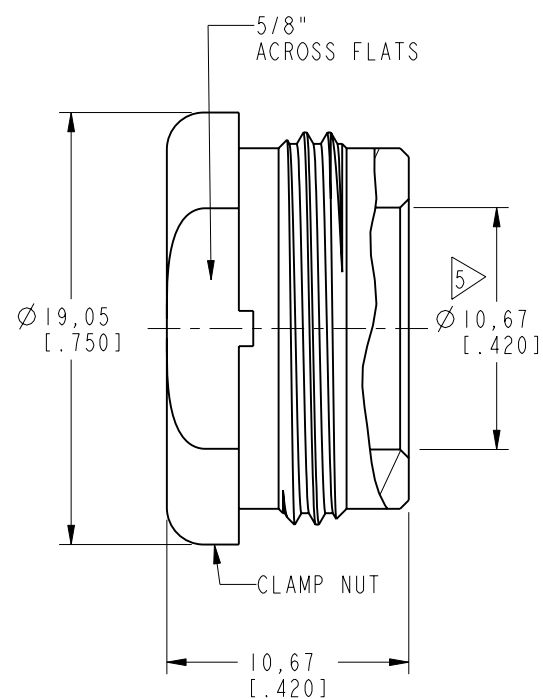

CUSTOMER OUTLINE DRAWING

ALL OTHER SHEETS ARE FOR INTERNAL USE ONLY

UNLESS OTHERWISE SPECIFIED, DIMENSIONS ARE IN INCHES AND TOLERANCES ARE: 2 PLACE DECIMAL 3 PLACE DECIMAL ANGLES ±.015 (0,381 mm) ±.005 (0,127 mm) ± 1°	MATERIAL	DRAWN	DATE	TITLE TYPE "N" PLUG FOR BELDEN # 9913 CABLE	Amphenol RF www.amphenolrf.com
	SEE NOTES	R. MAO	07-May-14		
NOTICE - These drawings, specifications, or other data (1) are, and remain the property of Amphenol corp. (2) must be returned upon request; and (3) are confidential and not to be disclosed to any person other than those to whom they are given by Amphenol Corp. the furnishing of these drawings, specifications, or other data by Amphenol Corp., or to any other person to anyone for any purpose is not to be regarded by implication or otherwise in any manner licensing, granting rights to permitting such holder or any other person to manufacture, use or sell any product, process or design, patented or otherwise, that may in any way be related to or disclosed by said drawings, specifications, or other data.	REFERENCE	ENGINEER	DATE	SCALE: 3.0:1.0 SHEET 2 OF 2	DRAWING NO. 82-202-1006
	EAR # 112-972870	K. CAPOZZI	18-Nov-13		APPROVED
	CONFIGURATION LEVEL: □□□□	FINISH	S. HSIEH	07-May-14	CAD FILE