

TECHNICAL FEATURES

Sound level 116dB(A)2mt. ±3%

CEE-ECE homologation (E3) 54512 [e3]

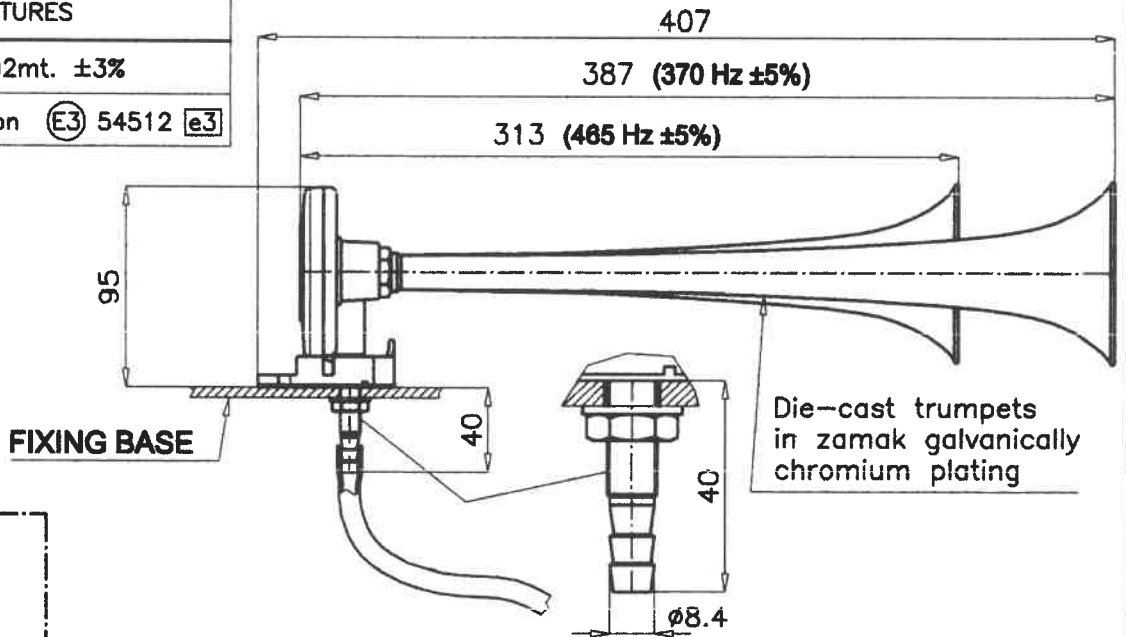

DRILLING APPLICATION

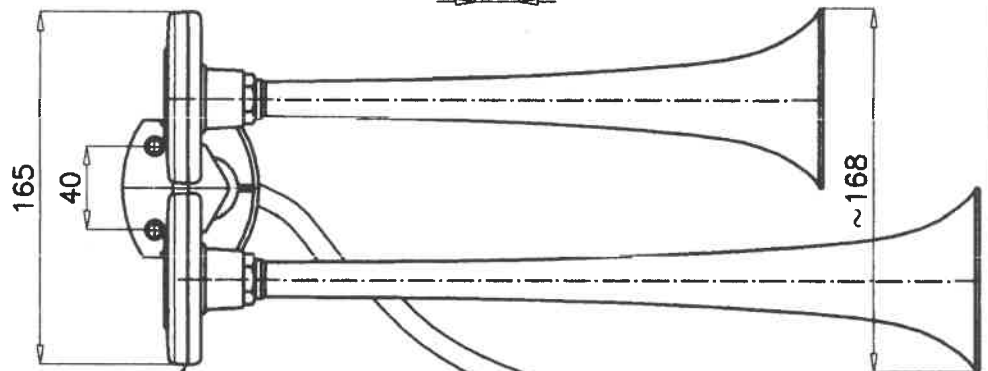
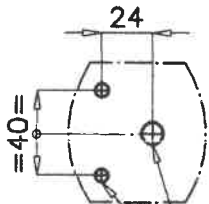

Acoustic base: chromed diecast aluminium alloy

Optional: painted die cast aluminium alloy

TECHNICAL FEATURES FOR FC1 COMPRESSOR

Tension-Volt	12.5	24.5		
Absorption- Amp.	13÷14	7÷8	±5%	Tolerance
Airflow- l/h	5500	5500	±5%	
Pressure- bar	1.3÷1.45	1.3÷1.45	±5%	

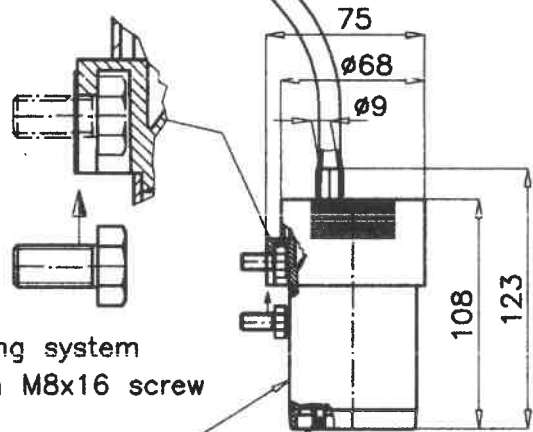

Fixing system with M8x16 screw

FC1 compressor 12V-24V

6.3x0.8mm terminals

N°	INDICE	DESCRIZIONE	DATA	DISEGNATORE
----	--------	-------------	------	-------------

MATERIALE: TOLLERANZE GENERALI SECONDO UNI-ISO 2768-m

TRATTAMENTO:

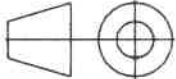
 Fabbrica Italiana Segnalatori Acustici	DIS.	Panà	FIRMA	DATA	25.03.2017	SCALA	/	
	VER.							
	DES.	Technical sheet for horn model				CODICE DIS. 10-025-03		

VULCAN FV2C
code 1010200-chromed base
1010201-painted base