

HDC insert HDC HQ 5 FC

Weidmüller Interface GmbH & Co. KG
 Klingenbergstraße 16
 D-32758 Detmold
 Germany
 Fon: +49 5231 14-0
 Fax: +49 5231 14-292083
 www.weidmueller.com



A small unit that packs a big punch. The electrical values speak for themselves. Proven HE crimp contacts can also be used here.

Number of poles: **5 (+PE)**

Rated current: **16 A**

Rated voltage: **250 V**

Rated voltage acc. to UL/CSA: **600 V AC/DC**

Crimp connection

General ordering data

Type	HDC HQ 5 FC
Order No.	1912460000
Version	HDC insert, Female, 250 V, 16 A, No. of poles: 5, Crimp connection, Size: 1
GTIN (EAN)	4032248542055
Qty.	1 pc(s).

**HDC insert
HDC HQ 5 FC**

Weidmüller Interface GmbH & Co. KG
 Klingenbergstraße 16
 D-32758 Detmold
 Germany
 Fon: +49 5231 14-0
 Fax: +49 5231 14-292083
 www.weidmueller.com

Technical data**Dimensions and weights**

Width	21 mm	Width (inches)	0.827 inch
Height	40.1 mm	Height (inches)	1.579 inch
Depth	21 mm	Depth (inches)	0.827 inch
Net weight	15 g		

Temperatures

Limit temperature	-40 °C ... 125 °C
-------------------	-------------------

Environmental Product Compliance

REACH SVHC	Lead 7439-92-1
------------	----------------

Dimensions

Height of socket	40.1 mm	Total length base	21 mm
------------------	---------	-------------------	-------

General data

Insulating material	PC glass-fibre reinforced (UL-listed and railway-certified)	Insulating material group	IIIa
Insulation strength	$10^{10} \Omega$	Material	Copper alloy
No. of poles	5	Plugging cycles, gold	≥ 500
Plugging cycles, silver	≥ 500	Pollution severity	3
Rated current (DIN EN 61984)	16 A	Rated impulse voltage (DIN EN 61984)	6 kV
Rated voltage (DIN EN 61984)	250 V	Rated voltage according to UL/CSA	600 V AC/DC
Series	HQ	Size	1
Surface finish	Silver passivated, gold	Type	Female
UL 94 flammability rating	V-0	Volume resistance	$\leq 2m\Omega$

Connection data PE

Blade size, slotted (PE connection)	SD 0.6 x 3.5	Connection type PE	Screw connection
Fixing screw	M 3	Rated cross-section	2.5 mm ²
Stripping length PE connection	10 mm	Tightening torque, max. PE connection	0.55 Nm
Tightening torque, min. PE connection	0.5 Nm	Wire connection cross section, finely stranded, max.	2.5 mm ²
Wire connection cross-section, finely stranded with wire-end ferrules DIN 46228/4, max.	2.5 mm ²	Wire connection cross-section, finely stranded with wire-end ferrules DIN 46228/4, min.	0.5 mm ²
Wire connection cross-section, finely stranded, min.	0.5 mm ²	Wire cross section, AWG (PE), max.	AWG 14
Wire cross section, AWG (PE), min.	AWG 20		

**HDC insert
HDC HQ 5 FC**

Weidmüller Interface GmbH & Co. KG
 Klingenbergstraße 16
 D-32758 Detmold
 Germany
 Fon: +49 5231 14-0
 Fax: +49 5231 14-292083
 www.weidmueller.com

Technical data**Version**

Conductor cross-section, max.	4 mm ²	Conductor cross-section, min.	0.5 mm ²
Material	Copper alloy	Size	1
Stripping length, rated connection	7.5 mm	Surface finish	Silver passivated, gold
Type of connection	Crimp connection	Volume resistance	≤ 2mΩ
Wire connection cross section AWG, max.	AWG 12	Wire connection cross section AWG, min.	AWG 20
Wire connection cross section, finely stranded, max.	2.5 mm ²	Wire connection cross-section, finely stranded with wire-end ferrules DIN 46228/4, max.	2.5 mm ²
Wire connection cross-section, finely stranded with wire-end ferrules DIN 46228/4, min.	0.5 mm ²	Wire connection cross-section, finely stranded, min.	0.5 mm ²

Classifications

ETIM 3.0	EC001121	ETIM 4.0	EC000438
ETIM 5.0	EC000438	ETIM 6.0	EC000438
UNSPSC	30-21-18-01	eClass 5.1	27-14-34-19
eClass 6.2	27-26-12-04	eClass 7.1	27-44-02-05
eClass 8.1	27-44-02-05	eClass 9.0	27-44-02-05
eClass 9.1	27-44-02-05		

Approvals

Approvals



ROHS

Conform

Downloads

Brochure/Catalogue	CAT 3 HDC 17/18 EN FL FIELDWIRING EN
Engineering Data	EPLAN, WSCAD, Zuken E3.S
Engineering Data	STEP

**HDC insert
HDC HQ 5 FC**

Weidmüller Interface GmbH & Co. KG
Klingenbergstraße 16
D-32758 Detmold
Germany
Fon: +49 5231 14-0
Fax: +49 5231 14-292083
www.weidmueller.com

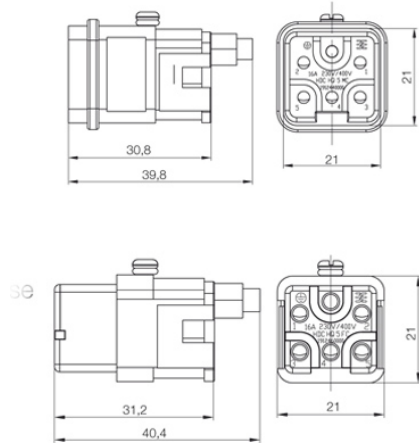
Drawings

Tightening torques and screwing tools

Screw size	Connector type	Dia. tightening torque in Nm	Recommended blade inserts and AF size for hexagon socket
M 2.5	Signal contacts		
	S 6/6	0.5 - 0.55	SD 0.6 x 3.5 mm or PZ0
	S 6/12	0.5 - 0.55	SD 0.6 x 3.5 mm or PZ0
M 2.9 x 0.5	Fastening screws		
	HQ 4/2	0.8 (plastic) / 1.1 (metal)	SD 0.6 x 3.5 mm or PH0
	HQ 8	0.8 (plastic) / 1.1 (metal)	SD 0.6 x 3.5 mm or PH0
	HQ 17	0.8 (plastic) / 1.1 (metal)	SD 0.6 x 3.5 mm or PH0
M 3	Contact screws		
	HA 3	0.5 - 0.55	SD 0.5 x 3.0 mm
	HA 4	0.5 - 0.55	SD 0.5 x 3.0 mm
	HA 10 bis HA 48	0.5 - 0.55	SD 0.6 x 3.5 mm or PH0
	HE	0.5 - 0.55	SD 0.6 x 3.5 mm or PZ0
	HVE	0.5 - 0.55	SD 0.6 x 3.5 mm or PZ0
	Signal contacts:		
	S 4/2	0.5 - 0.55	SD 0.6 x 3.5 mm or PZ0
	S 4/8	0.5 - 0.55	SD 0.6 x 3.5 mm or PZ0
	PE connection via female contact		
	S 4	0.5 - 0.8	SD 0.6 x 3.5 mm
	ConCept modular frame, metal	0.5 - 0.55	SD 0.6 x 3.5 mm
	PE terminal		
	HQ 5	0.5 - 0.55	SD 0.6 x 3.5 or 0.8 x 4 mm
	HQ 7	0.5 - 0.55	SD 0.6 x 3.5 or 0.8 x 4 mm
	Fastening screws	0.5 - 0.55	SD 0.6 x 3.5 mm or PZ0
	Guide pin	0.5 - 0.55	SD 0.6 x 3.5 mm or PZ0
	Guide bush	0.5 - 0.55	SD 0.6 x 3.5 mm or PZ0
	Coding pins	0.5 - 0.55	SD 0.6 x 3.5 mm or PZ0
	M 4	Contact screws	
HSB		1.2 - 1.5	SD 0.6 x 3.5 or 0.8 x 4 mm or PZ1
PE connection via male contact			
S 4		0.5 - 0.8	SD 0.6 x 3.5 mm
ConCept modular frame, metal		1.2 - 1.5	SD 0.6 x 3.5 mm
PE terminal			
HA		1.2 - 1.5	SD 0.6 x 3.5 or 0.8 x 4 mm or PH1
HE		1.2 - 1.5	SD 0.6 x 3.5 or 0.8 x 4 mm or PH1
HEE		1.2 - 1.5	SD 0.6 x 3.5 or 0.8 x 4 mm or PH1
HVE		1.2 - 1.5	SD 0.6 x 3.5 or 0.8 x 4 mm or PH1
HD		1.2 - 1.5	SD 0.6 x 3.5 or 0.8 x 4 mm or PZ1
HDD		1.2 - 1.5	SD 0.6 x 3.5 or 0.8 x 4 mm or PZ1
S 6/6 (for signal contacts)		1.2 - 1.5	0.8 x 4 mm or PZ1
ConCept modular frame, plastic		1.2 - 1.5	0.8 x 4 mm or PZ1
M 5		PE terminal	
	HSB	2 - 2.5	SD 1 x 5.5 mm or PZ2
	S 4/0 (Screw connection)	2 - 2.5	SD 1.2 x 6.5 mm or PH2
	S 4/0 (Axial screw connection)	2 - 2.5	SD 0.8 x 4 mm or PZ 2
	S 4/2	2 - 2.5	SD 1.2 x 6.5 mm or PH2
	S 4/8	2 - 2.5	SD 1.2 x 6.5 mm or PH2
	S 6/12	2 - 2.5	SD 0.8 x 4 mm or PZ 2
	S 6/36	2 - 2.5	SD 1.2 x 6.5 mm or PH2
	S 8/24	2 - 2.5	SD 1.2 x 6.5 mm or PH2
	S 12/2	2 - 2.5	SD 1.2 x 6.5 mm or PH2
	M 6	Power contacts	
S 4/0 (Screw connection)		1.2 (1.5 mm ²) / 2 (2.5 mm ²) / 3 (4-16 mm ²)	SD 0.8 x 4 mm
S 4/2		1.2 (1.5 mm ²) / 2 (2.5 mm ²) / 3 (4-16 mm ²)	SD 0.8 x 4 mm
S 4/8		1.2 (1.5 mm ²) / 2 (2.5 mm ²) / 3 (4-16 mm ²)	SD 0.8 x 4 mm
M 7 x 0.75	Power contacts		
	S 4	1.1 - 1.7	SW 2
	S 6/6 (+ PE)	6 - 8	SW 4
M 8 x 0.75	Power contacts		
	S 6/12	1.1 - 1.7	SW 2
	S 8/0 (+ PE)	6 (10-16 mm ²) - 7 (25 mm ²)	SW 4
M10 x 1	Power contacts		
	S 4/0 (Axial connection)	2 - 3	SW 3

Increasing the tightening torque does not improve the contact resistance. The stated torque settings offer optimal mechanical, thermal and electrical conditions. Exceeding the recommended values may even damage the conductor and terminal.