



Model number

VAN-115/230AC-K27

AS-Interface power supply, data decoupling, 4 A

Features

- Up to 4 A output load
- LED operating display
- 100 V AC up to 240 V AC
- AS-Interface filter integrated
- Earth fault detection

Dimensions

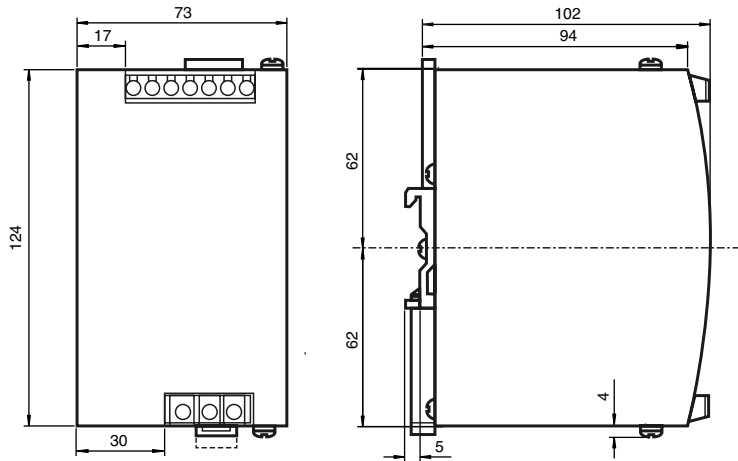

Electrical connection

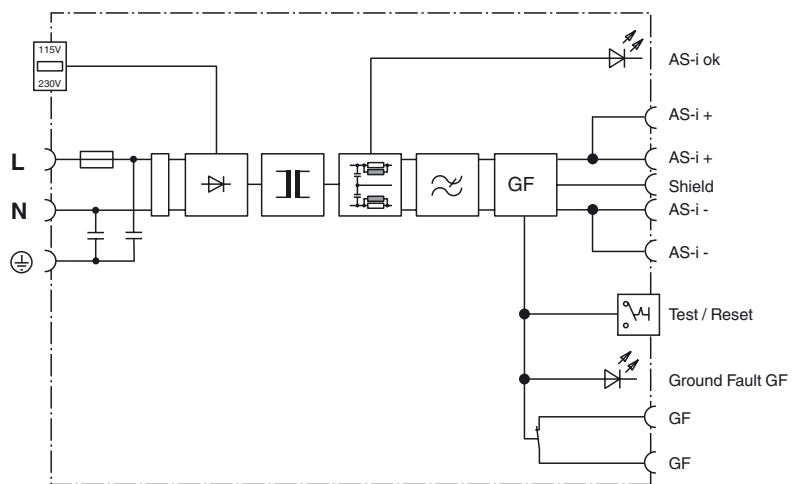

Indicating / Operating means

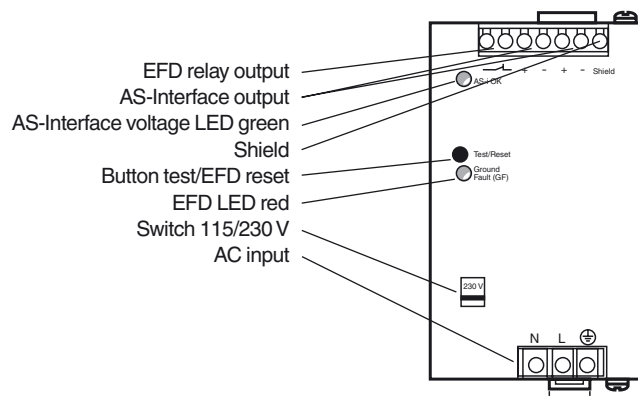

Release date: 2014-12-11 10:52 Date of issue: 2014-12-11 238626_eng.xml

Refer to "General Notes Relating to Pepperl+Fuchs Product Information".

Pepperl+Fuchs Group
www.pepperl-fuchs.com

USA: +1 330 486 0001
fa-info@us.pepperl-fuchs.com

Germany: +49 621 776 4411
fa-info@de.pepperl-fuchs.com

Singapore: +65 6779 9091
fa-info@sg.pepperl-fuchs.com

Technical data**General specifications**

UL File Number	E223176
----------------	---------

Indicators/operating means

Reset push-button switch	earth fault simulation/reset of earth fault display
LED EFD	earth fault display; LED red
LED AS-i ok	LED green: ON: AS-Interface voltage OK OFF: overload or no supply voltage

Electrical specifications

Fusing	T3A 15/250 V HBC (not accessible)
Rated operating voltage	U_e 85 ... 132 V _{AC} 184 ... 264 V _{AC} 240 ... 300 V _{DC}
Rated operating current	I_e 2.7 A at 115 V _{AC} 1.3 A at 230 V _{AC}
Supply frequency	47 ... 63 Hz (alternatively, DC possible)
Efficiency	typ. 90 % (230 V _{AC} , 4 A)
Electrical isolation	SELV/PELV
Peak inrush current	I^2t < 3.7 A ² s (120 V _{AC}) < 4.6 A ² s (132 V _{AC}) < 2.5 A ² s (230 V _{AC}) < 3.3 A ² s (264 V _{AC})

Output

Short-circuit protection/overload	> 4.2 A < 6.5 A
Current limit	starts at > 4.2 A
Current	4 A
Voltage	30.5 V _{DC} ±3 % fixed
Residual ripple	< 50 mV _{SS} (500 kHz bandwidth, 50 Ω measurement, with resistive load)
Overvoltage protected	limited to max. 55 V

Ambient conditions

Ambient temperature	-10 ... 70 °C (14 ... 158 °F) Note derating
Storage temperature	-25 ... 85 °C (-13 ... 185 °F)
Shock and impact resistance	15g/6 ms 10g/11 ms
Vibration resistance	Sine 2 – 17.8 Hz: ± 1.6 mm Sine 17.8 ... 500 Hz: 2 g Random 2 ... 500 Hz: 0.5 m ² (s ³)
Pollution Degree	2

Mechanical specifications

Degree of protection	IP20
Protection class	1 (IEC 60536); Protective conductor connection necessary
Connection	Connection terminals, max. conductor cross-section Flexible cable: 0.5 ... 4 mm ² Rigid cable: 0.5 ... 6 mm ² Stripping length 7 mm
Mass	650 g
Mounting	DIN mounting rail

Compliance with standards and directives

Directive conformity	
EMC Directive 2004/108/EC	EN 55022:2006, EN 55011:2009 Class B EN 61000-6-3:2001, EN 61204-3:2001
Standard conformity	
Noise immunity	EN 61000-6-2:2005
Emitted interference	EN 61000-6-3:2007 EN 61000-3-2:2010 EN 61000-3-3:2009
Electrical isolation	IEC 60364-4-41:2005 (PELV) IEC 60950:1999 (SELV)
Degree of protection	IEC 60529:2001
Pollution Degree	EN 50178:1997
Mech. capacity	EN 60068-2-6:2008 (Sinus) EN 60068-2-64:2009 (Random)
Shock and impact resistance	EN 60068-2-27:1995

Notes

In an AS-Interface network only one device can be operated earth fault detection. If there are many devices in an AS-Interface network, this can lead to the earth fault monitoring response threshold becoming less sensitive.

Function

The primary switched-mode power supply was designed for fieldbus applications that transfer energy and data together via a two-wire cable (AS-Interface concept). It supplies a fully extended AS-Interface system with a maximum output current of 4.0 A. Due to the sinusoidal current consumption of the network, harmonics are avoided.

The power supply assumes the function of supplying power, data decoupling for the power source and balancing both output lines (AS-Interface+ and AS-Interface-) with respect to the machine ground (shielded connection). The transformer allows the use of unshielded load cables. The power supply is protected by an internal fuse that eliminates the need for additional device protection measures.

Ground fault monitor GF:

The switch output of the ground fault monitor evaluates any short circuits detected in the AS-Interface system. With the potential-free transistor output, the system can be shut down using the control program. The output is normally closed, but opens when a ground fault is detected. The "GF" LED also signals the presence of a ground fault. This output will close when the power supply is restarted or the reset button is pressed for (> 2 seconds). It is essential to connect the shield to PE or the machine ground to guarantee proper operation.

Checking the ground fault monitor:

Pressing the reset button briefly (< 2 seconds) simulates a ground fault in the device. Detection, evaluation and signaling of a ground fault and the switch output can be tested at suitable intervals. A ground fault generated in this way can be reset by pressing the reset button for (> 2 seconds).

Derating

Output current

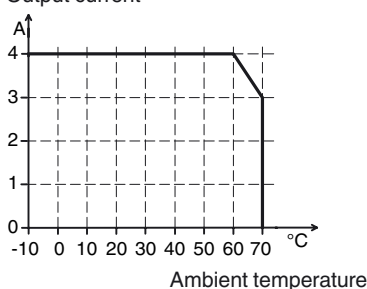
**Accessories****AS-Interface Power Calculator**

AS-Interface Power supply and network checking utility