

Indexing Plungers 817

Material Steel Version: Steel, black oxide finish. Plunger pin: Hardened.
Material Stainless Steel Version: Stainless steel 1.4305 (AISI 303).
 Plunger pin nickel-plated. Knob: Plastic Thermoplast (polyamide) black, matt finish, cannot be disassembled.

Indexing plunger 817 offer the following advantages:

- small outer dimensions.
- most of the release mechanism (version C/CK) is covered.
- defined thread length by an undercut at the end of the thread (version G/GK).

Version B/BK with knob, without notched catch, this version is used where, on releasing the knob, the plunger pin should be returned to its initial position by the spring force.

Version C/CK with knob, is used if the plunger pin has to remain in retracted position. To achieve this, the knob is rotated by 90 degrees after being retracted. A notched catch stops the locked-in knob from returning to its initial position accidentally or due to vibration.

Version G/GK with threaded plunger end, for applications where a special knob to customer's request is required or where the plunger pin is not shifted manually.

STAINLESS

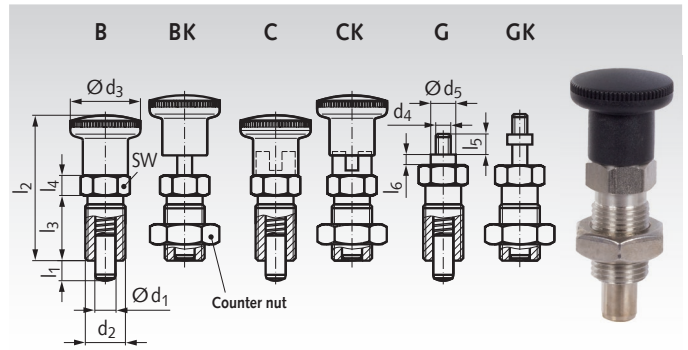

Version B: with knob, without counter nut.
 Version BK: with knob, with counter nut.

Version G: with threaded bolt, without counter nut.
 Version GK: with threaded bolt, with counter nut.

Version C: with indexing knob, without counter nut.

Version CK: with indexing knob, with counter nut.

Product No. Steel	Product No. Stainless Steel	Version	-0,02/-0,04		d ₂ mm	d ₃ mm	d ₄ mm	d ₅ mm	l ₂ mm	l ₃ mm	l ₄ mm	l ₅ mm	l ₆ mm	SW mm	Spring Load*		Weight g
			d ₁ mm	l ₁ mm											Initial N	End N	
666 684 00	666 996 84	B	4	4	M8x1	16	-	-	35	16	5	-	-	10	4,0	12,0	11,0
666 685 00	666 996 85	B	5	5	M10x1	19	-	-	40	18	6	-	-	12	5,0	15,0	18,0
666 686 00	666 996 86	B	6	6	M12x1,5	23	-	-	48	22	6	-	-	14	6,0	19,0	29,0
666 687 00	666 996 87	B	8	8	M16x1,5	28	-	-	58	26	8	-	-	17	8,5	26,0	63,0
666 690 00	666 996 90	B	10	12	M16x1,5	28	-	-	58	26	8	-	-	17	9,5	38,0	64,0
666 694 00	666 996 94	BK	4	4	M8x1	16	-	-	35	16	5	-	-	10	4,0	12,0	13,8
666 695 00	666 996 95	BK	5	5	M10x1	19	-	-	40	18	6	-	-	12	5,0	15,0	25,0
666 696 00	666 996 96	BK	6	6	M12x1,5	23	-	-	48	22	6	-	-	14	6,0	19,0	39,0
666 698 00	666 996 98	BK	8	8	M16x1,5	28	-	-	58	26	8	-	-	17	8,5	26,0	83,0
666 700 00	666 997 00	BK	10	12	M16x1,5	28	-	-	58	26	8	-	-	17	9,5	38,0	79,8
666 704 00	666 997 04	C	4	4	M8x1	16	-	-	35	16	5	-	-	10	4,0	12,0	13,0
666 705 00	666 997 05	C	5	5	M10x1	19	-	-	40	18	6	-	-	12	5,0	15,0	21,0
666 706 00	666 997 06	C	6	6	M12x1,5	23	-	-	48	22	6	-	-	14	6,0	19,0	33,0
666 708 00	666 997 08	C	8	8	M16x1,5	28	-	-	58	26	8	-	-	17	8,5	26,0	66,5
666 710 00	666 997 10	C	10	12	M16x1,5	28	-	-	58	26	8	-	-	17	9,5	38,0	69,6
666 714 00	666 997 14	CK	4	4	M8x1	16	-	-	35	16	5	-	-	10	4,0	12,0	15,8
666 715 00	666 997 15	CK	5	5	M10x1	19	-	-	40	18	6	-	-	12	5,0	15,0	28,0
666 716 00	666 997 16	CK	6	6	M12x1,5	23	-	-	48	22	6	-	-	14	6,0	19,0	43,0
666 718 00	666 997 18	CK	8	8	M16x1,5	28	-	-	58	26	8	-	-	17	8,5	26,0	86,5
666 720 00	666 997 20	CK	10	12	M16x1,5	28	-	-	58	26	8	-	-	17	9,5	38,0	85,0
666 734 00	666 997 34	G	4	4	M8x1	-	M3	7	-	16	5	4,5	2,5	10	4,0	12,0	9,8
666 735 00	666 997 35	G	5	5	M10x1	-	M4	8	-	18	6	5,5	3,0	12	5,0	15,0	15,8
666 736 00	666 997 36	G	6	6	M12x1,5	-	M5	9	-	22	6	7,0	3,5	14	6,0	19,0	25,3
666 738 00	666 997 38	G	8	8	M16x1,5	-	M6	10	-	26	8	8,5	4,0	17	8,5	26,0	53,9
666 740 00	666 997 40	G	10	12	M16x1,5	-	M6	10	-	26	8	8,5	4,0	17	9,5	38,0	55,6
666 744 00	666 997 44	GK	4	4	M8x1	-	M3	7	-	16	5	4,5	2,5	10	4,0	12,0	12,7
666 745 00	666 997 45	GK	5	5	M10x1	-	M4	8	-	18	6	5,5	3,0	12	5,0	15,0	22,8
666 746 00	666 997 46	GK	6	6	M12x1,5	-	M5	9	-	22	6	7,0	3,5	14	6,0	19,0	35,3
666 748 00	666 997 48	GK	8	8	M16x1,5	-	M6	10	-	26	8	8,5	4,0	17	8,5	26,0	73,9
666 750 00	666 997 50	GK	10	12	M16x1,5	-	M6	10	-	26	8	8,5	4,0	17	9,5	38,0	75,6

* Statistical average.

Steel Versions:



Stainless Steel Versions:

